



OPEN

Compute Project

Open Rack V3 48V Rectifier (PSU)

Rev: 0.82

10/07/2020

Authors:

Contributions to this Specification are made under the terms and conditions set forth in **Open Compute Project Contribution License Agreement (“OCP CLA”) (“Contribution License”)** by:

[Contributor Name(s) or Company name(s)]

You can review the signed copies of the applicable Contributor License(s) for this Specification on the OCP website at <http://www.opencompute.org/products/specsanddesign>

Usage of this Specification is governed by the terms and conditions set forth in **[select one: Open Web Foundation Final Specification Agreement (“OWFa 1.0”), Open Compute Project Hardware License – Permissive (“OCPHL Permissive”), Open Compute Project Hardware License – Copyleft (“OCPHL Reciprocal”)] (“Specification License”)**.

You can review the applicable Specification License(s) executed by the above referenced contributors to this Specification on the OCP website at <http://www.opencompute.org/participate/legal-documents/>

Note: The following clarifications, which distinguish technology licensed in the Contribution License and/or Specification License from those technologies merely referenced (but not licensed), were accepted by the Incubation Committee of the OCP:

[insert “None” or a description of the applicable clarifications].

NOTWITHSTANDING THE FOREGOING LICENSES, THIS SPECIFICATION IS PROVIDED BY OCP "AS IS" AND OCP EXPRESSLY DISCLAIMS ANY WARRANTIES (EXPRESS, IMPLIED, OR OTHERWISE), INCLUDING IMPLIED WARRANTIES OF MERCHANTABILITY, NON-INFRINGEMENT, FITNESS FOR A PARTICULAR PURPOSE, OR TITLE, RELATED TO THE SPECIFICATION. NOTICE IS HEREBY GIVEN, THAT OTHER RIGHTS NOT GRANTED AS SET FORTH ABOVE, INCLUDING WITHOUT LIMITATION, RIGHTS OF THIRD PARTIES WHO DID NOT EXECUTE THE ABOVE LICENSES, MAY BE IMPLICATED BY THE IMPLEMENTATION OF OR COMPLIANCE WITH THIS SPECIFICATION. OCP IS NOT RESPONSIBLE FOR IDENTIFYING RIGHTS FOR WHICH A LICENSE MAY BE REQUIRED IN ORDER TO IMPLEMENT THIS SPECIFICATION. THE ENTIRE RISK AS TO IMPLEMENTING OR OTHERWISE USING THE SPECIFICATION IS ASSUMED BY YOU. IN NO EVENT WILL OCP BE LIABLE TO YOU FOR ANY MONETARY DAMAGES WITH RESPECT TO ANY CLAIMS RELATED TO, OR ARISING OUT OF YOUR USE OF THIS SPECIFICATION, INCLUDING BUT NOT LIMITED TO ANY LIABILITY FOR LOST PROFITS OR ANY CONSEQUENTIAL, INCIDENTAL, INDIRECT, SPECIAL OR PUNITIVE DAMAGES OF ANY CHARACTER FROM ANY CAUSES OF ACTION OF ANY KIND WITH RESPECT TO THIS SPECIFICATION, WHETHER BASED ON BREACH OF CONTRACT, TORT (INCLUDING NEGLIGENCE), OR OTHERWISE, AND EVEN IF OCP HAS BEEN ADVISED OF THE POSSIBILITY OF SUCH DAMAGE.

Table of Contents

License (OCP CLA Option)	2
Table of Contents	3
Revision History	5
1. Scope	7
2. Overview	7
3. Electrical Requirements	7
3.1 AC Input Voltage & Frequency	8
3.2 Start-up Sequence	8
3.3 Start - up / Turn on Time - Cold Start	8
3.4 Start - up / Turn on Time - AC Failure / Recovery	8
3.5 Input Over Voltage and Under Voltage Protection	8
3.6 Input Over-Current Protection	9
3.7 AC Inrush Current	9
3.8 Efficiency	9
3.9 Power Factor	10
3.10 Total Harmonic Current Distortion (THD)	10
3.11 DC Output voltage	10
3.12 DC Output set point voltage accuracy	10
3.13 DC Output droop voltage	10
3.14 DC Output Voltage Ripple & Noise	10
3.15 Dynamic Response	11
3.16 Overshoot at Turn on / Turn off	11
3.17 Hold - up Time	11
3.18 Output Over Voltage Protection (OVP)	11
3.19 Constant current operation	11
3.20 Output Short-circuit Protection	11
3.21 Over Temperature Protection	12
3.22 Active Current Sharing Accuracy through analog bus.	12
3.23 Rectifier physical addressing	12
3.24 48V/50V output voltage selection	12
3.25 LED	12
3.26 Grounding	13
3.27 Start-up Timing and synchronization Requirements	13
3.28 Surge power capability requirements	14

3.29	Power system stability requirements	15
3.30	PSU connector pinout	15
4.	Communication	17
4.1	Firmware Upgrade	19
4.2	Metering Accuracy	19
4.3	Last Power Failure Fault Conditions	20
4.4	Rectifier Failure	20
4.5	Identification	20
4.6	Position	20
4.7	Blackbox Function	20
4.7.1	Fault Log History	21
5.	Environment	22
5.1	Temperature	22
5.2	Humidity	22
5.3	Altitude	22
5.4	Acoustic Noise	22
5.5	Vibration	23
5.5.1	Operational	23
5.5.2	Non-Operational	23
5.6	Shock	23
5.6.1	Operational	23
5.6.2	Non-Operational	23
6.	Thermal	23
6.1	Operational	23
6.2	Thermal design requirements	24
6.3	Fan Failure	24
6.4	Rectifier Thermal Monitoring	25
7.	Mechanical	25
7.1	Physical Dimensions	25
7.2	Indicators	25
7.4	Chassis Interface	26
7.5	Rear Blind mate connector	26
8.	Reliability and Quality	27
8.1	Derating Design	27
8.2	Reliability Prediction	27
8.3	Design Failure Mode and Effect Analysis (DFMEA)	27
8.4	High Accelerated Life Test (HALT)	27
8.5	Burn-In (BI) and Ongoing Reliability Testing (ORT)	28

Open Compute Project • Open Rack V3 Power Shelf	
8.6 Manufacturing Quality	28
9. Compliance requirements	28
9.1 Safety Standards	28
9.1.1 Component Safety requirements	29
9.2 EMC Requirements	29
9.3 Environmental Compliance	30
9.4 Documentation	30
Attachment A: Power Supply Impedance Specification	31
Attachment B: PSU PMBUS Software Interface Specification	31
Attachment C: ModBus Software Interface Specification and register map	31

Revision History

Date	Version	Change By	Comments
08/24/2020	0.5	hamidk@	<p>Added power system stability requirements on section 3.29 and appendix A.</p> <p>Added PMBus Spec, Appendix B.</p> <p>Added Modbus Spec, Appendix C.</p> <p>Added surge power requirements on Sec 3.28</p> <p>Added power derating vs input voltage on section 3.1.</p> <p>Update fuse IR as 14kA on section 3.6.</p> <p>Updated section 3.12, 3.13, 3.15, 3.19, 3.20, 3.23, 3.27</p> <p>Removed section 4.2 Output Voltage / Current Control</p> <p>Updated comms spec to support ModBus as well.</p> <p>Added section 3.30 PSU connector pinout.</p>
8/26/2020	0.6	hamidk@	<p>Updated Reset_H signal function on section 3.30.</p> <p>Updated inrush current as 30A on sec 3.7.</p> <p>Updated min PF as 0.95 on sec 3.9.</p> <p>Updated current sharing accuracy to be +/- 2% or better under load > 50% and +/- 5% or better under load >20%, sec 3.23.</p> <p>Added sec 4.2 Metering Accuracy.</p> <p>Added sec 4.7 Blackbox Function</p> <p>Added sec 3.29 Timing Requirements</p> <p>Added PLS (power loss siren) on sec 3.31</p>
09/09/2020	0.7	hamidk@	<p>Updated 3.27 Start-up Timing and synchronization Requirements</p>

Open Compute Project • Open Rack V3 Power Shelf

			Added block diagrams on sec 4 Updated sec 3.12 and 3.15, 3.23, 3.24, 3.25, 3.26, 9.1.1 Moved appendixes to attachments.
09/17/2020	0.75	hamidk@	Sec 3.27: 44V for 0.1 sec Sec 3.30: updated pinout Sec 4: added comms speed requirement and diagram.
9/21/2020	0.8	tjin@	Sec 7: Updated indicators and chassis interface.
10/05/2020	0.81	hamidk@	Added facility i-t curve sec 3.6 Added rs485_addr2 on sec 3.30 (U1)
10/07/2020	0.82	hamidk@	Section 3.30: modified IShare to single ended. Added comments for internal pull-up and pull-down resistors for input signals.

1. Scope

This document defines the technical specifications for Open Rack V3 rectifier used in the Open Compute Project.

2. Overview

This spec will define the single phase 48V power rectifiers that fits into the 48V power shelf. The rectifier is intended for use in a power shelf that is part of the rack, for supplying DC power to system loads. Several rectifiers with minimum of N+1 redundancy shall be included in the power shelf.

The rectifier operates based of “narrow-range 48V Architecture.” Based on this concept, rectifier output voltage is fixed at 50V and the regulated battery voltage is 48V. Benefits of this architecture compared to ORv2 with 40~60V dc voltage range are:

- Voltage range as low as possible to eliminate oversized voltage/current design
- Widely enable 4:1 fixed ratio converters and downstream conventional 12V PoL converters.
- Power to flow naturally, not with Software control and dependency.
- Enable simple fixed-voltage rectifier design.

3. Electrical Requirements

Requirements Brief Summary is given below:

- 3kW output power.
- Input rated voltage 200V to 277Vac with +/- 10%
- Output voltage 50V fixed on normal operation
- Peak efficiency > 97.5%, measured with fans
- Active power factor correction (meets EN/IEC 61000-3-2 and EN 60555-2 requirements)
- DC Output overvoltage and overcurrent protection
- AC Input overvoltage and undervoltage protection
- Over-temperature warning and protection
- Active current sharing on top of droop
- Hot insertion/removal (hot plug)
- Front to back air cooling
- Internally controlled variable-speed fan
- Ability to field FW upgrade (with bootloader)
- All field replaceable components shall be Tool-less front side removal

3.1 AC Input Voltage & Frequency

The rectifier shall be capable of supplying full rated output power over single phase input voltage range of 180 – 305V, and frequency of 47 – 63 Hz. Table 1 specifies the AC input voltage and frequency requirements for continuous operation.

Parameter	Typical	Min	Max	Power rating (W)
AC Input Voltage	208, 230, 240Vac or 277Vac	180Vac	305Vac	Nominal Power
Frequency	60Hz	47Hz	63Hz	Nominal Power

Table 1 : AC Input Voltage & Frequency Requirements

Table above specifies the AC input voltage and frequency requirements for continuous operation. The output power shall be derated linearly below 180VAC: 1.5kW at 100V and can shut off at 85V.

In addition, rectifier shall meet ITIC compliant requirements as below:

- 140V for 500mS
- 160V for 10S
- 0V for 20mS

Shall the ITIC curve be violated, the PSU will continue to regulate the output voltage until bulk energy is depleted. Power limitation mechanism can be activated during this time in order to survive the brown out.

3.2 Start-up Sequence

The rectifier shall be able to start up under rated nominal power at the min AC input voltage (180 VAC) as specified in Table 1 above. With AC present, within specified parameters, the rectifier must always remain operational. The startup sequence shall be designed such that the rectifiers are able to meet the overall system start-up time and inrush current requirements specified below. The max capacitive loading on a single unit at power up is 10 mF.

After AC voltage is applied, the internal bias supply starts, the microcontroller boots and keeps the PFC off as well as the dc-dc converter. Then the microcontroller closes the inrush relay and turns on all the converters

3.3 Start - up / Turn on Time - Cold Start

The output voltage of the rectifier shall be monotonic during turn on and turn off, there shall not have any reverse voltage during turn off.

3.4 Start - up / Turn on Time - AC Failure / Recovery

The rectifier shall recover automatically after an AC power failure. The start-up time requirement shall be same as that of a cold start specified in section above.

3.5 Input Over Voltage and Under Voltage Protection

The maximum ac input voltage will never be above 345V for one ac cycle. The rectifier shall contain protection circuitry such that application of an input voltage below the minimum specified in Table1 shall not cause any damage to the rectifier. The rectifier shall shut down if the input voltage is over the maximum input voltage.

3.6 Input Over-Current Protection

The rectifier shall incorporate primary fusing on *both phase and return lines* for input over-current protection to meet product safety requirements. Fuses shall be selected to prevent nuisance trips. Fuse may be internal to unit and need not be user serviceable. AC inrush current shall not cause the fuse to blow under any conditions. No rectifier operating condition shall cause the fuse to blow unless a component in the rectifier has failed. This includes DC output overload and short-circuit conditions. Fuse shall be approved by UL for an interrupt rating of at least 14kA for 10mS.

PSU fuse shall be in coordination with Datacenter Tapbox breaker curve as given below. NEC breakers are 20 and 30A (two ac feeds go to the power shelf – one PSU per input ac phase feed). IEC breaker is normally 32A (one ac feed goes to the power shelf – two PSUs per input ac phase feed).

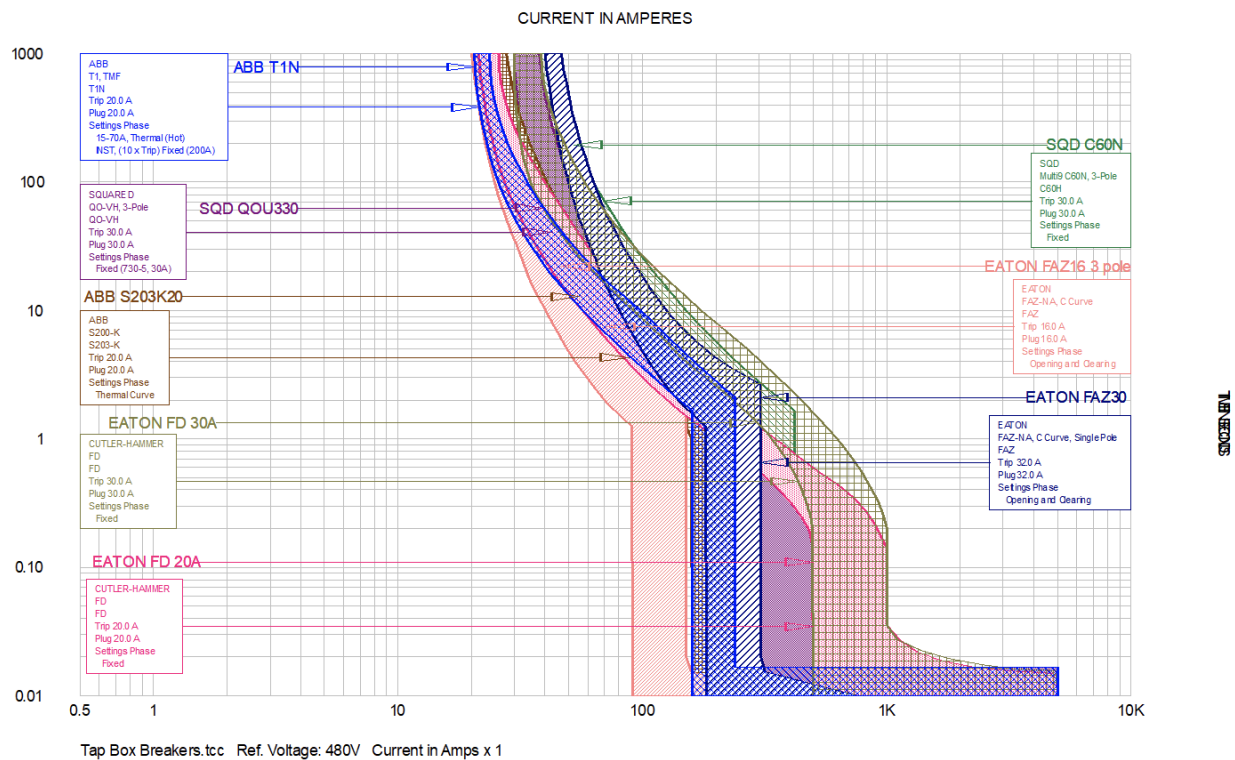

3.7 AC Inrush Current

Maximum AC inrush current from cold power-on shall be limited to no greater than 30A at any AC operating voltage and a temperature of 25C. This specified inrush current shall not include the X-Capacitors charging.

3.8 Efficiency

The efficiency of the rectifiers when measured at an AC input voltage of 208V~277V and with the cooling fans connected (with input and output voltage measured at corresponding connectors, at 25C ambient and after 30 minutes running at full load) shall meet the requirements outlined in Table below.

Load Range (%)	Peak Efficiency (%)	Min Efficiency (%)
30% to 100% of full load	> 97.5%	> 96.5%

	@230, 240, 277V > 96.5% @208V	@230, 240, 277V > 95.5% @208V
10% to 30% of full load	-	94% @208V~277V

Table 2: Efficiency Requirements

3.9 Power Factor

The rectifier shall incorporate an active power factor correction circuit such that the power factor exceeds 0.97 from 30% to 100% loads and when measured at AC input voltage of 208~277V. For loads less than 30% and down to 10% the power factor shall not be less than 0.95.

3.10 Total Harmonic Current Distortion (THD)

For input voltage of 208~277V:

Output load (% of max output load per module)	Maximum ITHD (%)
5-15	20
15-30	10
30-100	5

3.11 DC Output voltage

The DC output voltage of the rectifier shall be fixed at 50V while in normal operation. In battery testing mode, the rectifier output voltage shall be 48V. The rectifier shall supply rated power for the entire range of DC output voltage of 48V to 50V.

3.12 DC Output set point voltage accuracy

The rectifier set point output voltage accuracy at 100% load shall be +/- 0.25% or 0.125V. This can be accomplished by EoL calibration.

3.13 DC Output droop voltage

The rectifier droop voltage (0%-100%) shall be 1V by default. That means output voltage is 50V at 100% load and 51V at no-load.

3.14 DC Output Voltage Ripple & Noise

The DC output voltage ripple and noise shall not exceed 500 mV peak to peak. Ripple and noise are defined as periodic or random signals over a frequency band of 5Hz to 20MHz measured across a steady-state resistive load. Measurements shall be made differentially using an oscilloscope with 20Mhz bandwidth limit enabled.

3.15 Dynamic Response

Under these testing conditions, the DC output voltage shall not vary by more than 1V for undershoot and overshoot with 3mS settling time (with and without capacitive loading on a single unit at power of 10 mF).

Output	step load	Frequency	Transient load rate
+50V	50% step load, 5-50% starting load	20 Hz	1 A/uSec

3.16 Overshoot at Turn on / Turn off

The output voltage overshoot upon the application or removal of AC input voltage, under the specified input voltage defined before, shall not exceed 1V.

3.17 Hold - up Time

The rectifier shall have a hold up time of minimum of 20ms after loss of AC input voltage at 100% load. During the hold up time period, the dc voltage is allowed to drop by 2V.

3.18 Output Over Voltage Protection (OVP)

The rectifier shall shut down for DC output voltage exceeding 52.5V. The reacting time shall not exceed 200 mSec. For DC output voltage shall never exceed 54V.

3.19 Constant current operation

Full power, 3000W, down to 48Vdc without any limitation of time. The rectifier shall go to constant current operation mode in case of overpower. As a result, the dc output voltage start to drop. The rectifier shuts off if its output voltage is lower than 44V for 200mS.

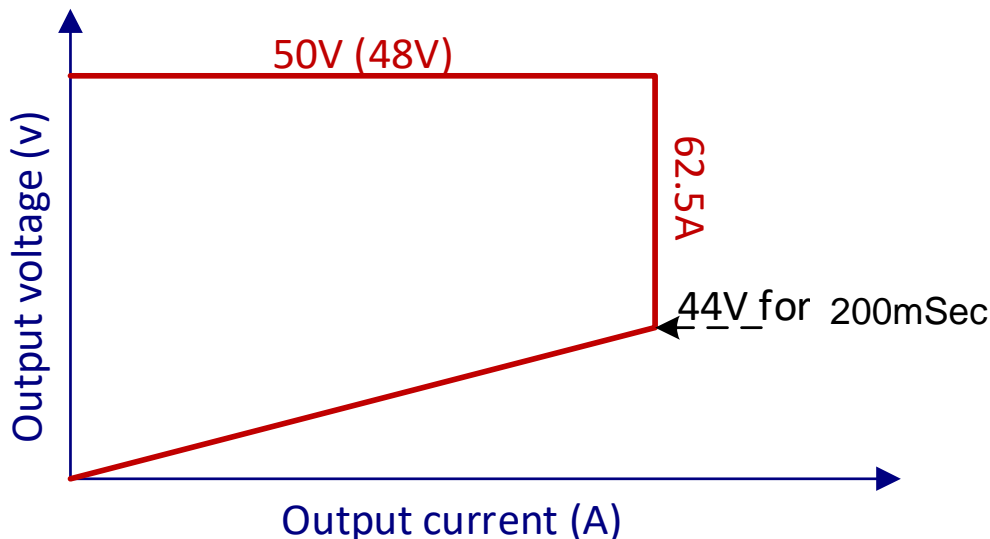

3.20 Output Short-circuit Protection

The rectifier shall employ short-circuit protection to protect the rectifier and attached load in the case of an output short-circuit or other output overload condition.

Open Compute Project • Open Rack V3 Power Shelf

If the rectifier voltage is lower than 10V (short circuit condition), the rectifier shuts off immediately. No component shall damage. The protection shall be implemented with a hiccup mode. it tries to restart 5 times (2 second off, 200mSecond on) and then locks out.

3.21 Over Temperature Protection

The rectifier shall employ over temperature protection for both ambient over temperature and internal thermal temperature to protect the rectifier. The rectifier shall shut down under over temperature condition and recover after certain period after the over temperature condition is removed.

The OTP circuit shall incorporate built in hysteresis such that the power supply does not oscillate on and off due to temperature recovering condition. The OTP event shall be reported as a fault condition.

3.22 Active Current Sharing Accuracy through analog bus.

The rectifiers shall have a dedicated analog bus with slow bandwidth for active current sharing. With the maximum number of rectifiers connected in the system, the current sharing accuracy shall be +/- 2% or better under load > 50% and +/- 5% or better under load >20%.

In the event of Active current sharing gets broken, the PSU shall share the load through voltage drooping. The failure of a module inside the PSU should not affect the load sharing or output voltages of the other supplies still operating. The supplies must be able to load share in parallel and be able to hot-swap.

3.23 Rectifier physical addressing

Four rectifier signal pins are used for physical addressing. There are digital signals that should have internal pull up resistors inside the rectifier. On the power shelf, these pins can be grounded (0) on left open (1) to determine rectifier location as below:

Rectifier location 1-1 (row-column): 0000

Rectifier location 1-2: 0001

Rectifier location 1-3: 0010

.

Rectifier location 2-1: 0110

.

and so on.

3.24 48V/50V output voltage selection

Rectifier output voltage is nominally 50V (droop range 50-51V). When commanded by SW, rectifiers shall change their output voltage to 48V (droop range 47-48V). Default output voltage is 50V.

3.25 LED

The PSU will have a single blue and single amber LED mounted near the PSU handle for accessibility. Following are power supply LED States:

LED 1, Blue LED:

- 1) **Blinking Blue @ 4Hz frequency:** Sync Start State, PSU is ready to turn on its output and awaiting the sync Start signal
- 2) **Solid Blue:** 50V is ON and available
- 3) **No LED:** 50V output off

LED 2, Amber LED:

Open Compute Project • Open Rack V3 Power Shelf

- 1) **Blinking Amber @ 4Hz frequency:** Bootloading
- 2) **Solid Amber:** Primary/Secondary/Fan/bootloading Failure and/or loss of DC output
 - (refer to PSU PMbus registers for specific failures)
- 3) **No LED:** fault NOT present/condition 1 and 2 are false.

- NOTE: toggling PS_ON/AC input power will reset the solid/blinking yellow fault light but will come up again if faults re-occur.
- Only one of the 3 conditions per LED will be applied at ALL time.

Refer to the mechanical drawing for the suggested location of the LEDs.

3.26 Grounding

The protective earth ground pins shall be connected to the safety ground (power supply enclosure). This grounding should be well designed to ensure passing the max allowed Common Mode Noise levels.

Power supply output voltage return *shall not* be connected to Ground.

3.27 Start-up Timing and synchronization Requirements

Under any conditions of dissipative load, capacitive load, temperature, with or without backup voltage connected to the PSU:

- The PSU shall turn on when a valid AC input is provided. Stand-by switch and/or on/off signal are not required. The design of the PFC & DC-DC circuitry, soft starts, etc., will be such that the total time, from when a valid AC input is applied to when the DC output voltage reaches regulation, is a maximum of 4.3 seconds (or 8 second when BBU is running) under any conditions with $V_{in} > 180V_{AC}$ RMS.
- Assuming 2.3Sec max power-up time for PSUs, after AC voltage starts:
 - When there is no dc voltage on the bus (first AC turn on) the power shelf shall be randomized with 0~2 second window to give each power shelf a random turn on time (six PSU turn-on is synchronized).
 - When there is dc voltage on the bus higher than 44V for 0.1 sec (BBU is discharging), the power shelf shall be randomized with 0~5.7 second window to give each power shelf a random turn on time (six PSU turn-on is not synchronized).
- The dc output voltage rise time should be less than 20ms from 10% to 90% of the output voltage at any loading.
- For any loads (from 'no-load' to 'max-load'), the output voltage will rise monotonically from $0V_{DC}$ to $50V_{DC}$, without overshoot or ringing, at any turn on following application of AC input voltage, and anytime when the PSU resumes functionalities after an automatic protection condition (including parallel operations). The output voltage will fall monotonically from $50V_{DC}$ to $0V_{DC}$, without undershoot or ringing, at any AC loss, and at any turn off caused by an automatic protection condition (including parallel operations).
- Output voltage shall never reverse polarity at the turn off (all conditions and converters).
- The PSU shall include a soft-start that promptly resets at any input AC loss > 20ms, or after any automatic protection conditions.
- The power shelf shall turn on with only 1 PSU inserted into any slot.

Item	Description	Min	Max	Units
T_powerup	Time for PSU to be power-up ready	-	2.3	seconds
T_random_noBBU	0-2 second initial turn on random delay without BBU discharging	0	2	seconds

Open Compute Project • Open Rack V3 Power Shelf

TON_noBBU	Time 50V _{DC} turns on after shelf receives AC input without BBU discharging.	2.3	4.3	seconds
T_random_BBU	0-5.7 second turn on random delay after BBU discharging	0	5.7	seconds
TON_BBU	Time 50V _{DC} turns on after shelf receives AC input with BBU discharging.	2.3	8	seconds
TSYNC	After all PSUs in the shelf are ready to start till when 50V _{DC} will start	5	8	msec
TRISE	50V _{DC} rise time	-	20	msec
THoldup	50V _{DC} holdup time	20	-	msec
TAC_3sec	3 sec delay to turn on in case of PSU sync failure	2.9	3.1	seconds

Note: The random numbers above shall be dynamically generated immediately after each AC recycle, and not generated one time and then stored in the EEPROM for future usages.

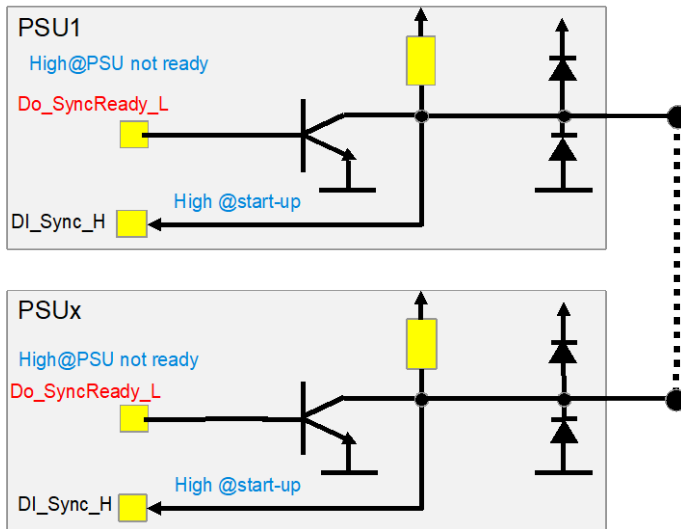

Sync process (only during initial power-up – no BBU):

- Each PSU sets its uC Digital output signal (Do_SyncReady_L) to low when the PSU is ready to turn on the output.
- Only PSU in SLOT #1 generates random timer and set Do_SyncReady_L to low when ready and random timer is finished.
- The PSUs will turn on the output when the uC Digital input sync signal (DI_Sync_H) is high.
- If the PSU in SLOT #1 is failed (or not even installed) at the time of AC is restored, the remaining units start up synchronously at the end of 3Sec (with no random timing), when AC becomes available.

3.28 Surge power capability requirements

The PSU shall meet the following surge power capability requirements.

Surge Power Capability ³ (Average ≤ 3000 W over 10 s)	155% rated power for > 0.5 ms duration 135% rated power for > 5 ms duration 115% rated power for > 50 ms duration
---	---

Open Compute Project • Open Rack V3 Power Shelf

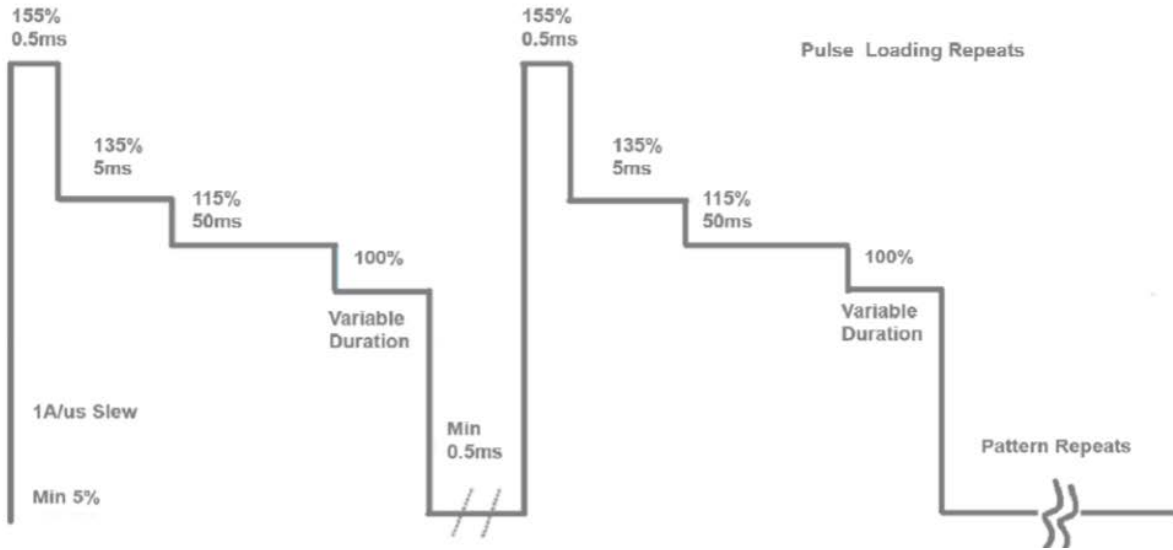

3.29 Power system stability requirements

Please see appendix A for power system stability requirements.

3.30 PSU connector pinout

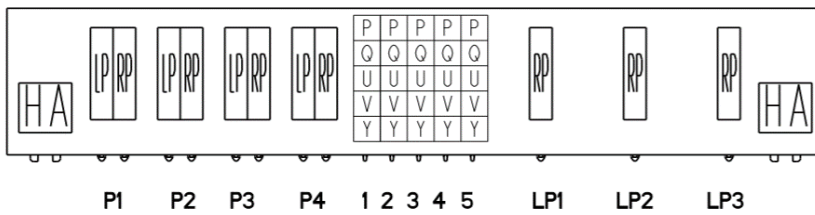
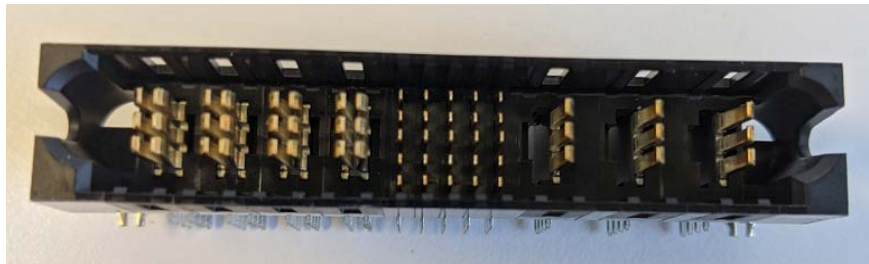

P1 & P2	48V positive
P3 & P4	48V return
LP1	Earth
LP2	ac phase
LP3	ac phase

Note: P3, P4, and LP1 mate first. U3 is short pin.

Date: 15 October 2020

Open Compute Project • Open Rack V3 Power Shelf

PSU Pinout	Signal Name	Type	Bus	Function	Comments
P1	PSU_A0	Input		Address 0 - PSU ID A0	Internal pull up 10k to 3.3V
P2	PSU_A1	Input		Address 1 - PSU ID A1	Internal pull up 10k to 3.3V
P3	PSU_A2	Input		Address 2 - PSU ID A2	Internal pull up 10k to 3.3V
P4	PSU_A3	Input		Address 3 - PSU ID A3	Internal pull up 10k to 3.3V
P5					
Q1	Ground	Ground			
Q2	Alert	Output/ Active Low	individual	Logic "Low"= Fault or Waring Logic "High"=OK	Internal pull up 10k to 3.3V PSU Alert
Q3	Reset	Input/ Active high	individual	Logic "low to High"= Reset the PSU	Should be enabled by SW. Internal pull down 10k resistor.
Q4	RS485_addr0	Input	Share bus		Internal pull up 10k to 3.3V
Q5	RS485_addr1	Input	Share bus		Internal pull up 10k to 3.3V
U1	RS485_addr2	Input	Share bus		Internal pull up 10k to 3.3V
U2	BKP	Output/ Active Low	Share bus		Internal pull up 10k to 3.3V Not used.
U3	PSKILL (Short Pin)	Input/ Active High		Logic "Low"= Output Turn on Logic "High"= Output Turn off	Quick shut down Output, mitigate hot unplug arcing. Internal pull up 10k to 3.3V.
U4	RS485A	BI	Share bus		
U5	RS485B	BI	Share bus		
V1	Ground	Ground			
V2	I2C_SDA	BI	share bus	I2C Data	
V3	I2C_SCL	BI	share bus	I2C Clock	
V4	Ground	Ground	share bus	I2C ground	
V5	PLS (power loss siren)	Output/ Active low	share bus	Logic "Low"= Input is not OK for 45Sec Logic "High"= Input is OK	Internal pull up 10k to 3.3V. All PSUs ORed together.
Y1	ISHARE	Analog	share bus	Main Output current share bus	
Y2	Ground	Ground			

Open Compute Project • Open Rack V3 Power Shelf

Y3	SYNC_START	BI	share bus	Synchronizing turn-on main output	Internal pull up 10k to 3.3V
Y4	VOUT_SEL	Input	share bus	Logic "Low"= Set Output 48V Logic "High"=Set Output 50V	Internal pull up 10k to 3.3V, Default Output is 50V.
Y5	Ground	Ground			

4. Communication

The rectifiers shall communicate to PMC/PMI module through single PMBus (up to 1Mbps) or Top-of-Rack module through ModBus (up to 115kbps). See related Appendices.

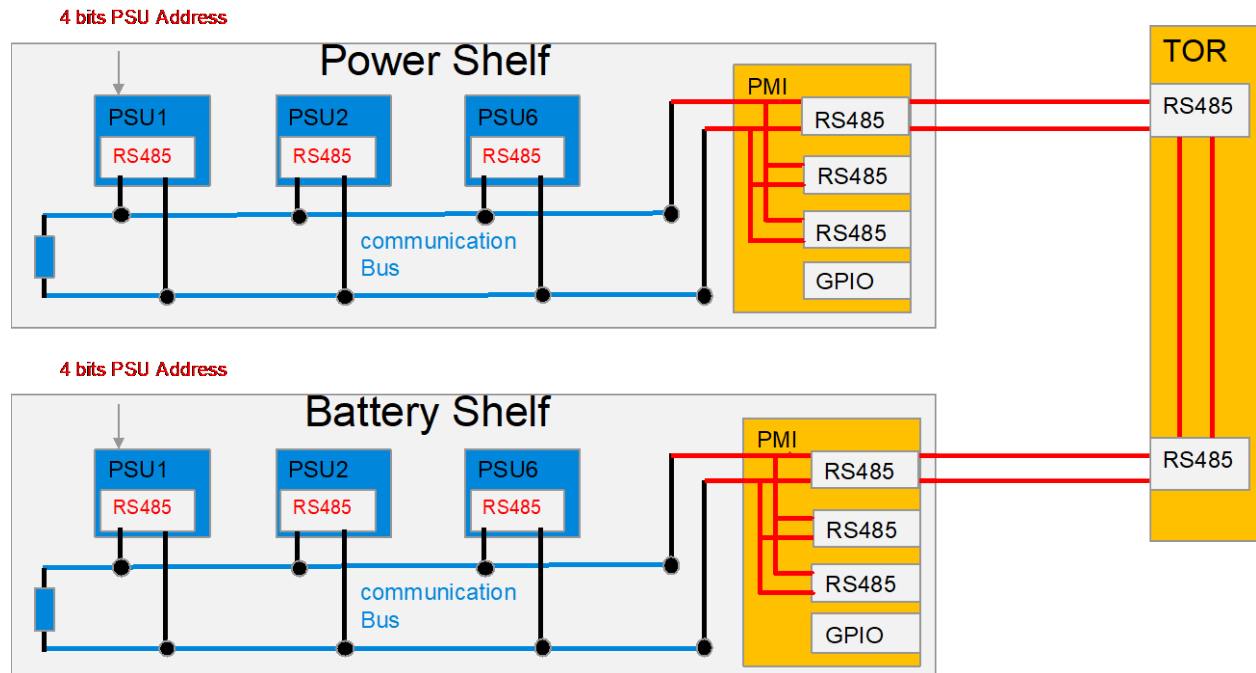

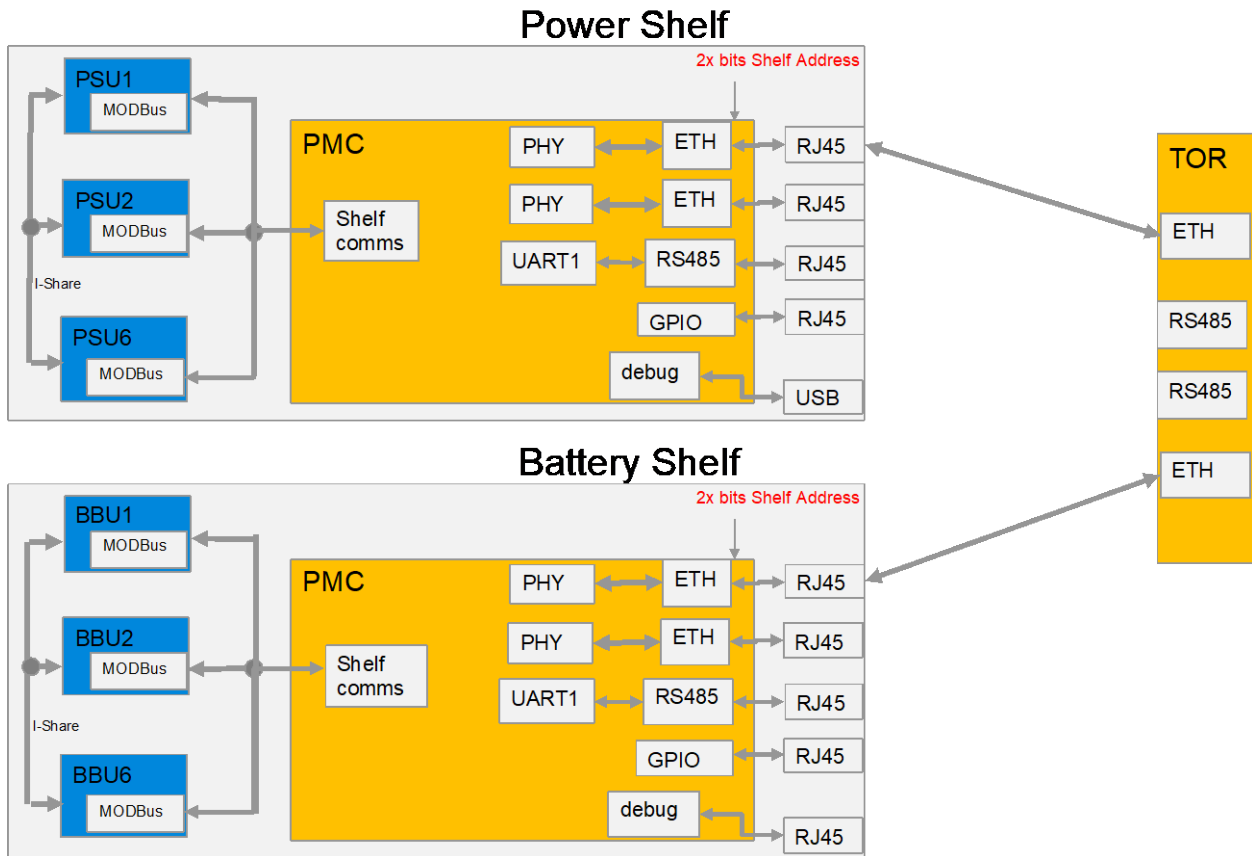

The software interface shall be operational when the AC is present or when the DC output bus is powered up by other power sources.

- Fault conditions
 - Last power failure event
 - Rectifier failure
- Read:
 - Voltage in
 - Current in
 - Voltage out
 - Current out
 - Temperatures
 - Fan speeds
 - Power out
 - Power in
 - Position
 - Serial Number
 - Manufacturer part number
 - Hardware revision
 - Firmware revision
- Write:
 - Clear faults

Open Compute Project • Open Rack V3 Power Shelf

- Upgrades:
 - Upgrade firmware image(s)

4.1 Firmware Upgrade

The interface shall allow the user to re-flash firmware on the device. Firmware upgrade shall result in no power interruption on the shelf level (the unit being upgrade can go offline.) Upgrades can be done 1 rectifier at a time.

4.2 Metering Accuracy

Accurate reporting of input power (power factor, input current, input current harmonics and voltage) and output power (output current and voltage) readings shall be reported via communication system at all rated voltage.

The accuracy shall be maintained across the operating temperature range and between 200Vac and 305Vac.

parameter	Load	Accuracy
AC input power	<10%	±25W
	10-20%	<± 5%
	20-100%	< ±3%
AC input current	<10%	±0.5A
	10-20%	< ±2%
	20-100%	< ±1%
AC input current THD	<10%	±10%
	10-20%	±2%
	20-100%	±1%
Power factor	<10%	±0.1
	10-20%	±0.02
	20-100%	±0.01
AC input voltage	0-100%	±1%
output voltage	0-100%	±0.5%
output current	0-100%	±1%
output power	<10%	±25W
	10-20%	<3%
	20-100%	<2%

--	--	--

4.3 Last Power Failure Fault Conditions

The interface shall record and make available the total number of seconds since the last power failure event defined by one of the following conditions:

- Output voltage below 44V.
- Output voltage above 54V.
- Output current above over current protection level
- Fan failure
- Temperature > 55C

4.4 Rectifier Failure

The interface shall export any condition in which a single rectifier needs servicing.

4.5 Identification

The interface shall export its hardware and firmware version identification as well as a serial number uniquely identifiable to the device itself.

4.6 Position

The interface shall export the position of each rectifier and ID of the shelf that it is in.

4.7 Blackbox Function

For the following section please refer to the latest Communication Specification for detailed information. The black box function shall store key important data to be used when a fault occurs.

- Must store data in memory and be able to withstand several read/write cycles
- PSU must be able to store failure data before the PSU turns off/fails even in catastrophic failure events both on primary and secondary side. Hold up time of the blackbox microcontroller must be able to store all the information and then shutdown.
- Last 4 events stored in memory.
- AC input current, AC input voltage, Input Power, Power factor, iTHD, DC output voltage, DC output current,
- Temperature readings, fan Speed, input voltage, output voltage, bulk voltage, various error codes from all the different converters (OTP, OVP, OCP,UVP), and warnings.
- BBU signals at time of failure (fail, charge_enable, BBU voltage, etc)
- Total run time of PSU
- Run time since last turn on
- Real time stamping
- Number of AC power cycles
- Number of AC outages (can be determined by going into backup without counting the battery test conditions)

Power supply event data is saved to the Black Box for the following events:

Any events that caused the Main Output to shut down:

- Main Output over voltage fault
- Main Output under voltage fault
- Main Output over current fault

Open Compute Project • Open Rack V3 Power Shelf

- Main Output short circuit fault
- Fan failure
- Over temperature fault ☐

Any events that caused the AC input to be bad:

- AC Input under voltage fault
- AC Input over voltage fault
- AC Input out of range frequency fault ☐

Any fault events that caused the Discharger to shut down:

- Discharger over voltage fault
- Discharger under voltage fault
- Discharger over current fault ☐

Any fault events that caused the Charger to shut down:

- Charger over voltage fault
- Charger under voltage fault
- Charger over current fault
- Charger short circuit fault
- Charger failure
- Charger timeout

4.7.1 Fault Log History

The FAULT_LOG_HISTORY is used to read the 242 byte event data of the unit. The fault log history data stores up to 4 event data sets. If the event data sets exceed 4, the oldest data set shall be removed to give way for the latest data set (first in, first out). Unused history data sets shall have a value of zero for all registers.

This command is using MODBUS Function Read File Record. Each data set is a file record containing up to 242 bytes.

Here is a sample table of the power supply event data which contains up to 242 bytes of data:

Registers	Size in Byte
PSU Status Register	2
General Alarm Status Register	2
PFC Alarm Status Register	2
Secondary Alarm Status Register	2
Discharger Alarm Status Register	2
Aux Alarm Status Register	2
Temperature Alarm Status Register	2
Fan Alarm Status Register	2
Communication Alarm Status Register	2
PSU_Input Voltage AC	2
PSU_Input Current AC	2
PSU_Output Voltage (main converter)	2
PSU_Output Current (main converter)	2

Open Compute Project • Open Rack V3 Power Shelf

AC Line Frequency	1
TOTAL_TIME	4
TIME_SINCE_LAST_ON	4
AC Power Cycles (# of times of cold start)	2
AC Outages (# of times step-up converter turns on due to AC input out of range, not including SoH test)	2
AC Input Voltage (20 samples @ 1ms)	40
AC Input Current (20 samples @ 1ms)	40
Main Output Voltage (20 samples @ 1ms)	40
Main Output Current (20 samples @ 1ms)	40
Temp0 – Inlet (5 samples @ 5 sec)	10
Temp1 – Outlet (5 samples @ 5 sec)	10
RPM Fan 0 (5 samples @ 5 sec)	10
Time stamping	4
Power factor	2
Input current total harmonics	2
<i>Total</i>	<i>242</i>

5. Environment

5.1 Temperature

- Operational or cold aisle (inlet) temperature: -5C to +45C
- Non-operational: -40C to +85C

5.2 Humidity

- Operational : 10-90% RH non-condensing
- Non-operational : 5-93% RH non-condensing

5.3 Altitude

- Operational : 0-3050m
- Non-operational : 0-12000m

5.4 Acoustic Noise

- ~~≤ 55 dBA at maximum operation point~~
- Target sound pressure should not exceed 85dBA when fan modules are running at full speed and operating within the defined environmental envelope

5.5 Vibration

5.5.1 Operational

Equipment must satisfy .17G vertical z-axis: .12G horizontal x- and y- axes swept from 5-500-5 Hz, 5 sweeps in all, at 1 octave/min. Reference spec (IEC 60068-2-6 Test Fc). Equipment shall be running diagnostic test while sweep is going on.

5.5.2 Non-Operational

Packaged unit must satisfy ASTM D 4169 Level 2 Schedule E using 60min Truck then 120 min Air Power Spectrum

Unpackaged unit, attached to a shaker using product's mounting points, must survive 3 hours random vibration per the following PSD Break Points.

Frequency	<u>G²/Hz</u>
1	.00004
4	.00675
8	.00759
15	.0273
17.5	.0102
26	.148
34	.000355
122	.000006

Grms = .92

Table 5: Vibration Spectrum

5.6 Shock

5.6.1 Operational

Equipment must satisfy 10 +/- shocks, 3.5G, 11 msec half-sine, in the x-y- and z- axes. Ref spec (IEC 60068-2-27 Test Ea). Equipment shall be running diagnostic test during shock events.

5.6.2 Non-Operational

Packaged unit must satisfy ASTM D4169 Schedule A Level 2, 6 impacts, before and after shipping vibrate with the last impact at twice the height on the most typical surface to be dropped on.

Unpackaged unit, attached to a test machine using product's mounting points, must survive 3 +/- Shocks, 7.5 G, 19 msec half sine, in the vertical axis only

6. Thermal

6.1 Operational

6.1.1 **Airflow direction:** Front-to-back

Open Compute Project • Open Rack V3 Power Shelf

- 6.1.2 **DeltaT:** This is the air-side temperature difference across the rectifier assembly and represents airflow usage (CFM) in relation to heat loss in the device (W). Efficient use of airflow is critical to meeting facility-level requirements, and the following temperature difference targets are outlined.

Temperature difference $\geq 22^{\circ}\text{F}$ across 30~85% load range and up to 35°C inlet/ambient and 3050m (10,000ft) above sea-level

- 6.1.3 **Thermal margin:** While efficient use of airflow is important for thermal design, reserving adequate margins on components is equally critical. These margins should be defined with respect to de-rated values, as appropriate. Following are the requirements.

Component thermal margin of $\geq 7\%$ or $\geq 5^{\circ}\text{C}$ under worst-case condition (100% load, input voltage lowest, output voltage lowest) and up to 30°C inlet/ambient and 3050m (10,000ft) above sea-level. Target whichever value is larger.

Component thermal margin of $\geq 4\%$ or $\geq 3^{\circ}\text{C}$ under worst-case condition (100% load, input voltage lowest, output voltage lowest), at greater than 30°C inlet/ambient and up to 3050m (10,000ft) above sea-level. Target whichever value is larger.

Margin to de-rated temperatures should account for associated differences in reading and measurement location. Impact to reliability should also be considered when determining required margin.

6.2 Thermal design requirements

- 6.2.1 **Sensor accuracy:** For discrete and critical sensors (such as ambient temperature), an accuracy of $\pm 2^{\circ}\text{C}$ is required ($\leq \pm 1^{\circ}\text{C}$ is preferred). Exhaust and inlet temperature sensors are required in the unit. If a component does not have an integrated temperature sensor, and uses a proxy, need to target an accuracy $\leq \pm 5^{\circ}\text{C}$ ($\leq \pm 2^{\circ}\text{C}$ is preferred). If this component is temperature sensitive, thermal margin requirements defined above should account for sensor inaccuracy.
- 6.2.2 **System fan:** Should be sized to support operation across environmental and loading envelopes, with an adequate operating range (speed) to achieve requirements outlined in this document. The fan should also have adequate overhead to accommodate back-pressure resulting from shelf design, rack-level accessories and data center operation. In general, head room to overcome a back-pressure of ≥ 0.25 inches of water is highly recommended (placeholder value; to be verified and updated). When the rectifier is plugged in, the fan should stay operational irrespective of load and maintain front-to-back airflow direction (overcome potential back-pressure). Mounting of the fan must meet any vibration and acoustic criteria and should not violate any physical constraints outlined. The fan should be included within the power supply enclosure.
- 6.2.3 **Surface temperature:** To make the rectifier assembly safe for handling in-operation, accessible surfaces should not exceed a temperature of 70°C .

6.3 Fan Failure

If a fan fails, the rectifier must indicate the failure with a signal that will be reported via SW as well as an LED indicator on the front panel. The rectifier shall not need to shut down because of a failed fan and only shut down if there is a fault, ie. over-temperature fault.

6.4 Rectifier Thermal Monitoring

Each rectifier shall provide the following parameters via the defined communication protocol. The following thermal parameters must be available for each rectifier and labeled accordingly:

- Inlet temperature
- Exhaust temperature
- Fan RPM (average, if >1 fan used in the rectifiers); percent is acceptable as long as full speed rpm is provided at some point
- Fan fail signals

7. Mechanical

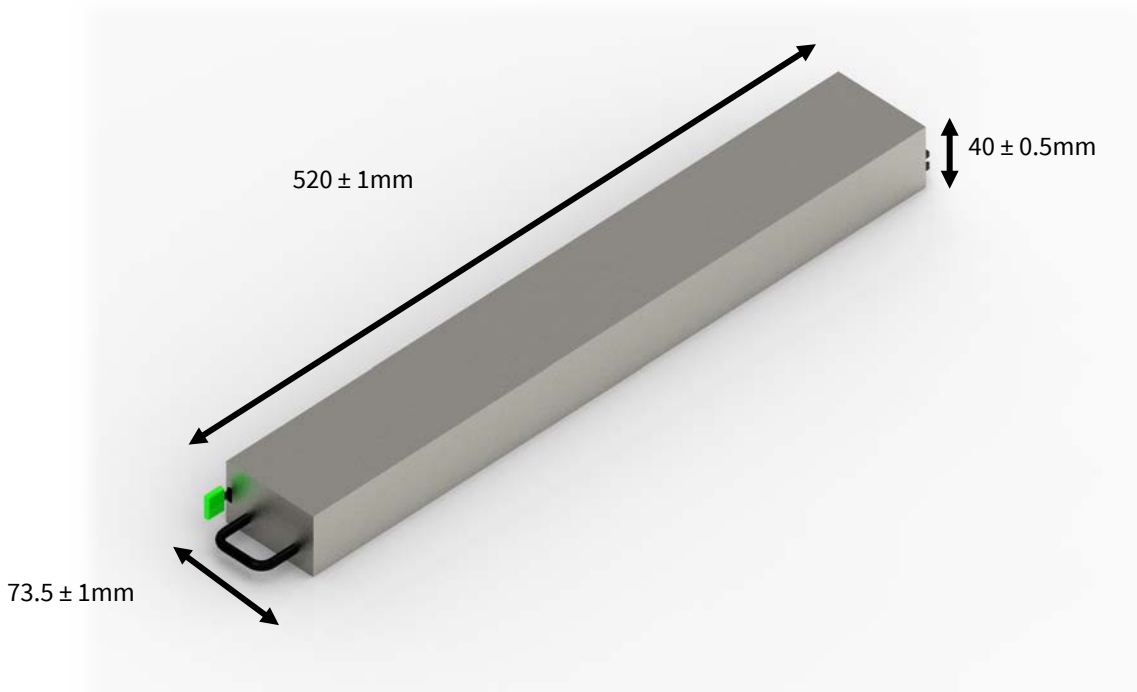

7.1 Physical Dimensions

The sheet metal material shall be steel, pre-plated hot-dip zinc coated, with .8-1mm of thickness.

The rectifier dimensions are:

40mm tall, 73.5mm wide, and 520mm deep (nominal dimensions). Please see the figure above for tolerances.

The PSU mechanical chassis is composed by a base and a cover assembled using flathead screws: no rivets are allowed (the PSU must be able to be opened by using a screwdriver).

7.2 Indicators

See LED section.

7.3 Latch & Handle

Open Compute Project • Open Rack V3 Power Shelf

A latch and handle are required for power supply removal. The latch shall be attached in the location shown, to interface with the cutout in the chassis. The latch and/or handle designs may vary, but the latch must be Pantone 285C. Please note that the PSU will be heavy, and the handle should be sturdy enough to carry the entire weight of the PSU.

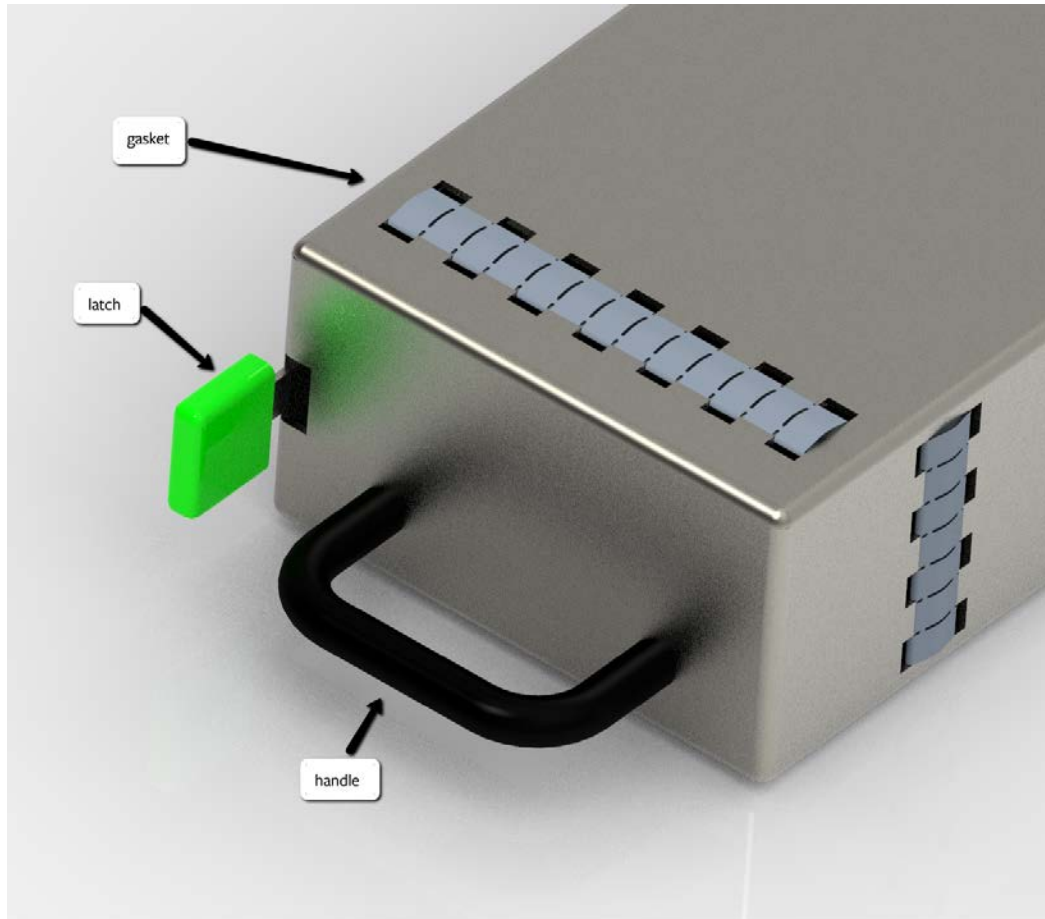

7.4 Chassis Interface

The handle of the rectifier may not protrude from the front surface of the rectifier by more than 25mm. The latch shall be located on the left side of the rectifier and interface with a rectangular hole in the chassis wall (please refer to the 3D drawing for latch location on the rectifier). They should only lock into place when a good electrical contact is made on the rear blind mate connectors. This scheme will allow a quick installation of the Power Supply in the tray, and without the need of using a screwdriver. The front face where the handle is attached should have perforated holes to allow airflow for the fan(s). Spring finger gaskets should be installed on at least three sides to ensure solid EMI containment. The spring finger gaskets should be placed within 65mm of the front surface of the power supply.

7.5 Rear Blind mate connector

The rear blind mate connector of the PSU shall be Amphenol 10127396-01U1520LF or equivalent. This is a R/A plug, PwrBlade ULTRA HD connector with 4 high power pins, 25 signal pins, and 3 low power pins. Please refer to the drawing for more details.

Open Compute Project • Open Rack V3 Power Shelf

The connector position within the PSU is fixed in x, y, and z direction according to the 3D drawing. This cannot be altered due to mix-and-match requirements for the power supplies into the shelf.

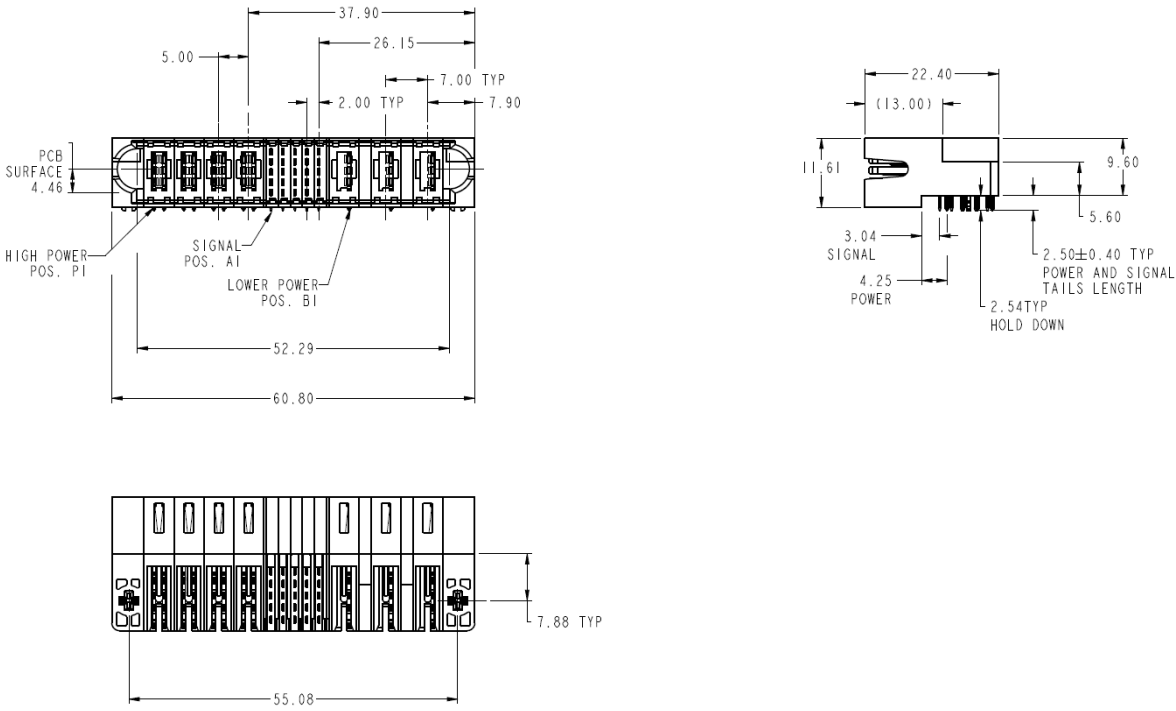

8. Reliability and Quality

8.1 Derating Design

A comprehensive stress analysis and derating design shall be performed for the rectifier. The stress analysis shall include electrical, thermal, and mechanical stresses with actual measurements. The components in the rectifier design shall be properly derated and to meet the derating guideline as specified in IPC-9592B "Requirements for Power Conversion Devices for the Computer and Telecommunication Industries", Appendix A or supplier's own derating guideline.

8.2 Reliability Prediction

A reliability prediction shall be performed for the rectifier using Telcordia SR-332 Issue 2 Method I, Case I (Part Count). The rectifier shall have a minimum MTBF= 1,000,000 hrs at 30C, 100% load per IPC-9592B without fan.

8.3 Design Failure Mode and Effect Analysis (DFMEA)

A comprehensive DFMEA shall be performed for the rectifier. The DFMEA report shall include a list of critical components, risk areas, and corrective actions taken.

8.4 High Accelerated Life Test (HALT)

A comprehensive HALT shall be performed on the rectifiers. The HALT equipment, testing procedure, sample size, testing report and documentation, and root cause analysis and corrective action

Open Compute Project • Open Rack V3 Power Shelf

requirements shall follow the requirements as specified in IPC-9592B, Section 5.2.3 and Appendix D.

8.5 Burn-In (BI) and Ongoing Reliability Testing (ORT)

Either 100% burn-in or 100% HASS (Highly Accelerated Stress Screening) test shall be performed at the beginning of the rectifier mass production. Either BI or HASS could be chosen based on supplier's capability and preference.

The detailed requirements for BI and HASS test durations, duration reduction plan, and test profile shall follow the requirements as specified in IPC-9592B, Appendix E for Category 1 PCD products.

After meeting the acceptable failure rate criteria as listed in Table E-1 of IPC-9592B Appendix E, the 100% BI or HASS could be reduced to sampling BI or HASA.

Ongoing Reliability Testing (ORT) shall be performed on the rectifiers when BI or HASS test is reduced from 100% to sampling and when BI or HASS is eliminated after at least one (1) year. The detailed ORT plan and requirements shall follow the requirements as specified in IPC-9592B, Appendix E, Section E.2.3.

8.6 Manufacturing Quality

It is required to meet the quality process requirements as specified in IPC-9592B, Section 6 ("Quality Process"), which include PFMEA, statistical process control (SPC), corrective action process, yield control, materials traceability, product change notice (PCN), qualification of change, etc.

9. Compliance requirements

The power supply unit shall be designed for compliance to allow worldwide deployment. Additionally, the manufacturer is fully responsible for:

- ensuring the complete compliance of the power supply shelf in the environment it is intended to function (as described by the Rack Spec)
- maintaining and updating the power supply shelf safety reports to current requirements and all new released requirements.
- all design and recertification costs required to update the power supply to meet the new requirements.
- Meeting EMC requirements
- Meeting Safety requirements

The manufacturer is responsible for obtaining the safety certifications specified below.

9.1 Safety Standards

The product is to be designed to comply with the latest edition, revision, and amendment of the following standards. The product shall be designed such that the end user could obtain the safety certifications: UL 62368-1, IEC 62368-1 and EN 62368-1; hazard-based performance standard for Audio video, IT & Communication Technology Equipment

The manufacturer shall obtain the following safety certifications for the power supply shelf as applicable. Only requirements that absolutely rely on or are affected by the system may be left to the system level evaluation [i.e. minimize Conditions of Acceptability]. Below are common requirements for North America and Europe. For other countries, different certifications may be required:

- UL or an equivalent NRTL for the US with follow-up service (e.g. UL or CSA).
- CB Certificate and test report issued by CSA, UL, VDE, TUV or DEMKO

Open Compute Project • Open Rack V3 Power Shelf

- CE Marking for EU

9.1.1 Component Safety requirements

Following are the safety requirements for major components:

- All Fans shall have the minimum certifications: UL and TUV or VDE.
- All current limiting devices shall have UL and TUV or VDE certifications and shall be suitable rated for the application where the device in its application complies with IEC/UL 62368-1.
- All printed wiring boards shall be rated UL94V-0 and be sourced from a UL approved printed wiring board manufacturer.
- All connectors shall be UL recognized and have a UL flame rating of UL94V-0.
- All wiring harnesses shall be sourced from a UL approved wiring harness manufacturer. SELV Cable to be rated minimum 80V, 125C.
- Product safety label must be printed on UL approved label stock and printer ribbon. Alternatively, labels can be purchased from a UL approved label manufacturer.
- The product must be marked with the correct regulatory markings to support the certifications that are specified in this document.

9.2 EMC Requirements

The power supply shall meet the following requirements in the latest edition of standards when operating under typical load conditions and with all ports fully loaded;

The Power supply integrated into the shelf is called the component power supply. Manufacturer shall provide the proof of compliance for the component power supply that are required for spare parts shipment. The component power supply shall not contribute any noncompliant conditions to the end-use product.

If at any time it is found that a supplier's component power supply causes the end-use product to fail emissions and/or immunity testing, the supplier will be instructed to investigate and resolve the problem. The power shelf shall have minimum 6dB margin from the Class A limit for the radiated and conducted emissions. Depending on the system manufacturer's design goals and business needs, more margin may be required when it is integrated into the final end system.

The following EMC Standards (the latest version) are applicable to the product.

- FCC /ICES-003
- CISPR 32/EN55032
- CISPR 35/EN55035 - Immunity
- EN61000-3-2 - Harmonics
- EN61000-3-3 - Voltage Flicker
- VCCI
- KN 32 and KN35

Each individual basic standard for immunity test has the following minimum passing requirement. Higher level of passing criteria may be applied depending on the system manufacturer's design goals and business needs.

- EN61000-4-2 Electrostatic Discharge Immunity
 - Contact discharge: >4kV
 - Air discharge: >8kV
- EN61000-4-3 Radiated Immunity
 - > 3V/m
- EN61000-4-4 Electrical Fast Transient Immunity
 - AC Power Line: >1kV
 - Signal Line: >0.5kV
- EN61000-4-5 Surge
 - AC Power Line: >1kV (Line-to-line), >2kV (Line-to-earth)

Open Compute Project • Open Rack V3 Power Shelf

- Signal Port: >1kV
- EN61000-4-6 Immunity to Conducted Disturbances
 - DC Power Line: > 3Vrms
- EN61000-4-8 Power Frequency Magnetic Field Immunity, when applicable
 - > 1A/m
- EN61000-4-11 Voltage dip and sag

9.3 Environmental Compliance

The power shelf (including all components inside) shall comply with the following minimum environmental requirement and manufacturer shall provide full material disclosure, Declaration of Conformity and technical documentations to demonstrate compliance. The system manufacture may have additional requirements depending on its design goals and business needs.

- RoHS Directive (2011/65/EU and 2015/863/EU); aims to reduce the environmental impact of EEE by restricting the use of certain substances during manufacture
- REACH Regulation (EC) No 1907/2006; registration with the European Chemicals Agency (ECHA), evaluation, authorization and restriction of chemicals.
- Halogen Free: IEC 61249-2-21, Definition of Halogen Free, 900ppm for Br or Cl, or 1500ppm combined
- US SEC conflict mineral regulation to source mineral materials from socially responsible countries, if applicable
- Waste Electrical and Electronic Equipment (“WEEE”) Directive (2012/19/EU) if applicable; aims to reduce the environmental impact of EEE by restricting the use of certain substances during manufacture

9.4 Documentation

The manufacturer shall provide reproducible copies of all pertinent documentation relating to the following:

- Product Information
- Bill of Materials
- Schematics
- functional test report
- Final Compliance Approval
- NRTL certificate and report, Conditions of Acceptability and test report plus User documentation that explains safe installation and operating procedures.
- CB Certificate and report, including schematics
- Manufacturer’s Declaration of Conformity to EN 62368-1, EN55032, EN55035 and ROHS
- FCC Part 15 Class A and CISPR32 Class A test data
- Declaration of Conformity to EN 61000-3-2 Class A and test report including waveforms and harmonic output levels.
- Other applicable certificates required by the system manufacturer.

Attachment A: Power Supply Impedance Specification

Attachment B: PSU PMBUS Software Interface Specification

Attachment C: ModBus Software Interface Specification and register map