



OPEN
Compute Project

OCP NIC 3.0 Design Specification

Version [0.840-83](#)

Author: OCP Server Workgroup, OCP NIC subgroup

Style Definition: Heading 2

Style Definition: List Paragraph: Indent: Left: 0.25", First line: 0"

Style Definition: Caption

Table of Contents

1 Overview	10
1.1 License	10
1.2 Acknowledgements	11
1.3 References	12
1.3.1 Trademarks	13
1.4 Acronyms	14
1.5 Background	16
1.6 Overview	1918
1.6.1 Mechanical Form Factor Overview	1918
1.6.2 Electrical Overview	2120
1.6.2.1 Primary Connector	2120
1.6.2.2 Secondary Connector	2221
1.7 Non-NIC Use Cases	2221
2 Mechanical Card Form Factor	2522
2.1 Form Factor Options	2522
2.1.1 SFF Faceplate Configurations	2824
2.1.2 LFF Faceplate Configurations	3428
2.2 Line Side I/O Implementations	3932
2.3 Top Level Assembly (SFF and LFF)	4033
2.4 Faceplate Subassembly (SFF and LFF)	4134
2.4.1 Faceplate Subassembly – Exploded View	4134
2.4.2 Faceplate Subassembly – Bill of Materials (BOM)	4134
2.4.3 SFF Generic I/O Faceplate	4336
2.4.4 LFF Generic I/O Faceplate	4537
2.4.5 Ejector Lever (SFF)	4738
2.4.6 Ejector Levers (LFF)	4738
2.4.7 Ejector Lock (SFF and LFF)	4839
2.4.8 Ejector Bushing (SFF and LFF)	4839
2.4.9 Ejector Wave Washer (SFF and LFF)	4940
2.5 Card Keep Out Zones	5041
2.5.1 SFF Keep Out Zones	5041
2.5.2 LFF Keep Out Zones	5744
2.6 Baseboard Keep Out Zones	6346
2.7 Insulation Requirements	6447
2.7.1 SFF Insulator	6447
2.7.2 LFF Insulator	6748
2.8 Critical-to-Function (CTF) Dimensions (SFF and LFF)	7251
2.8.1 CTF Tolerances	7251
2.8.2 SFF Pull Tab CTF Dimensions	7251
2.8.3 SFF OCP NIC 3.0 Card with Ejector Latch CTF Dimensions	7453
2.8.4 SFF OCP NIC 3.0 Baseboard CTF Dimensions	7554
2.8.5 LFF OCP NIC 3.0 Card CTF Dimensions	7756
2.8.6 LFF OCP NIC 3.0 Baseboard CTF Dimensions	7857
2.9 Labeling Requirements	8059
2.9.1 General Guidelines for Label Contents	8059
2.9.2 MAC Address Labeling Requirements	8160
2.9.2.1 MAC Address Label Example 1 – Quad Port with Single Host, Single Managed Controller	8160
2.9.2.2 MAC Address Label Example 2 – Octal Port with Single Host, Dual Managed Controllers	8261
2.9.2.3 MAC Address Label Example 3 – Quad Port with Dual Hosts, Dual Managed Controllers	8462
2.9.2.4 MAC Address Label Example 4 – Single Port with Quad Host, Single Managed Controller	8562
2.10 Mechanical CAD Package Examples	8764
3 Electrical Interface Definition – Card Edge and Baseboard	8865
3.1 Card Edge Gold Finger Requirements	8865
3.1.1 Gold Finger Mating Sequence	8966
3.2 Baseboard Connector Requirements	9370
3.2.1 Right Angle Connector	9370
3.2.2 Right Angle Offset	9471

3.2.3	Straddle Mount Connector	9474
3.2.4	Straddle Mount Offset and PCB Thickness Options	9673
3.2.5	LFF Connector Locations	9774
3.3	Pin Definition	9774
3.3.1	Primary Connector	9875
3.3.2	Secondary Connector	10077
3.4	Signal Descriptions	10178
3.4.1	PCIe Interface Pins	10178
3.4.2	PCIe Present and Bifurcation Control Pins	10683
3.4.3	SMBus Interface Pins	11087
3.4.4	NC-SI over RBT Interface Pins	11188
3.4.5	Scan Chain Pins	11895
3.4.6	Power Supply Pins	125402
3.4.7	USB 2.0 (A68/A69) – Primary Connector Only	128405
3.4.8	UART (A68/A69) – Secondary Connector Only	130407
3.4.9	RFU[1:4] Pins	132409
3.5	PCIe Bifurcation Mechanism	133410
3.5.1	PCIe OCP NIC 3.0 Card to Baseboard Bifurcation Configuration (PRSN#A#, PRSN#B[3:0]#)	133410
3.5.2	PCIe Baseboard to OCP NIC 3.0 Card Bifurcation Configuration (BIF[2:0]#)	133410
3.5.3	PCIe Bifurcation Decoder	134411
3.5.4	Bifurcation Detection Flow	138413
3.5.5	PCIe Bifurcation Examples	139414
3.5.5.1	Single Host (1 x16) Baseboard with a 1 x16 OCP NIC 3.0 Card (Single Controller)	139414
3.5.5.2	Single Host (2 x8) Baseboard with a 2 x8 OCP NIC 3.0 Card (Dual Controllers)	140415
3.5.5.3	Quad Host (4 x4) Baseboard with a 4 x4 OCP NIC 3.0 Card (Single Controller)	141416
3.5.5.4	Quad Host (4 x4) Baseboard with a 4 x4 OCP NIC 3.0 Card (Quad Controllers)	142417
3.5.5.5	Single Host (1 x16, no Bifurcation) Baseboard with a 2 x8 OCP NIC 3.0 Card (Dual Controller)	143418
3.6	PCIe REFCLK and PERST# Mapping	144419
3.6.1	SFF PCIe REFCLK and PERST# Mapping	146420
3.6.2	LFF PCIe REFCLK and PERST# Mapping	149423
3.6.3	REFCLK and PERST# Mapping Expansion	153425
3.7	Port Numbering and LED Implementations	164426
3.7.1	OCP NIC 3.0 Port Naming and Port Numbering	164426
3.7.2	OCP NIC 3.0 Card LED Configuration	164426
3.7.3	OCP NIC 3.0 Card LED Ordering	166428
3.7.4	Baseboard LEDs Configuration over the Scan Chain	167429
3.8	Power Capacity and Power Delivery	167429
3.8.1	NIC Power Off	168430
3.8.2	ID Mode	168430
3.8.3	Aux Power Mode (S5)	168430
3.8.4	Main Power Mode (S0)	168430
3.9	Power Supply Rail Requirements and Slot Power Envelopes	169431
3.10	Hot Swap Considerations for +12V_EDGE and +3.3V_EDGE Rails	170432
3.11	Power Sequence Timing Requirements	171433
3.12	Digital I/O Specifications	177435
4	Management and Pre-OS Requirements	178436
4.1	Sideband Management Interface and Transport	178436
4.2	NC-SI Traffic	179437
4.3	Management Controller (MC) MAC Address Provisioning	179437
4.4	Temperature Reporting	181438
4.5	Power Consumption Reporting	183440
4.6	Pluggable Transceiver Module Status and Temperature Reporting	183441
4.7	Management and Pre-OS Firmware Inventory and Update	183441
4.7.1	Secure Firmware	185442
4.7.2	Firmware Inventory	185442
4.7.3	Firmware Inventory and Update in Multi-Host Environments	185442
4.8	NC-SI Package Addressing and Hardware Arbitration Requirements	185442
4.8.1	NC-SI over RBT Package Addressing	185442

4.8.2	Arbitration Ring Connections.....	186 443
4.9	SMBus 2.0 Addressing Requirements.....	186 443
4.9.1	SMBus Address Map.....	186 443
4.10	FRU EEPROM.....	188 444
4.10.1	FRU EEPROM Address, Size and Availability.....	188 444
4.10.2	FRU EEPROM Content Requirements.....	188 444
4.10.3	FRU Template.....	192 448
5	Routing Guidelines and Signal Integrity Considerations.....	192448
5.1	NC-SI over RBT.....	192 448
5.1.1	Timing Budget.....	192 448
5.2	SMBus 2.0.....	192 449
5.3	PCIe.....	193 449
5.3.1	Channel Requirements.....	193 449
5.3.1.1	REFCLK requirements.....	193 449
5.3.1.2	Add-in Card Electrical Budgets.....	193 449
5.3.1.3	Baseboard Channel Budget.....	193 449
5.3.1.4	SFF-TA-1002 Connector Channel Budget.....	193 449
5.3.1.5	Differential Impedance (Informative).....	193 449
5.3.2	Test Fixtures.....	194 450
5.3.2.1	Load Board.....	194 450
5.3.2.2	Baseboard.....	195 451
5.3.3	Test Methodology.....	195 451
5.3.3.1	Test Setup.....	195 451
6	Thermal and Environmental.....	196452
6.1	Airflow Direction.....	196 452
6.1.1	Hot Aisle Cooling.....	196 452
6.1.2	Cold Aisle Cooling.....	197 453
6.2	Thermal Design Guidelines.....	198 454
6.2.1	SFF Card ASIC Cooling – Hot Aisle.....	198 454
6.2.2	LFF Card ASIC Cooling – Hot Aisle.....	201 457
6.2.3	SFF Card ASIC Cooling – Cold Aisle.....	203 459
6.2.4	LFF Card ASIC Cooling – Cold Aisle.....	206 462
6.3	Thermal Simulation (CFD) Modeling.....	208 464
6.4	Thermal Test Fixture.....	208 464
6.4.1	Test Fixture for SFF Card.....	209 465
6.4.2	Test Fixture for LFF Card.....	211 467
6.4.3	Test Fixture Airflow Direction.....	213 469
6.4.4	Thermal Test Fixture Candlestick Sensors.....	213 469
6.5	Card Sensor Requirements.....	215 471
6.6	Card Cooling Tiers.....	215 471
6.6.1	Hot Aisle Cooling Tiers.....	215 471
6.6.2	Cold Aisle Cooling Tiers.....	215 471
6.7	Non-Operational Shock & Vibration Testing.....	216 472
6.7.1	Shock & Vibe Test Fixture.....	216 472
6.7.2	Test Procedure.....	216 472
6.8	Dye and Pull Test Method.....	217 473
6.9	Gold Finger Plating Requirements.....	219 475
6.9.1	Host Side Gold Finger Plating Requirements.....	219 475
6.9.2	Line Side Gold Finger Durability Requirements.....	219 475
7	Regulatory.....	220476
7.1	Required Compliance.....	220 476
7.1.1	Required Environmental Compliance.....	220 476
7.1.2	Required EMC Compliance.....	220 476
7.1.3	Required Product Safety Compliance.....	221 477
7.1.4	Required Immunity (ESD) Compliance.....	221 477
7.2	Recommended Compliance.....	221 477
7.2.1	Recommended Environmental Compliance.....	221 477
7.2.2	Recommended EMC Compliance.....	222 478

8 Revision History	223179
--------------------------	------------------------

List of Figures

Figure 1: Representative SFF OCP NIC 3.0 Card with Dual QSFP Ports.....	16
Figure 2: Representative LFF OCP NIC 3.0 Card with Dual QSFP Ports and on-board DRAM	17
Figure 3: SFF and LFF Block Diagrams (not to scale)	1918
Figure 4: Primary Connector (4C+) and Secondary Connector (4C) (LFF) OCP NIC 3.0 Cards	2522
Figure 5: Primary Connector (4C+) Only (LFF) OCP NIC 3.0 Cards	2623
Figure 6: Primary Connector (4C+) with 4C and 2C (SFF) OCP NIC 3.0 Cards	2723
Figure 7: SFF NIC Configuration Views	2925
Figure 8: SFF NIC Line Side 3D Views	3126
Figure 9: SFF NIC Chassis Mounted 3D Views	3327
Figure 10: LFF NIC Configuration Views	3629
Figure 11: LFF NIC Line Side 3D Views	3730
Figure 12: LFF NIC Chassis Mounted 3D Views	3831
Figure 13: PBA Exploded Views (SFF and LFF)	4033
Figure 14: Faceplate Assembly Exploded Views (SFF and LFF)	4134
Figure 15: SFF Generic I/O Faceplate with Pulltab Version (2D View)	4336
Figure 16: SFF Generic I/O Faceplate – Ejector Version (2D View)	4336
Figure 17: SFF Generic I/O Faceplate – Internal Lock Version (2D View)	4537
Figure 18: LFF Generic I/O Faceplate – Ejector Version (2D View)	4537
Figure 19: SFF I/O Faceplate – Ejector Lever (2D View)	4738
Figure 20: LFF I/O Faceplate – Ejector Lever (2D View)	4738
Figure 21: Ejector Lock	4839
Figure 22: Ejector Bushing	4839
Figure 23: Wave Washer	4940
Figure 24: SFF Keep Out Zone – Top View	5041
Figure 25: SFF Keep Out Zone – Top View – Detail A	5241
Figure 26: SFF Keep Out Zone – Bottom View	5342
Figure 27: SFF Keep Out Zone – Side View	5442
Figure 28: SFF Keep Out Zone – Side View – Detail D	5643
Figure 29: LFF Keep Out Zone – Top View	5744
Figure 30: LFF Keep Out Zone – Top View – Detail A	6045
Figure 31: LFF Keep Out Zone – Bottom View	6045
Figure 32: LFF Keep Out Zone – Side View	6246
Figure 33: LFF Keep Out Zone – Side View – Detail D	6346
Figure 34: SFF Bottom Side Insulator (3D View)	6447
Figure 35: SFF Bottom Side Insulator (Top and Side View)	6447
Figure 36: SFF Bottom Side Insulator (alternate) (Top and Side View)	6648
Figure 37: LFF Bottom Side Insulator (3D View)	6748
Figure 38: LFF Bottom Side Insulator (Top and Side View)	6849
Figure 39: LFF Bottom Side Insulator (alternate) (Top and Side View)	7150
Figure 40: SFF OCP NIC 3.0 Card with Pull Tab CTF Dimensions (Top View)	7251
Figure 41: SFF OCP NIC 3.0 Card with Pull Tab CTF Dimensions (Front View)	7352
Figure 42: SFF OCP NIC 3.0 Card with Pull Tab CTF Dimensions (Side View)	7352
Figure 43: SFF OCP NIC 3.0 Card with Ejector CTF Dimensions (Top View)	7453
Figure 44: SFF OCP NIC 3.0 Card with Ejector CTF Dimensions (Front View)	7453
Figure 45: SFF OCP NIC 3.0 Card with Ejector CTF Dimensions (Side View)	7453
Figure 46: SFF Baseboard Chassis CTF Dimensions (Rear View)	7554
Figure 47: SFF Baseboard Chassis to Card Thumb Screw CTF Dimensions (Side View)	7554
Figure 48: SFF Baseboard Chassis to Ejector lever Card CTF Dimensions (Side View)	7655
Figure 49: SFF Baseboard Chassis CTF Dimensions (Rear Rail Guide View)	7655
Figure 50: SFF Baseboard Chassis CTF Dimensions (Rail Guide Detail) – Detail C	7655
Figure 51: LFF OCP NIC 3.0 Card with Ejector CTF Dimensions (Top View)	7756
Figure 52: LFF OCP NIC 3.0 Card with Ejector CTF Dimensions (Front View)	7756

Figure 53: LFF OCP NIC 3.0 Card with Ejector CTF Dimensions (Side View)	7857
Figure 54: LFF Baseboard Chassis CTF Dimensions (Rear View)	7857
Figure 55: LFF Baseboard Chassis CTF Dimensions (Side View)	7958
Figure 56: LFF Baseboard Chassis CTF Dimensions (Rail Guide View)	7958
Figure 57: LFF Baseboard Chassis CTF Dimensions (Rail Guide – Detail C)	7958
Figure 58: SFF Label Area Example	8059
Figure 59: MAC Address Label Example 1 – Quad Port with Single Host, Single Managed Controller	8261
Figure 60: MAC Address Label Example 2 – Octal Port with Single Host, Dual Managed Controller	8462
Figure 61: MAC Address Label Example 3 – Quad Port with Dual Hosts, Dual Managed Controllers	8462
Figure 62: MAC Address Label Example 4 – Single Port with Quad Host, Single Managed Controller	8663
Figure 63: SFF Primary Connector Gold Finger Dimensions – x16 – Top Side (“B” Pins)	8865
Figure 64: LFF Gold Finger Dimensions – x32 – Top Side (“B” Pins)	8966
Figure 65: LFF Gold Finger Dimensions – x32 – Bottom Side (“A” Pins)	8966
Figure 66: 168-pin Base Board Primary Connector – Right Angle	9370
Figure 67: 140-pin Base Board Secondary Connector – Right Angle	9471
Figure 68: OCP NIC 3.0 Card and Host Offset for Right Angle Connectors	9471
Figure 69: 168-pin Base Board Primary Connector – Straddle Mount	9572
Figure 70: 140-pin Base Board Secondary Connector – Straddle Mount	9572
Figure 71: OCP NIC 3.0 Card and Baseboard PCB Thickness Options for Straddle Mount Connectors	9673
Figure 72: 0 mm Offset (Coplanar) for 0.062” Thick Baseboards	9673
Figure 73: 0.3 mm Offset for 0.076” Thick Baseboards	9774
Figure 74: Primary and Secondary Connector Locations for LFF Support with Right Angle Connectors	9774
Figure 75: Primary and Secondary Connector Locations for LFF Support with Straddle Mount Connectors	9774
Figure 76: PCIe Present and Bifurcation Control Pins (Baseboard Controlled BIF[0:2]#)	10986
Figure 77: PCIe Present and Bifurcation Control Pins (Static BIF[0:2]#)	10986
Figure 78: Example SMBus Connections	11188
Figure 79: NC-SI over RBT Connection Example – Single Primary Connector	11693
Figure 80: NC-SI over RBT Connection Example – Dual Primary Connectors	11794
Figure 81: Example Scan Chain Timing Diagram	11996
Figure 82: Scan Chain Connection Example	124101
Figure 83: Example Power Supply Topology	128105
Figure 84: USB 2.0 Connection Example – Basic Connectivity	129106
Figure 85: USB 2.0 Connection Example – USB-Serial / USB-JTAG Connectivity	129106
Figure 86: UART Connection Example	131108
Figure 87: Single Host (1 x16) and 1 x16 OCP NIC 3.0 Card (Single Controller)	139114
Figure 88: Single Host (2 x8) and 2 x8 OCP NIC 3.0 Card (Dual Controllers)	140115
Figure 89: Quad Hosts (4 x4) and 4 x4 OCP NIC 3.0 Card (Single Controller)	141116
Figure 90: Quad Hosts (4 x4) and 4 x4 OCP NIC 3.0 Card (Quad Controllers)	142117
Figure 91: Single Host with no Bifurcation (1 x16) and 2 x8 OCP NIC 3.0 Card (Dual Controllers)	143118
Figure 92: SFF PCIe REFCLK Mapping – Single Host – 1, 2 and 4 links	146120
Figure 93: SFF PCIe REFCLK Mapping – Dual Host – 2 and 4 links	147121
Figure 94: SFF PCIe REFCLK Mapping – Quad Host – 4 Links	148122
Figure 95: LFF PCIe REFCLK Mapping – Single Host – 1, 2 and 4 links	149123
Figure 96: LFF PCIe REFCLK Mapping – Dual Host – 2 and 4 links	150124
Figure 97: LFF PCIe REFCLK Mapping – Quad Host – 4 Links	151125
Figure 98: Port and LED Ordering – Example SFF Link/Activity and Speed LED Placement	166128
Figure 99: Baseboard Power States	167129
Figure 100: Power-Up Sequencing	171133
Figure 101: Power-Down Sequencing	174134
Figure 102: PCIe Load Board Test Fixture for OCP NIC 3.0 SFF	194150
Figure 103: PCIe Base Board Test Fixture for OCP NIC 3.0 SFF	195151
Figure 104: Airflow Direction for Hot Aisle Cooling (SFF and LFF)	196152
Figure 105: Airflow Direction for Cold Aisle Cooling (SFF and LFF)	197153
Figure 106: ASIC Supportable Power for Hot Aisle Cooling – SFF	198154
Figure 107: OCP NIC 3.0 SFF Reference Design and CFD Geometry	199155
Figure 108: Server System Airflow Capability – SFF Card Hot Aisle Cooling	200156
Figure 109: ASIC Supportable Power for Hot Aisle Cooling – LFF Card	201157
Figure 110: OCP NIC 3.0 LFF Reference Design and CFD Geometry	201157

Figure 111: Server System Airflow Capability – LFF Card Hot Aisle Cooling	203159
Figure 112: ASIC Supportable Power for Cold Aisle Cooling – SFF Card	204160
Figure 113: Server System Airflow Capability – SFF Cold Aisle Cooling.....	204160
Figure 114: ASIC Supportable Power Comparison – SFF Card	205161
Figure 115: ASIC Supportable Power for Cold Aisle Cooling – LFF Card	206162
Figure 116: Server System Airflow Capability – LFF Cold Aisle Cooling.....	207163
Figure 117: ASIC Supportable Power Comparison – LFF Card.....	207163
Figure 118: SFF Thermal Test Fixture Preliminary Design	209165
Figure 119: SFF Thermal Test Fixture Preliminary Design – Cover Removed	210166
Figure 120: SFF Card Thermal Test Fixture PCB	210166
Figure 121: LFF Card Thermal Test Fixture Design	211167
Figure 122: LFF Card Thermal Test Fixture Design – Cover Removed	212167
Figure 123: LFF Card Thermal Test Fixture PCB.....	212167
Figure 124: Thermal Test Fixture Airflow Direction	213169
Figure 125: SFF Fixture, Hot Aisle Flow - Candlestick Air Velocity vs. Volume Flow	214170
Figure 126: LFF Fixture, Hot Aisle Flow - Candlestick Air Velocity vs. Volume Flow.....	214170
Figure 127: Dye and Pull Type Locations	218174
Figure 128: Dye Coverage Percentage.....	218174

List of Tables

Table 1: Acknowledgements – By Company	11
Table 2: Acronyms	14
Table 3: OCP 3.0 Form Factor Dimensions	2049
Table 4: Baseboard to OCP NIC Form Factor Compatibility Chart	2049
Table 5: Example Non-NIC Use Cases	2224
Table 6: OCP NIC 3.0 Card Definitions	2824
Table 7: OCP NIC 3.0 Line Side I/O Implementations	3922
Table 8: Bill of Materials for the SFF and LFF Faceplate Assemblies	4235
Table 9: CTF Default Tolerances (SFF and LFF OCP NIC 3.0)	7254
Table 10: MAC Address Label Example 1 – Quad Port with Single Host, Single Managed Controller	8264
Table 11: MAC Address Label Example 2 – Octal Port with Single Host, Dual Managed Controller	8264
Table 12: MAC Address Label Example 3 – Quad Port with Dual Hosts, Dual Managed Controller	8462
Table 13: MAC Address Label Example 4 – Single Port with Quad Host, Single Managed Controller	8663
Table 14: NIC Implementation Examples and 3D CAD	8764
Table 15: Contact Mating Positions for the Primary Connector	8966
Table 16: Contact Mating Positions for the Secondary Connector	9168
Table 17: Right Angle Connector Options	9370
Table 18: Straddle Mount Connector Options	9474
Table 19: Primary Connector Pin Definition (x16) (4C+)	9875
Table 20: Secondary Connector Pin Definition (x16) (4C)	10077
Table 21: Pin Descriptions – PCIe	10178
Table 22: Pin Descriptions – PCIe Present and Bifurcation Control Pins	10784
Table 23: Pin Descriptions – SMBus	11087
Table 24: Pin Descriptions – NC-SI over RBT	11188
Table 25: Pin Descriptions – Scan Chain	11895
Table 26: Pin Descriptions – Scan Chain DATA_OUT Bit Definition	12097
Table 27: Pin Descriptions – Scan Chain DATA_IN Bit Definition	12197
Table 28: Pin Descriptions – Power	125402
Table 29: Pin Descriptions – USB 2.0 – Primary Connector only	128405
Table 30: Pin Descriptions – UART – Secondary Connector Only	130407
Table 31: Pin Descriptions – RFU[1:4]	132409
Table 32: PCIe Bifurcation Decoder for x32, x16, x8, x4, x2 and x1 Card Widths	135412
Table 33: PCIe REFCLK and PERST Associations	144419
Table 34: SFF PCIe Link / REFCLKn / PERSTn mapping for 1, 2 and 4 Links	144419
Table 35: LFF PCIe Link / REFCLKn / PERSTn mapping for 1, 2, 4 and 8 Links	144419
Table 36: OCP NIC 3.0 Card LED Configuration with Two Physical LEDs per Port	165427
Table 37: Power States	168430
Table 38: Baseboard Power Supply Rail Requirements – Slot Power Envelopes	169431
Table 39: Power Sequencing Parameters	176434
Table 40: Digital I/O DC specifications	177435
Table 41: Digital I/O AC specifications	177435
Table 42: OCP NIC 3.0 Management Implementation Definitions	178436
Table 43: Sideband Management Interface and Transport Requirements	178436
Table 44: NC-SI Traffic Requirements	179437
Table 45: MC MAC Address Provisioning Requirements	179437
Table 46: Temperature Reporting Requirements	181439
Table 47: Power Consumption Reporting Requirements	183440
Table 48: Pluggable Module Status Reporting Requirements	183441
Table 49: Management and Pre-OS Firmware Inventory and Update Requirements	184441
Table 50: Slot_ID[1:0] to Package ID[2:0] Mapping	186443
Table 51: FRU EEPROM Address Map	188444
Table 52: FRU EEPROM Record – OEM Record 0xC0, Offset 0x00	188445
Table 53: PCIe Electrical Budgets	193449
Table 54: PCIe Test Fixtures for OCP NIC 3.0	194450
Table 55: Hot Aisle Air Temperature Boundary Conditions	197453
Table 56: Hot Aisle Airflow Boundary Conditions	197453
Table 57: Cold Aisle Air Temperature Boundary Conditions	197453

Open Compute Project • OCP NIC 3.0

Rev [0.840-83](#)

Table 58: Cold Aisle Airflow Boundary Conditions.....	198154
Table 59: Reference OCP NIC 3.0 SFF Card Geometry.....	199155
Table 60: Reference OCP NIC 3.0 LFF Card Geometry.....	202158
Table 61: Hot Aisle Card Cooling Tier Definitions (LFM).....	215171
Table 62: Cold Aisle Card Cooling Tier Definitions (LFM).....	216172
Table 63: Random Vibration Testing 1.88 G _{RMS} Profile.....	217173
Table 64: FCC Class A Radiated and Conducted Emissions Requirements Based on Geographical Location.....	220176
Table 65: Safety Requirements	221177
Table 66: Immunity (ESD) Requirements.....	221177

1 Overview

1.1 License

As of January 23rd, 2018, the following persons or entities have made this Specification available under the Open Compute Project Hardware License (Permissive) Version 1.0 (OCPHL-P)

- OCP NIC Subgroup

An electronic copy of the OCPHL-P is available at:

<http://www.opencompute.org/assets/download/01-Contribution-Licenses/OCPHL-Permissive-v1.0.pdf>

Your use of this Specification may be subject to other third party rights. THIS SPECIFICATION IS PROVIDED "AS IS." The contributors expressly disclaim any warranties (express, implied, or otherwise), including implied warranties of merchantability, non-infringement, fitness for a particular purpose, or title, related to the Specification. The Specification implementer and user assume the entire risk as to implementing or otherwise using the Specification. IN NO EVENT WILL ANY PARTY BE LIABLE TO ANY OTHER PARTY FOR LOST PROFITS OR ANY FORM OF INDIRECT, SPECIAL, INCIDENTAL, OR CONSEQUENTIAL DAMAGES OF ANY CHARACTER FROM ANY CAUSES OF ACTION OF ANY KIND WITH RESPECT TO THIS SPECIFICATION OR ITS GOVERNING AGREEMENT, WHETHER BASED ON BREACH OF CONTRACT, TORT (INCLUDING NEGLIGENCE), OR OTHERWISE, AND WHETHER OR NOT THE OTHER PARTY HAS BEEN ADVISED OF THE POSSIBILITY OF SUCH DAMAGE.

1.2 Acknowledgements

The OCP NIC 3.0 specification was created under a collaboration from many OCP member companies, and facilitated by the OCP NIC Subgroup under the OCP Server Workgroup.

The OCP NIC Subgroup would like to acknowledge the following member companies for their contributions to the OCP NIC 3.0 specification:

Table 1: Acknowledgements – By Company

Amphenol Corporation	Keysight Technologies
Broadcom Limited	Lenovo Group Ltd
Cavium, Inc.	Mellanox Technologies, Ltd
Dell, Inc.	Netronome Systems, Inc.
Facebook, Inc.	Quanta Computer Inc.
Hewlett Packard Enterprise Company	TE Connectivity Corporation
Intel Corporation	University of New Hampshire InterOperability Lab

1.3 References

- [DMTF Standard. DSP0222, Network Controller Sideband Interface \(NC-SI\) Specification. Distributed Management Task Force \(DMTF\), Rev 1.1.0, September 23rd, 2015.](#)
- [DMTF Standard. DSP0222, Network Controller Sideband Interface \(NC-SI\) Specification. Distributed Management Task Force \(DMTF\), Rev 1.2.0, Work-In-Progress.](#)
- [DMTF Standard. DSP0236, Management Component Transport Protocol \(MCTP\) Base Specification. Distributed Management Task Force \(DMTF\), Rev 1.3.0, November 24th, 2016.](#)
- [DMTF Standard. DSP0237, Management Component Transport Protocol \(MCTP\) SMBus/I2C Transport Binding Specification. Distributed Management Task Force \(DMTF\), Rev 1.1.0, May 21st, 2017.](#)
- [DMTF Standard. DSP0238, Management Component Transport Protocol \(MCTP\) PCIe VDM Transport Binding Specification. Distributed Management Task Force \(DMTF\), Rev 1.0.2, December 7th, 2014.](#)
- [DMTF Standard. DSP0239, MCTP IDs and Codes Specification. Distributed Management Task Force \(DMTF\), Rev 1.5.0, December 17th, 2017.](#)
- [DMTF Standard. DSP0240, Platform Level Data Model \(PLDM\) Base Specification. Distributed Management Task Force \(DMTF\), Rev 1.0.0, April 23rd, 2009.](#)
- [DMTF Standard. DSP0240, Platform Level Data Model \(PLDM\) over MCTP Binding Specification. Distributed Management Task Force \(DMTF\), Rev 1.0.0, April 23rd, 2009.](#)
- [DMTF Standard. DSP0245, Platform Level Data Model \(PLDM\) IDs and Codes Specification. Distributed Management Task Force \(DMTF\), Rev 1.2.0, November 24th, 2016.](#)
- [DMTF Standard. DSP0248, Platform Level Data Model \(PLDM\) for Platform Monitoring and Control Specification. Distributed Management Task Force \(DMTF\), Rev 1.1.1, January 10th, 2017.](#)
- [DMTF Standard. DSP0249, Platform Level Data Model \(PLDM\) State Sets Specification. Distributed Management Task Force \(DMTF\), Rev 1.0.0, March 16th, 2009.](#)
- [DMTF Standard. DSP0261, NC-SI over MCTP Binding Specification. Distributed Management Task Force \(DMTF\), Rev 1.2.0, August 26th, 2017.](#)
- [EDSFF. Enterprise and Datacenter SSD Form Factor Connector Specification. Enterprise and Datacenter SSD Form Factor Working Group, Rev 0.9 \(draft\), August 2nd 2017.](#)
- [IPC. IPC-TM-650 Test Methods Manual number 2.4.53. Dye and Pull Test Method \(Formerly Known as Dye and Pry\), Association Connecting Electronics Industries, August 2017.](#)
- [IPMI Platform Management FRU Information Storage Definition, v1.0 Document Revision 1.3, March 24th, 2015.](#)
- [National Institute of Standards and Technology \(NIST\). Special Publication 800-193, Platform Firmware Resiliency Guidelines, draft, May 2017.](#)
- [NXP Semiconductors. I²C-bus specification and user manual. NXP Semiconductors, Rev 6, April 4th, 2014.](#)
- [Open Compute Project. OCP NIC Subgroup. Online. <http://www.opencompute.org/wiki/Server/Mezz>](#)
- [PCI-SIG[®] Base Specification. PCI Express[®] Base Specification, Revision 3.0 December 7th, 2015.](#)
- [PCI-SIG[®] Base Specification. PCI Express[®] Base Specification, Revision 4.0 Version 1.0, October 5th, 2017.](#)

- [PCI-SIG® e-CEM Specification. PCI Express® Card Electromechanical Specification, Revision 3.0, July 21st, 2013.](#)
- [PCI-SIG® e-CEM Specification. PCI Express® Card Electromechanical Specification, Revision 4.0 \(draft\).](#)
- [SMBus Management Interface Forum. System Management Bus \(SMBus\) Specification. System Management Interface Forum, Inc, Version 2.0, August 3rd, 2000.](#)
- [SNIA. SFF-TA-1002, Specification for Protocol Agnostic Multi-Lane High Speed Connector. SNIA SFF TWG Technology Affiliate, Rev 1.1 draft, January 18th, 2018.](#)
- [UEFI Specification Version 2.5, \[http://www.uefi.org/sites/default/files/resources/UEFI%202_5.pdf\]\(http://www.uefi.org/sites/default/files/resources/UEFI%202_5.pdf\), April 2015.](#)
- [USB Implementers Forum. Universal Serial Bus Specification, Revision 2.0, April 27th, 2000.](#)

1.3.1 Trademarks

Names and brands may be claimed as trademarks by their respective companies.

[PCIe® and PCI Express® are the registered trademarks of PCI-SIG.](#)

1.4 Acronyms

For the purposes of the OCP NIC 3.0 specification, the following acronyms apply:

Table 2: Acronyms

Acronym	Definition
AIC	Add-in Card
ASIC	Application Specific Integrated Circuit
BGA	Ball Grid Array
BMC	Baseboard Management Controller
BOM	Bill of Materials
CAD	Computer Aided Design
CBB	Compliance Base Board
CEM	Card Electromechanical
CFD	Computational Fluid Dynamics
CFM	Cubic Feet per Minute
CLB	Compliance Load Board
CTD	Chain of Trust for Detection
CTF	Critical to Function
CTU	Chain of Trust for Update
DMTF	Distributed Management Task Force
DRAM	Dynamic Random Access Memory
EDSFF	Enterprise and Datacenter SSD Form Factor
EMI	Electro Magnetic Interference
ESD	Electrostatic Discharge
EU	European Union
FCC	Federal Communications Commission
FRU	Field Replaceable Unit
I/O	Input / Output
I2C	Inter-Integrated Circuit - two wire serial protocol
IEC	International Electrotechnical Commission
IPC	Institute for Printed Circuits
IPMI	Intelligent Platform Management Interface
ISO	International Organization for Standardization
LED	Light Emitting Diode
LFF	Large Form Factor
LFM	Linear Feet per Minute
MAC	Media Access Control
MC	Management Controller
MCTP	Management Component Transport Protocol
ME	Management Entity
NC	No Connect
NC-SI	Network Controller Sideband Interface
NEBS	Network Equipment Building-System
NIC	Network Interface Card
OCP	Open Compute Project
ODM	Original Design Manufacturer

OEM	Original Equipment Manufacturer
PBA	Printed Board Assembly
PCB	Printed Circuit Board
PCI™	Peripheral Component Interconnect
PCIe®	PCI Express®
PDR	Platform Descriptor Record
PLDM	Platform Level Data Model
QSFP	Quad Small Form Factor Pluggable
QZ	Quiet Zone
RA	Right Angle
RBT	RMII Based Transport
REACH	Registration, Evaluation, Authorization and Restriction of Chemicals
RFU	Reserved Future Use
RJ45	Registered Jack 45 (IEC 60603-7 8P8C connector)
RoHS	Restriction of Hazardous Substances Directive
RSVD	Reserved
RTU	Root of Trust for Update
SFF	Small Form Factor
SFP	Small Form Factor Pluggable
SMBus	System Management Bus
SMT	Surface Mount Technology
TBD	To be Determined
TDP	Thermal Design Power
UART	Universal Asynchronous Receiver-Transmitter
UUID	Universally Unique Identifier
UEFI	Unified Extensible Firmware Interface
USB	Universal Serial Bus
VDM	Vendor Defined Messages
WEEE	Waste Electrical and Electronic Equipment

1.31.5 Background

The OCP NIC 3.0 specification is a follow-on to the OCP Mezz 2.0 rev 1.00 design specification. The OCP NIC 3.0 specification supports two basic card sizes: Small Form Factor (SFF), and Large Form Factor (LFF). The SFF allows for up to 16 PCIe[®] lanes on the card edge while the LFF supports up to 32 PCIe lanes. Compared to the OCP Mezz Card 2.0 Design Specification, the updated OCP NIC 3.0 specification provides a broader solution space for the NIC and system vendors to support the following use case scenarios:

- NICs with a higher Thermal Design Power (TDP)
- Power delivery supports up to 80_W to a single connector (SFF) card, and up to 150_W to a dual connector (LFF) card
 - Note: Baseboard vendors need to evaluate if there is sufficient airflow to thermally cool the OCP NIC 3.0 card. Refer to Section 6 for additional details.
- Supports up to PCIe Gen 4 (16 GT/s) on the baseboard and OCP NIC 3.0 card
 - Connector is electrically compatible with PCIe Gen 5 (32 GT/s)
- Support for up to 32 lanes of PCIe per OCP NIC 3.0 card
- Support for single host, multi-root complex, and multi-host environments
- Supports a greater board area for more complex OCP NIC 3.0 card designs
- Support for Smart NIC implementations with on-board DRAM and accelerators
- Simplification of FRU installation and removal while reducing overall down time

A representative SFF OCP NIC 3.0 card is shown in Figure 1 and a representative LFF is shown in Figure 2.

Figure 1: Representative SFF OCP NIC 3.0 Card with Dual QSFP Ports

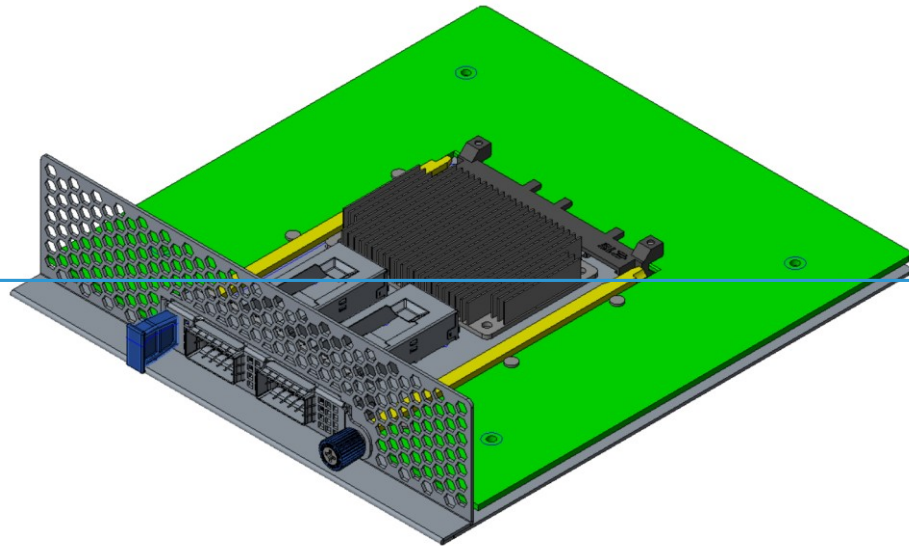
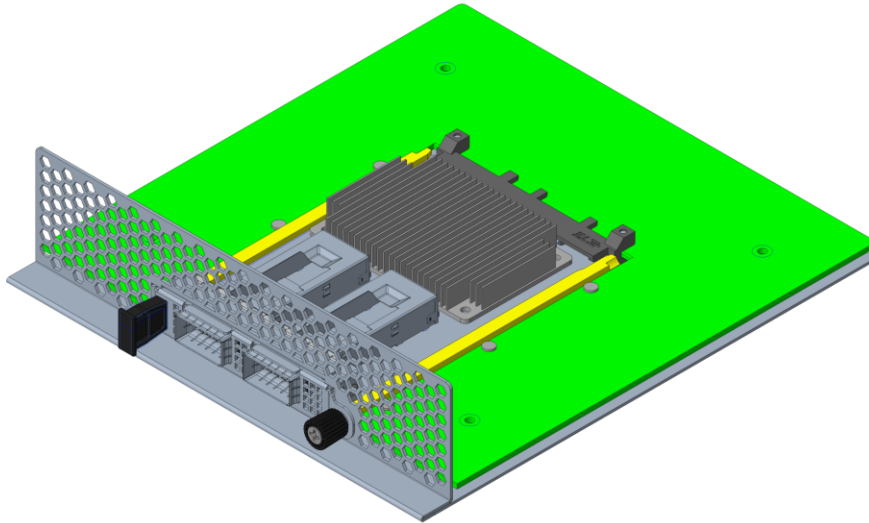
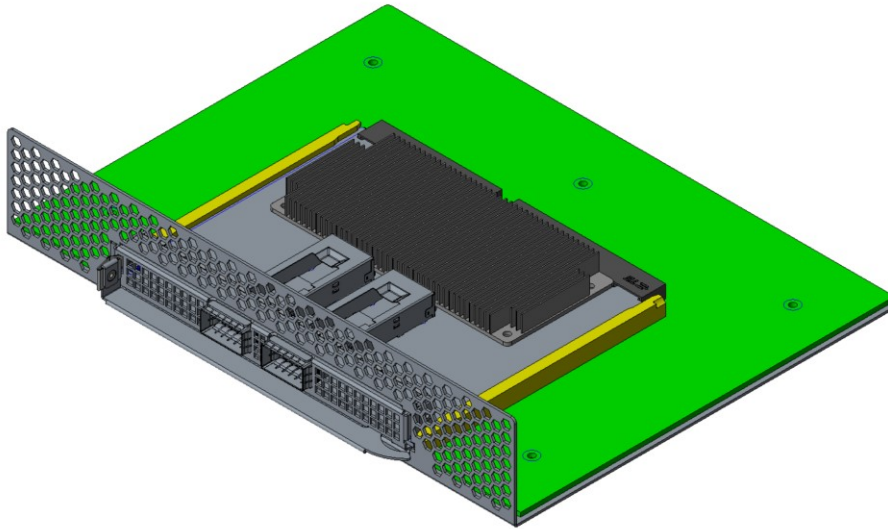

Figure 2: Representative LFF OCP NIC 3.0 Card with Dual QSFP Ports and on-board DRAM



In order to achieve the features outlined in this specification, OCP NIC 3.0 compliant cards are not backwards compatible with OCP Mezz 2.0 cards.

This specification is created under OCP Server workgroup – OCP NIC subgroup. An electronic copy of this specification can be found on the Open Compute Project and the OCP Marketplace websites:

http://www.opencompute.org/wiki/Server/Mezz#Specifications_and_Designs

<https://www.opencompute.org/contributions?query=OCP%20NIC%203.0>

1.4.1.6 Overview

1.4.1.6.1 Mechanical Form factor-~~Factor overview~~Overview

The OCP NIC 3.0 specification defines a third generation mechanical form factor that allows for interoperability between compliant baseboards and OCP NIC 3.0 cards.

OCP NIC 3.0 cards have two form factors – SFF and LFF. These cards are shown in Figure 3 below. The components shown in the figures are for illustrative purposes. The SFF ~~card has~~uses one connector (Primary Connector) on the baseboard. The LFF ~~card has~~uses one or two connectors (Primary Connector only or both the Primary and Secondary Connectors) on the baseboard.

Both the Primary and Secondary Connectors and card edge gold fingers are defined in and compliant to SFF-TA-1002. The Primary Connector is the “4C+” variant, the Secondary Connector is the “4C” version. On the OCP NIC 3.0 card side, the card edge is implemented with gold fingers. The SFF gold finger area only occupies the Primary Connector area for up to 16 PCIe lanes. The LFF gold finger area may occupy both the Primary and Secondary Connectors for up to 32 PCIe lanes, or optionally just the Primary Connector for up to 16 PCIe lane implementations.

Figure 3: ~~Small and Large Form Factor~~SFF and LFF Block Diagrams (not to scale)

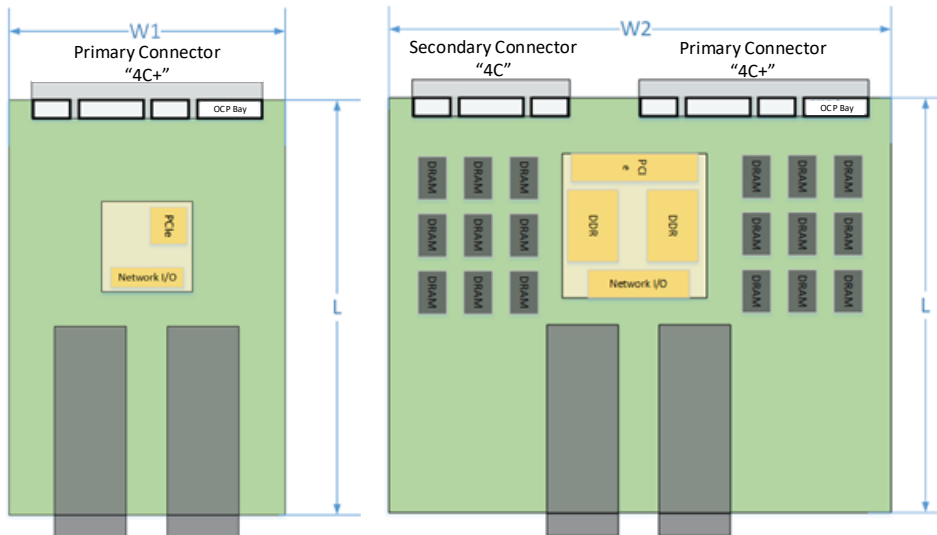

The two form factor dimensions are shown in [Table 3Table-2](#).

[Table 32: OCP 3.0 Form Factor Dimensions](#)

Form Factor	Width	Depth	Primary Connector	Secondary Connector	Typical Use Case
SFF	W1 = 76 mm	L = 115 mm	“4C+” 168 pins	N/A	Low profile and NIC with a similar profile as an OCP NIC 2.0 card; up to 16 PCIe lanes.
LFF	W2 = 139 mm	L = 115 mm	“4C+” 168 pins	“4C” 140 pins	Larger PCB width to support additional NICs; up to 32 PCIe lanes.

The OCP NIC 3.0 design allows downward compatibility between the two card sizes. [Table 4Table-3](#) shows the compatibility between the baseboard and NIC combinations. A SFF baseboard slot may only accept a SFF sized NIC. A LFF baseboard slot may accept a SFF or LFF NIC.

[Table 43: Baseboard to OCP NIC Form factor-Factor Compatibility Chart](#)

Baseboard Slot Size	NIC Size / Supported PCIe Width	
	SFF	LFF
SFF	Up to 16 PCIe lanes	Not Supported
LFF	Up to 16 PCIe lanes	Up to 32 PCIe lanes

There are two baseboard connector mounting options available for system designers: straddle mount and right angle (RA). The straddle mount connector option allows the OCP NIC and baseboard to exist in a co-planer position. To achieve this, a cutout exists on the baseboard and is defined in this specification. Alternatively, the right angle option allows the OCP NIC to be installed on top of the baseboard. A baseboard cutout is not required for the right angle connector. The right angle option allows the baseboard to use this area for additional routing or backside component placement. The straddle mount and right angle connectors are shown in Section 3.2.

For both the baseboard and OCP NIC 3.0 card, this specification defines the component and routing keep out areas. Refer to Section 2.5 for details.

Both the straddle mount and right angle implementations shall accept the same OCP NIC 3.0 card and shall be supported in the baseboard chassis regardless of the baseboard connector selection (right angle or straddle mount) so long as the baseboard slot and OCP NIC 3.0 card sizes are a supported combination as shown in [Table 4Table-3](#).

This specification defines the form factor at the OCP NIC 3.0 card level, including the front panel, latching mechanism and card guide features.

More details about the card form-factor is shown in Section 2.

~~1.4.21.6.2~~ 1.4.21.6.2 ~~Electrical overview~~Overview

This specification defines the electrical interface between baseboard and the OCP NIC 3.0 card. The electrical interface is implemented with a right angle or straddle mount connector on baseboard and gold finger on the OCP NIC 3.0 card. As previously noted in the mechanical overview, each card may implement a Primary Connector or Primary + Secondary Connector. Cards using only the Primary Connector are suitable for both the ~~Small-SFF~~ and ~~Large form factors-LFF~~ and may support up to 16 lanes of PCIe. The Secondary Connector, when used in conjunction with the Primary Connector, allows ~~Large form factor-LFF~~ implementations and may support up to 32 lanes of PCIe.

~~1.4.21.6.2.1~~ 1.4.21.6.2.1 ~~Primary Connector~~

The Primary Connector provides all OCP specific management functions as well as up to 16 lanes of PCIe between the OCP NIC and the system motherboard.

Management Function Overview (OCP Bay):

- DMTF DSP0222 ~~4-4~~-compliant Network Controller Sideband Interface (NC-SI) RMIII Based Transport (RBT) Physical Interface
- Power management and status reporting
 - Power break for emergency power reduction
 - State change control
- Control / status serial bus
 - NIC-to-Host status
 - Port LED Link/Activity
 - Environmental Indicators
 - Host-to-NIC configuration Information
- Multi-host PCIe support signals (2x PCIe resets, 2x reference clocks)
 - The OCP bay provides PERST2#, PERST3#, REFCLK2 and REFCLK3. This enables support for up to four hosts when used in conjunction with PERST0#, PERST1#, REFCLK0 and REFCLK1 in the Primary 4C region.
- PCIe Wake signal

See Section 3.4 for a complete list of pin and function descriptions for the OCP Bay portion of the Primary Connector. The OCP Bay pins are prefixed with “OCP_” in the pin location column.

Interface Overview (4C Connector):

- 16x differential transmit/receive pairs
 - Up to PCIe Gen 4 (16 GT/s) support
 - Connector is electrically compatible with PCIe Gen 5 (32 GT/s)
- 2x 100 MHz differential reference clocks
- Control signals
 - 2x PCIe Resets
 - Link Bifurcation Control
 - Card power disable/enable
- SMBus 2.0
- USB 2.0 interface

- Power
 - +12V_EDGE
 - +3.3V_EDGE
 - Power distribution between the aux and main power domains is up to the baseboard vendor

See Section 3.4 for a complete list of pin and function descriptions for the 4C+ connector.

[1.4.2.21.6.2.2](#) Secondary Connector

The Secondary Connector provides an additional 16 lanes of PCIe and their respective control signals.

Interface Overview (4C Connector):

- 16x differential transmit/receive pairs
 - Up to PCIe Gen 4 (16 GT/s) support
 - Connector is electrically compatible with PCIe Gen 5 (32 GT/s)
- 2x 100 MHz differential reference clocks
- Control signals
 - 2x PCIe Resets
 - Link Bifurcation Control
 - Card power disable/enable
- SMBus 2.0
- UART (transmit and receive)
- Power
 - +12V_EDGE
 - +3.3V_EDGE
 - Power distribution between the aux and main power domains is up to the baseboard vendor

See Section 3.4 for a complete list of pin and function descriptions for the 4C connector.

[1.51.7](#) Non-NIC Use Cases

The OCP NIC 3.0 specification is mainly targeted for Network Interface Card applications. It is possible to use the same OCP NIC 3.0 card form-factor, baseboard interface and mechanical design to enable non-NIC use cases. These non-NIC use cases use the same baseboard/OCP NIC 3.0 card interface as defined in Section 3. The non-NIC use cases are not covered in the current revision of the OCP NIC 3.0 specification. Example non-NIC use cases implement various external I/O interfaces and are shown in [Table 5Table-4](#).

Table 54: Example Non-NIC Use Cases

Example Use Case	Card External I/O Interface(s)
PCIe Retimer Card	PCIe
Accelerator Card	N/A
NVMe Card	N/A
Storage HBA / RAID Card	TBD

1.61.1 References

- DMTF Standard. *DSP0222, Network Controller Sideband Interface (NC-SI) Specification*. Distributed Management Task Force (DMTF), Rev 1.1.0, September 23rd, 2015.
- DMTF Standard. *DSP0222, Network Controller Sideband Interface (NC-SI) Specification*. Distributed Management Task Force (DMTF), Rev 1.2.0, Work In Progress.
- DMTF Standard. *DSP0236, Management Component Transport Protocol (MCTP) Base Specification*. Distributed Management Task Force (DMTF), Rev 1.3.0, November 24th, 2016.
- DMTF Standard. *DSP0237, Management Component Transport Protocol (MCTP) SMBus/I2C Transport Binding Specification*. Distributed Management Task Force (DMTF), Rev 1.1.0, May 21st, 2017.
- DMTF Standard. *DSP0238, Management Component Transport Protocol (MCTP) PCIe-VDM Transport Binding Specification*. Distributed Management Task Force (DMTF), Rev 1.0.2, December 7th, 2014.
- DMTF Standard. *DSP0239, MCTP IDs and Codes Specification*. Distributed Management Task Force (DMTF), Rev 1.5.0, December 17th, 2017.
- DMTF Standard. *DSP0240, Platform Level Data Model (PLDM) Base Specification*. Distributed Management Task Force (DMTF), Rev 1.0.0, April 23rd, 2009.
- DMTF Standard. *DSP0240, Platform Level Data Model (PLDM) over MCTP Binding Specification*. Distributed Management Task Force (DMTF), Rev 1.0.0, April 23rd, 2009.
- DMTF Standard. *DSP0245, Platform Level Data Model (PLDM) IDs and Codes Specification*. Distributed Management Task Force (DMTF), Rev 1.2.0, November 24th, 2016.
- DMTF Standard. *DSP0248, Platform Level Data Model (PLDM) for Platform Monitoring and Control Specification*. Distributed Management Task Force (DMTF), Rev 1.1.1, January 10th, 2017.
- DMTF Standard. *DSP0249, Platform Level Data Model (PLDM) State Sets Specification*. Distributed Management Task Force (DMTF), Rev 1.0.0, March 16th, 2009.
- DMTF Standard. *DSP0261, NC-SI over MCTP Binding Specification*. Distributed Management Task Force (DMTF), Rev 1.2.0, August 26th, 2017.
- EDSFF. *Enterprise and Datacenter SSD Form Factor Connector Specification*. Enterprise and Datacenter SSD Form Factor Working Group, Rev 0.9 (draft), August 2nd, 2017.
- IPC. *IPC TM-650 Test Methods Manual number 2.4.53. Dye and Pull Test Method (Formerly Known as Dye and Pry)*, Association Connecting Electronics Industries, August 2017.
- IPMI Platform Management FRU Information Storage Definition, v1.0 Document Revision 1.3, March 24th, 2015.
- National Institute of Standards and Technology (NIST). *Special Publication 800-193, Platform Firmware Resiliency Guidelines*, draft, May 2017.
- NXP Semiconductors. *I²C bus specification and user manual*. NXP Semiconductors, Rev 6, April 4th, 2014.
- Open Compute Project. *OCP NIC Subgroup*. Online. <http://www.opencompute.org/wiki/Server/Mezz>
- PCIe Base Specification. *PCI Express Base Specification*, Revision 3.0 December 7th, 2015.
- PCIe Base Specification. *PCI Express Base Specification*, Revision 4.0 Version 1.0, October 5th, 2017.

- ~~PCIe CEM Specification. *PCI Express Card Electromechanical Specification, Revision 3.0*, July 21st, 2013.~~
- ~~PCIe CEM Specification. *PCI Express Card Electromechanical Specification, Revision 4.0 (draft)*.~~
- ~~SMBus Management Interface Forum. *System Management Bus (SMBus) Specification*. System Management Interface Forum, Inc, Version 2.0, August 3rd, 2000.~~
- ~~SNIA. SFF TA-1002, *Specification for Protocol Agnostic Multi-Lane High-Speed Connector*. SNIA-SFF TWG Technology Affiliate, Rev 1.1 draft, January 18th, 2018.~~
- ~~UEFI Specification Version 2.5, <http://www.uefi.org/sites/default/files/resources/UEFI%202.5.pdf>, April 2015.~~
- ~~USB Implementers Forum. *Universal Serial Bus Specification, Revision 2.0*, April 27th, 2000.~~

~~1.6.11.1.1~~ Trademarks

~~Names and brands may be claimed as trademarks by their respective companies.~~

2 Mechanical Card Form Factor

2.1 Form Factor Options

OCP NIC 3.0 provides two fundamental form factor options: a SFF (76_mm x 115_mm) and a LFF (139_mm x 115_mm).

These form factors support a Primary Connector and optionally, a Secondary Connector. The Primary Connector is defined to be a SFF-TA-1002 compliant 4C+ connector. The 4C+ connector is a 4C compliant implementation plus a 28-pin “OCP bay” for OCP NIC 3.0 specific pins. The Secondary Connector is the 4C connector as defined in SFF-TA-1002. The 4C specification supports up to 32 differential pairs for a x16 PCIe connection per connector. For host platforms, the 28-pin OCP bay is required for [all the Primary Connector implementations](#). ~~This is also mandatory for OCP NIC 3.0 cards.~~

The SFF uses the Primary 4C+ connector to provide up to a x16 PCIe interface to the host. The additional 28-pin OCP bay carries sideband management interfaces as well as OCP NIC 3.0 specific control signals for multi-host PCIe support. The SFF card provides sufficient faceplate area to accommodate up to 2x QSFP modules, 4x SFP modules, or 4x RJ-45 for BASE-T operation. The SFF supports up to 80_W of delivered power to the card edge. An example SFF is shown in Figure 1.

The LFF uses the Primary 4C+ connector to provide the same functionality as the SFF along with an additional Secondary 4C connector to provide up to a x32 PCIe interface. The LFF Card may utilize both the Primary and Secondary Connectors, or just the Primary Connector for lower PCIe lane count applications. ~~Table 6~~[Table 5](#) summarizes the LFF permutations. The LFF supports higher power envelopes and provides additional board area for more complex designs. The LFF supports up to 150_W of delivered power to the card edge across the two connectors. An example LFF is shown in Figure 2.

For LFF Cards, implementations may use both the Primary and Secondary Connector (as shown in Figure 4), or may use the Primary Connector only (as shown in Figure 5) for the card edge gold fingers.

Figure 4: Primary Connector (4C+) and Secondary Connector (4C) (LFF) OCP NIC 3.0 Cards

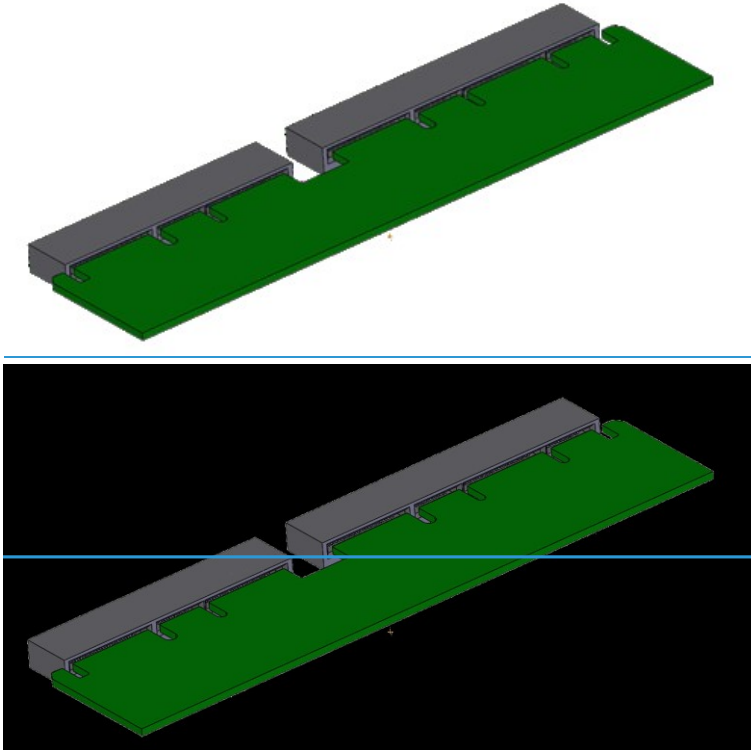
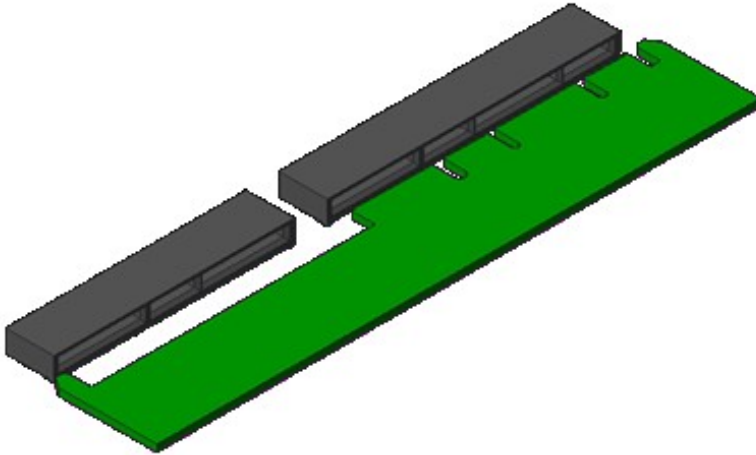
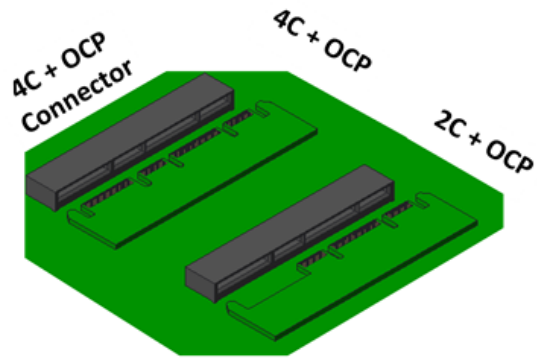

Figure 5: Primary Connector (4C+) Only (LFF) OCP NIC 3.0 Cards



For both form factors, an OCP NIC 3.0 card may optionally implement a subset of pins to support less than a x16 PCIe connection. This may be implemented using a 2C+ card edge per SFF-TA-1002. The baseboard Primary Connector shall use a 4C+ in all cases. Figure 6 illustrates the supported 4C+ and 2C+ card edge configurations on a 4C+ Primary Connector.

Figure 6: Primary Connector (4C+) with 4C and 2C (SFF) OCP NIC 3.0 Cards



[Table 6](#) [Table 5](#) summarizes the supported card form factors. [Small form factor](#) [SFF](#) cards support the Primary Connector and up to 16 PCIe lanes. [Large form factor](#) [LFF](#) cards support implementations with both the Primary and Secondary Connectors and up to 32 PCIe lanes, or a Primary Connector only implementation with up to 16 PCIe lanes.

Table 65: OCP NIC 3.0 Card Definitions

OCP NIC 3.0 Card Size and PCIe Lane Count	Baseboard Secondary Connector (4C)	Baseboard Primary Connector (4C+)	
	x16 PCIe	x16 PCIe	OCP Bay
Small-SFF (x8)	Not used with SFF 2C+ Card Edge	x8 (Lanes 7:0) PCIe	OCP Bay
Small-SFF (x16)	Not used with SFF 4C+ Card Edge	x16 (Lanes 15:0) PCIe	OCP Bay
Large-LFF (x8)	Not used with LFF 2C+ Card Edge	x8 (Lanes 7:0) PCIe	OCP Bay
Large-LFF (x16)	Not used with LFF 4C+ Card Edge	x16 (Lanes 15:0) PCIe	OCP Bay
Large-LFF (x32)	x16 (Lanes 31:16) PCIe	x16 (Lanes 15:0) PCIe	OCP Bay

2.1.1 ~~Small Form Factor (SFF)~~ Faceplate Configurations

The ~~small form factor (SFF)~~ configuration views are shown below. Three different faceplates are available for the SFF – a pull tab, ejector latch and an internal lock version are available. The same SFF OCP NIC 3.0 PBA assembly accepts all three faceplates types and may be interchanged depending on the end application. The drawings shown in Figure 7 below illustrate a representative front, side and top views of the SFF.

Where space is permitted on the faceplate, square vents sized to a maximum of 3.0 mm x 3.0 mm must be added to help optimize airflow while maintaining the integrity of the faceplate structure. EMI considerations should also be taken into account during the design process. Refer to the images shown in Figure 8 for example square vent configurations depending on the line side I/O connectors.

Depending on the OCP NIC 3.0 card implementation, I/O connectors may be placed anywhere within the allowable connector keep in regions as defined by the SFF PBA mechanical drawings and faceplate drawings of Section 2.5.1.

The OCP NIC 3.0 outline provides an optional feature to lock the card into the chassis. This is accomplished with two notches – one on each side of the card guide rail. A baseboard may choose to use one or both notches for the internal locking mechanism. Only one notch is required to hold the card in place. The OCP NIC 3.0 outline provides a notch location on both guide rails to provide flexible configurations to baseboard vendors. If the locking feature is implemented on the baseboard, the OCP NIC 3.0 card may only be inserted or removed after pressing on an internal locking mechanism. This retention notch is compatible with all chassis implementations. Please refer to the SFF dimensions in Section 2.5.1 for details. The internal locking mechanism is not available on LFF cards.

Note: The OCP NIC 3.0 card supplier shall add port identification on the faceplate assembly that meet their manufacturing and customer requirements.

All of the OCP NIC 3.0 CAD files are available for download and use on the OCP NIC 3.0 Wiki site: <http://www.opencompute.org/wiki/Server/Mezz>

Figure 7: SFF NIC Configuration Views

Small Form Factor (SFF) with Pull Tab

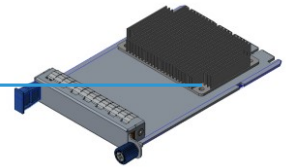
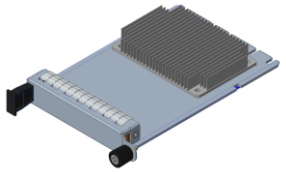

Small Form Factor (SFF) with Ejector Latch

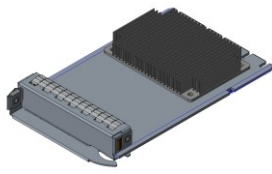

Small Form Factor (SFF) with Internal Lock

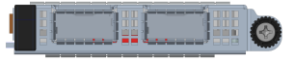
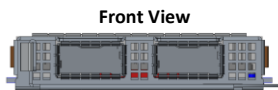
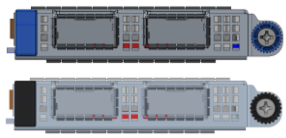
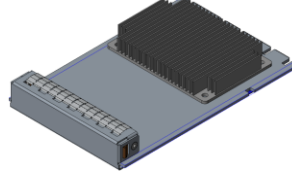

Side View



Top View

Open Compute Project • OCP NIC 3.0
Rev [0.840-83](#)

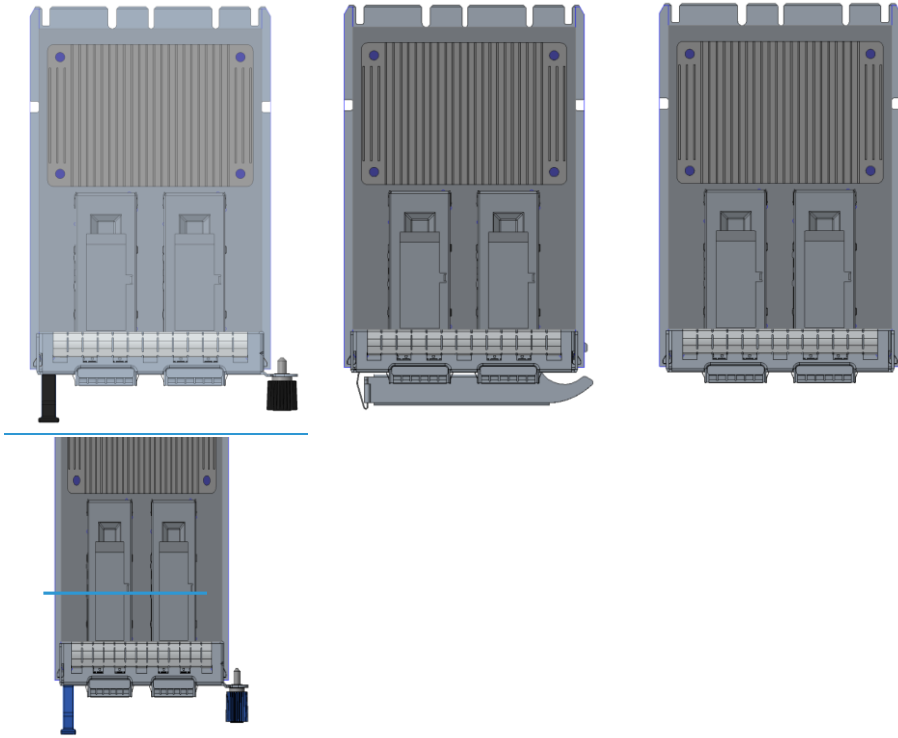
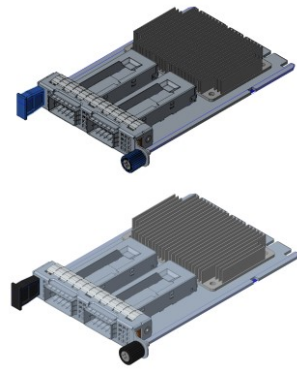

Figure 8 illustrates example SFF 3D views for the supported line side I/O implementations. The line side I/O implementations are discussed in Section 2.2.

Figure 8: SFF NIC Line Side 3D Views

Small-Form-Factor (SFF) with Pull Tab



Small-Form-Factor (SFF) with Ejector Latch

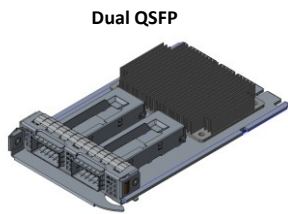

Small-Form-Factor (SFF) with Internal Lock

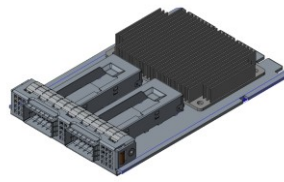

Dual QSFP

Quad SFP

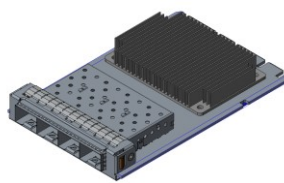
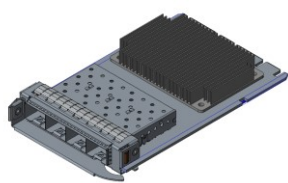
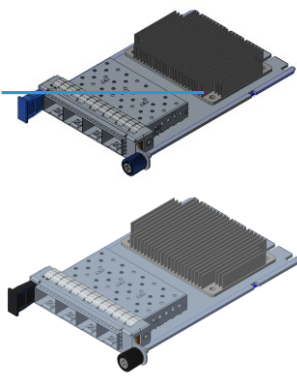

Quad RJ45

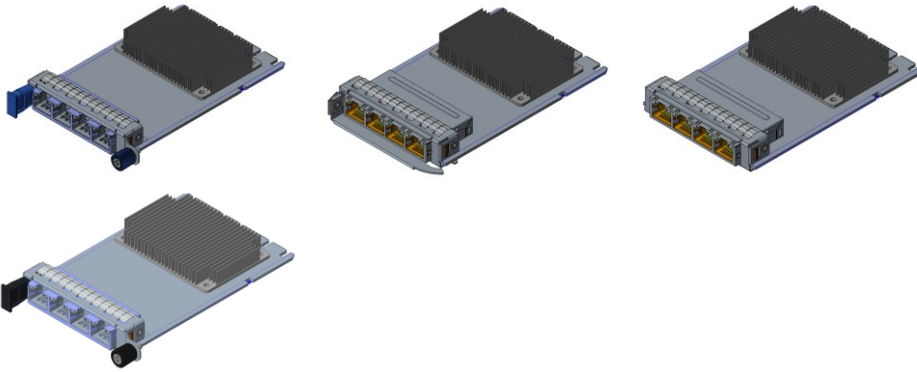

Figure 9 illustrates example SFF 3D views of the pull tab and ejector latch assemblies mounted in a chassis utilizing a straddle mount connector and a right angle connector. The baseboard connector options are discussed in Section 3.2. The SFF OCP NIC 3.0 card is identical for both chassis connector options.

As previously noted, the OCP NIC 3.0 card provides a notch on the rail edge for an internal locking mechanism to prevent card insertion and removal. The internal locking mechanism is an optional feature and is not shown in the views below.

Figure 9: SFF NIC Chassis Mounted 3D Views

~~Small Form Factor (SFF)~~ with Pull Tab

~~Small Form Factor (SFF)~~ with Ejector Latch

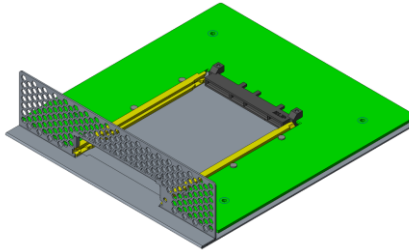
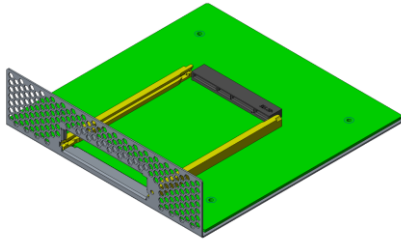

Right Angle vs Straddle Mount Chassis Configuration

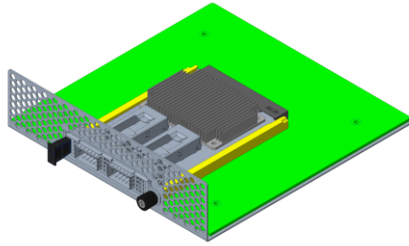
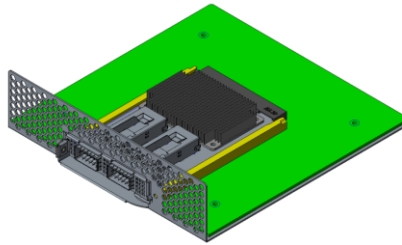
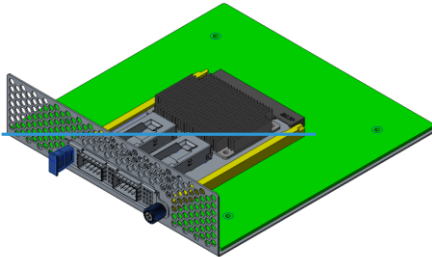

Right Angle Baseboard Connector

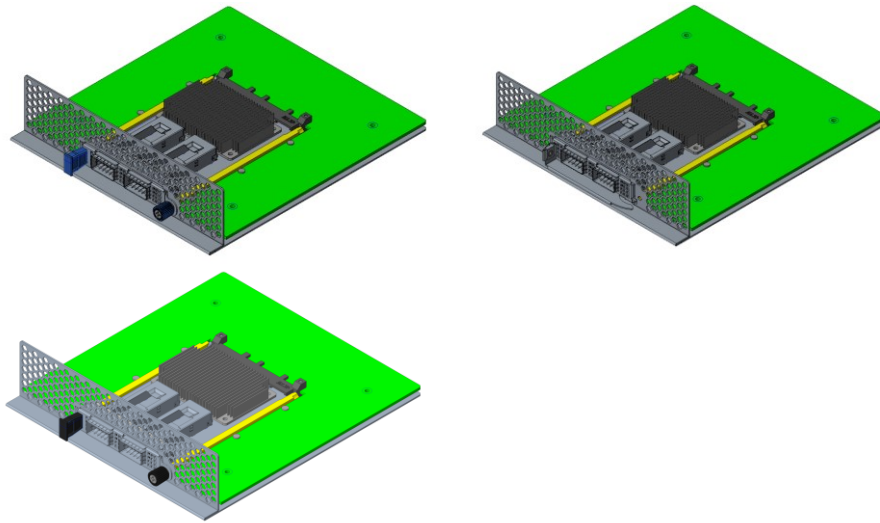

Straddle Mount Baseboard Connector

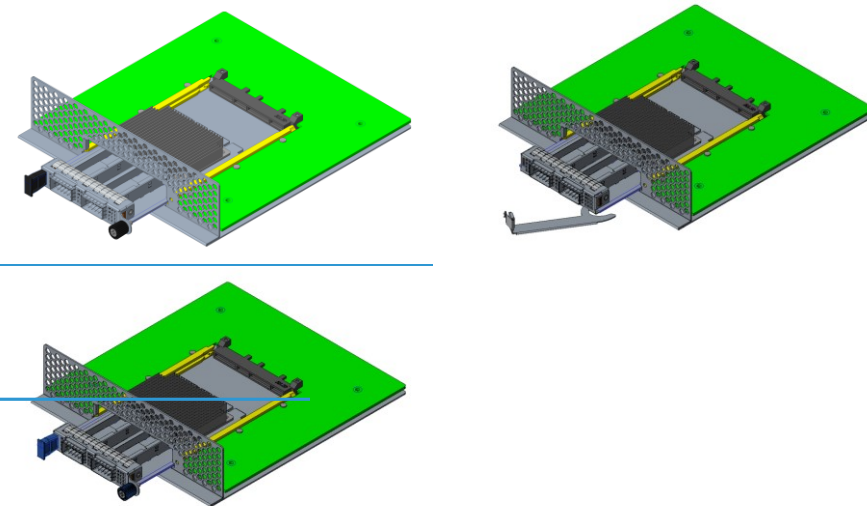

NIC Insertion / Removal (Shown with a Straddle Mount Connector)

2.1.2 Large Form Factor (LFF) Faceplate Configurations

The [large form factor \(LFF\)](#) configuration views are shown below. A single faceplate implementation is available for the LFF – with a single ejector latch. The long ejector is the default configuration, however, a short ejector version is available for non-shadowed front I/O configurations and is being considered for future development. Similar to the SFF, if additional LFF faceplate implementations become available, the same LFF OCP NIC 3.0 PBA assembly shall be able to accept new faceplate types and may

be interchanged depending on the end application. The drawings shown in Figure 10 below illustrate a representative front, side and top views of the LFF.

Where space is permitted on the faceplate, square vents sized to a maximum of 3.0 mm x 3.0 mm must be added to help optimize airflow while maintaining the integrity of the faceplate structure. EMI considerations should also be taken into account during the design process. Refer to the images shown in Figure 11 for example square vent configurations depending on the line side I/O connectors.

Depending on the OCP NIC 3.0 card implementation, I/O connectors may be placed anywhere within the allowable connector keep in regions as defined by the PBA mechanical drawings and faceplate drawings of Section 2.5

Note: The OCP NIC 3.0 card supplier shall add port identification on the faceplate assembly that meet their manufacturing and customer requirements.

All of the OCP NIC 3.0 CAD files are available for download and use on the OCP NIC 3.0 Wiki site:
<http://www.opencompute.org/wiki/Server/Mezz>

Figure 10: LFF NIC Configuration Views
~~Large Form Factor (LFF)~~ with Ejector Latch

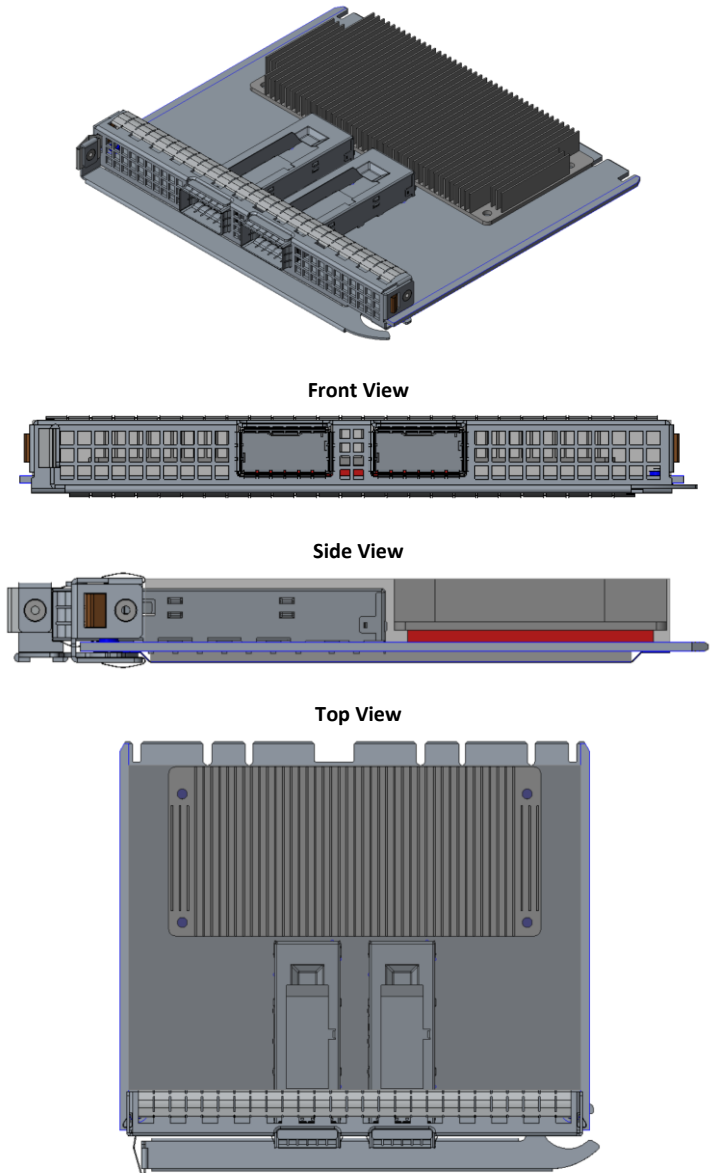

Figure 11 illustrates example LFF 3D views for the supported line side I/O implementations. The line side I/O implementations are discussed in Section 2.2.

Figure 11: LFF NIC Line Side 3D Views

~~Large Form Factor (LFF) with Long Ejector Latch~~ ~~Large Form Factor (LFF) with Short Ejector Latch~~

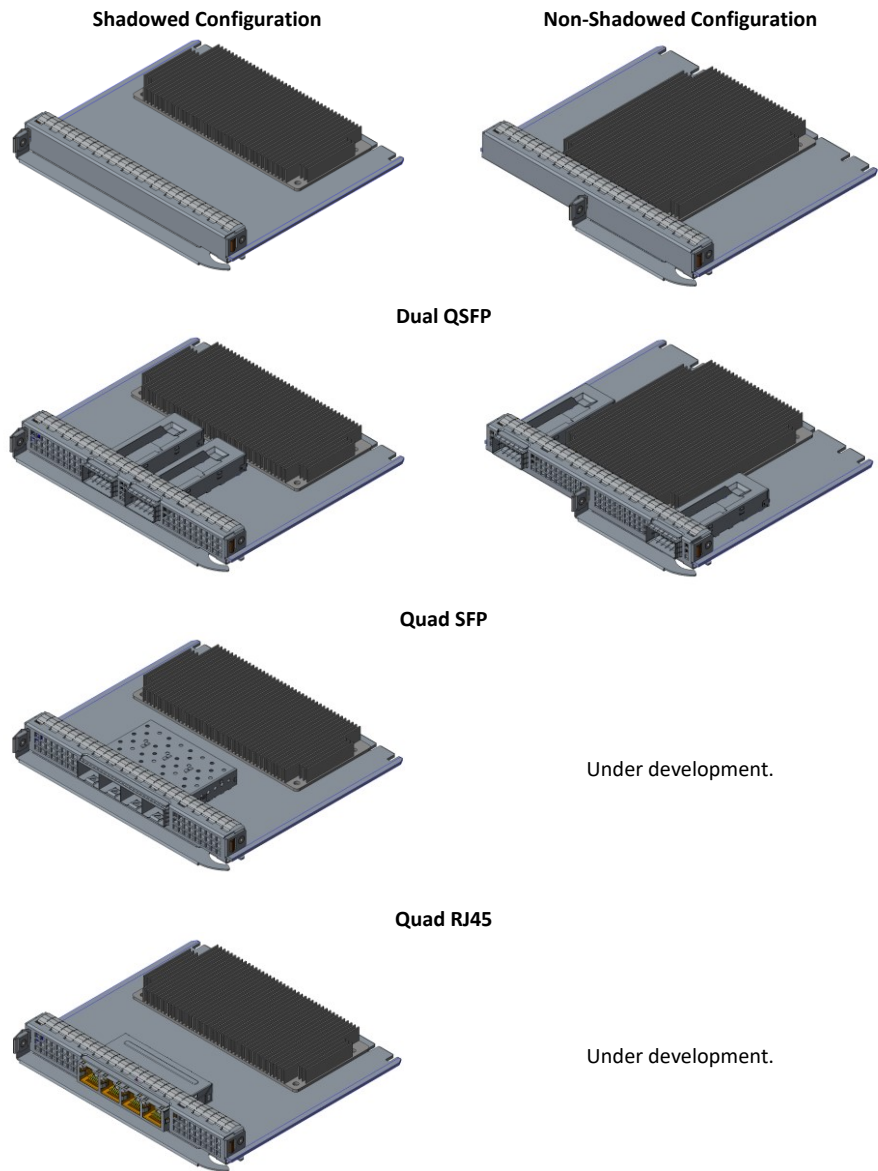
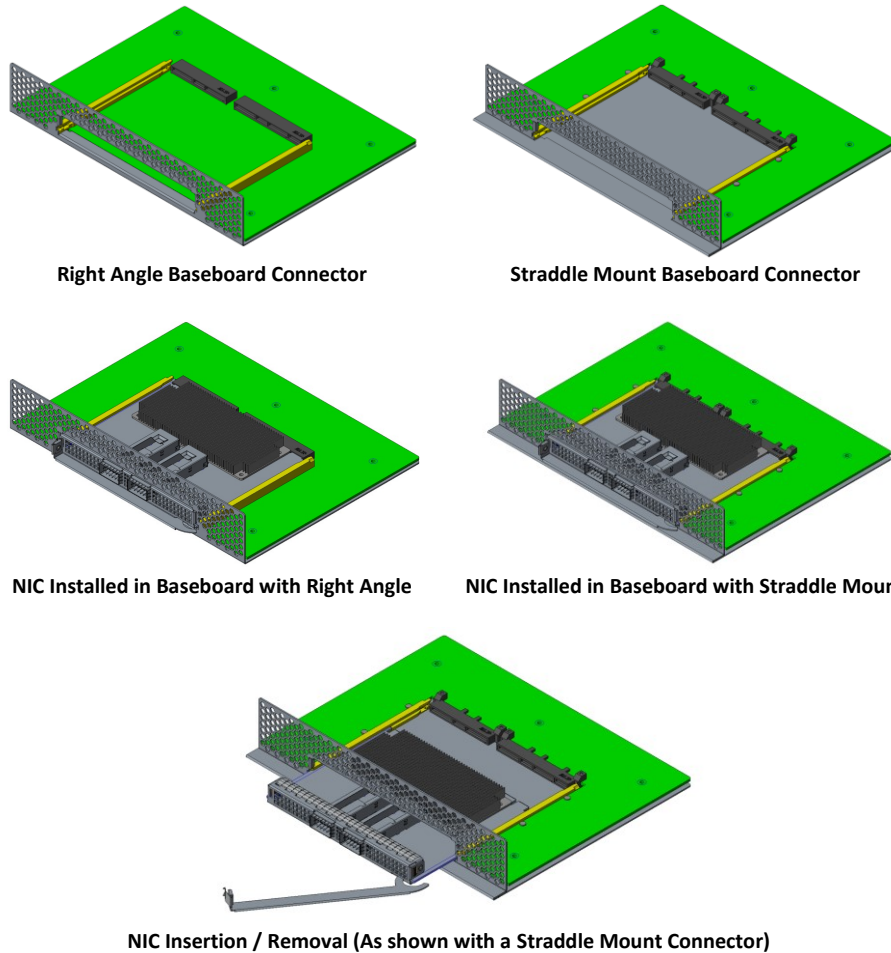

Figure 12 illustrates example LFF 3D views of the ejector latch assembly mounted in a chassis utilizing a straddle mount connector and a right angle connector. The baseboard connector options are discussed in Section 3.2. The LFF OCP NIC 3.0 card is identical for both chassis connector options.

Figure 12: LFF NIC Chassis Mounted 3D Views



2.2 Line Side I/O Implementations

At the time of this writing, the ~~Small-SFF~~ and ~~Large form factor-LFF~~ implementations have been optimized to support the following standard line side I/O implementations:

Table ~~76~~: OCP NIC 3.0 Line Side I/O Implementations

Form Factor	Max Topology Connector Count
SFF	2x QSFP+/QSFP28
SFF	4x SFP28+/SFP28
SFF	4x RJ-45
LFF	2x QSFP+/QSFP28
LFF	4x SFP+/SFP28
LFF	4x RJ-45

Note: For brevity, references to QSFP+, and QSFP28 shall be referred to as QSFP for the remainder of this document. Similarly, references to SFP+, and SFP28 shall be referred to as SFP.

Additional combinations and connector types are permissible as I/O form-factor technologies and thermal capabilities evolve.

2.3 Top Level Assembly (SFF and LFF)

The images in Figure 13 illustrate the exploded top level assemblies for both the SFF and the LFF.

Figure 13: PBA Exploded Views (SFF and LFF)

Small Form Factor (SFF) with Pull Tab

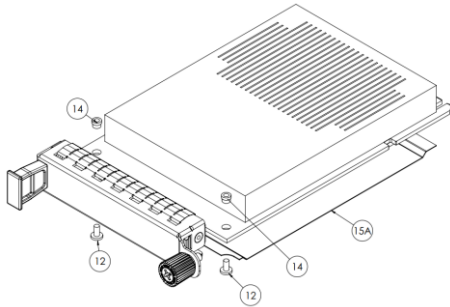

Small Form Factor (SFF) with Ejector Latch

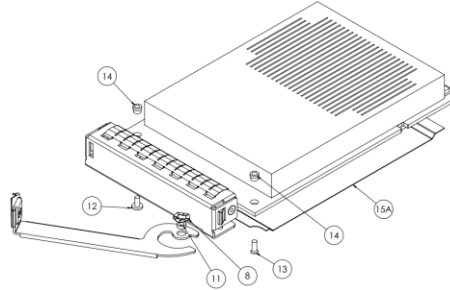

Small Form Factor (SFF) with Internal Lock

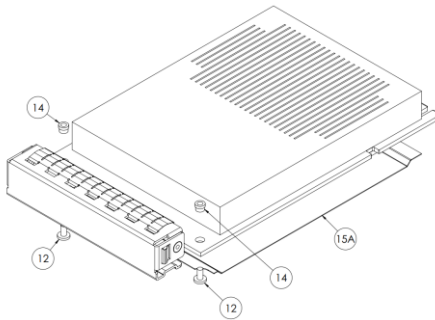

Large Form Factor (LFF) with Ejector Latch

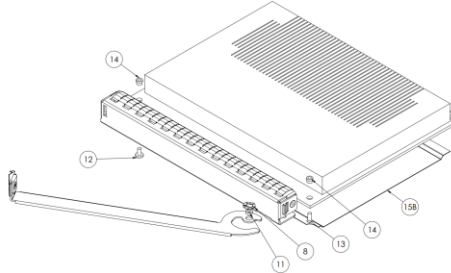

Diagram callouts #8, and #11 through #15 are installed at the NIC assembly level:

- Item #8 and #11 – Wave washer and bushing are part of the ejector latch mechanism.
- Item #12 & #13 – Screws used to attach the faceplate assembly to the OCP NIC 3.0 PBA.
- Item #14 – 2x SMT nuts installed on to the PBA assembly using the reflow process.
- Item #15 – Insulator is located on the secondary side and is installed on the PBA prior to the faceplate.

2.4 Faceplate Subassembly (SFF and LFF)

The following section define the generic [small form factor and large form factor](#) [SFF and LFF](#) faceplates.

2.4.1 Faceplate Subassembly – Exploded View

The images in Figure 14 illustrate the three faceplates subassemblies as exploded views. The bill of materials is shown in Section 2.4.2.

Figure 14: Faceplate Assembly Exploded Views (SFF and LFF)

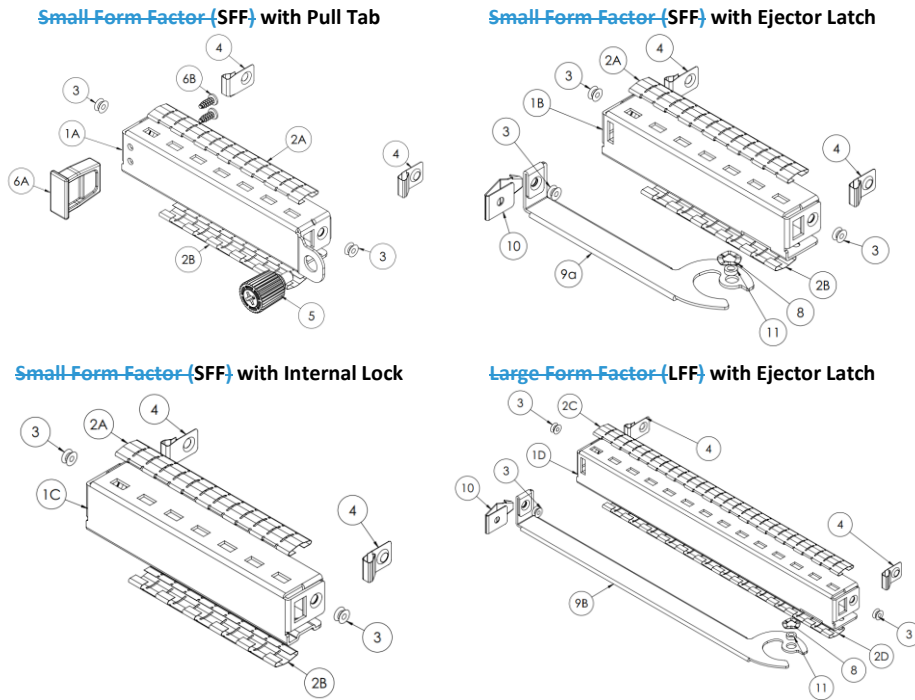

2.4.2 Faceplate Subassembly – Bill of Materials (BOM)

[Table 8Table-7](#) shows the bill of materials for the SFF and LFF assemblies. Item number call outs align with the SFF and LFF numbering of Figure 14.

Note: Dimensionally identical equivalent parts and equivalent materials may be substituted in the assembly. Substituted parts and materials shall meet or exceed the tolerances and requirements specified by the supplier part numbers of [Table 8Table-7](#). Refer to the 3D CAD files for hardware specifics not covered by this table.

Table 87: Bill of Materials for the SFF and LFF Faceplate Assemblies

Item #	Item description	Part Number / Drawing	Supplier								
1A 1B 1C 1D	Faceplate	See Section 2.4.3: <table border="1"> <tr> <td>1A</td> <td>NIC_OCPv3_SFF_Faceplate_Pulltab_20180601.pdf</td> </tr> <tr> <td>1B</td> <td>NIC_OCPv3_SFF_Faceplate_Latch_20180601.pdf</td> </tr> <tr> <td>1C</td> <td>NIC_OCPv3_SFF_Faceplate_IntLock_20180601.pdf</td> </tr> </table> See Section 2.4.4: <table border="1"> <tr> <td>1D</td> <td>NIC_OCPv3_LFF_Faceplate_Latch_20180601.pdf</td> </tr> </table>	1A	NIC_OCPv3_SFF_Faceplate_Pulltab_20180601.pdf	1B	NIC_OCPv3_SFF_Faceplate_Latch_20180601.pdf	1C	NIC_OCPv3_SFF_Faceplate_IntLock_20180601.pdf	1D	NIC_OCPv3_LFF_Faceplate_Latch_20180601.pdf	Custom
1A	NIC_OCPv3_SFF_Faceplate_Pulltab_20180601.pdf										
1B	NIC_OCPv3_SFF_Faceplate_Latch_20180601.pdf										
1C	NIC_OCPv3_SFF_Faceplate_IntLock_20180601.pdf										
1D	NIC_OCPv3_LFF_Faceplate_Latch_20180601.pdf										
2A 2B 2C 2D	Top and Bottom EMI Fingers	<table border="1"> <tr> <td>2A</td> <td>LT18CJ1921 – 13 fingers (Laird) TF187VE32F11-2.41-08 (Tech-Etch)</td> </tr> <tr> <td>2B</td> <td>LT18CJ1920 – 11 fingers (Laird) TF187VE32F11-2.04-08 (Tech-Etch)</td> </tr> <tr> <td>2C</td> <td>LT18CJ1923 – 27 fingers (Laird) TF187VE32F11-5.03-08 (Tech-Etch)</td> </tr> <tr> <td>2D</td> <td>LT18CJ1922 – 25 fingers (Laird) TF187VE32F11-4.66-08 (Tech-Etch)</td> </tr> </table>	2A	LT18CJ1921 – 13 fingers (Laird) TF187VE32F11-2.41-08 (Tech-Etch)	2B	LT18CJ1920 – 11 fingers (Laird) TF187VE32F11-2.04-08 (Tech-Etch)	2C	LT18CJ1923 – 27 fingers (Laird) TF187VE32F11-5.03-08 (Tech-Etch)	2D	LT18CJ1922 – 25 fingers (Laird) TF187VE32F11-4.66-08 (Tech-Etch)	Laird, Tech-ETCH
2A	LT18CJ1921 – 13 fingers (Laird) TF187VE32F11-2.41-08 (Tech-Etch)										
2B	LT18CJ1920 – 11 fingers (Laird) TF187VE32F11-2.04-08 (Tech-Etch)										
2C	LT18CJ1923 – 27 fingers (Laird) TF187VE32F11-5.03-08 (Tech-Etch)										
2D	LT18CJ1922 – 25 fingers (Laird) TF187VE32F11-4.66-08 (Tech-Etch)										
3	Rivet	1-AC-2421-03_2.4x2.1	Dong Guan KSETT Hardware Technology								
4	Side EMI Fingers	LT18DP1911	Laird								
5	Thumbscrew	4C-99-343- K077 K081	Southco, Inc.								
6A 6B	Pull tab w/2x screws	CN-99-459	Southco, Inc.								
8	Ejector Wave Compression Washer	See Section 2.4.9 and drawing NIC_OCPv3_EjectorWasher_20180601.pdf	Custom								
9A 9B	Ejector Handle	SFF Ejector: See Section 2.4.5 and drawing <table border="1"> <tr> <td>9A</td> <td>NIC_OCPv3_EjectorHandle_Short_20180601.pdf</td> </tr> </table> Note: The SFF ejector is also used on the LFF non-shadowed I/O faceplate configuration. LFF Ejector: See Section 2.4.6 & Drawing <table border="1"> <tr> <td>9B</td> <td>NIC_OCPv3_EjectorHandle_Long_20180601.pdf</td> </tr> </table>	9A	NIC_OCPv3_EjectorHandle_Short_20180601.pdf	9B	NIC_OCPv3_EjectorHandle_Long_20180601.pdf	Custom				
9A	NIC_OCPv3_EjectorHandle_Short_20180601.pdf										
9B	NIC_OCPv3_EjectorHandle_Long_20180601.pdf										
10	Ejector Lock	See Section 2.4.7 and drawing NIC_OCPv3_EjectorLock_20180601.pdf	Custom								
11	Ejector Bushing	See Section 2.4.8 and drawing NIC_OCPv3_EjectorBushing_20180601.pdf	Custom								
12	Screw for securing faceplate to NIC	ICMMAJ200403N3 ICMMBS200403N	WUJIANG Screw Tech Precision Industry								
13	Screw for attaching faceplate and ejector to NIC	FCMMQ200503N	WUJIANG Screw Tech Precision Industry								
14	SMT nut (on NIC)	82-950-22-010- 0405 -RL	Fivetech Technology Inc.								
15A 15B	Insulator	Refer to Section 2.7 for the SFF (15A) and LFF (15B) insulator mechanical requirements	Custom								

2.4.3 SFF Generic I/O Faceplate

Figure 15 shows the standard SFF I/O bracket with a thumbscrew and pull tab assembly.

Figure 15: SFF Generic I/O Faceplate with Pulltab Version (2D View)

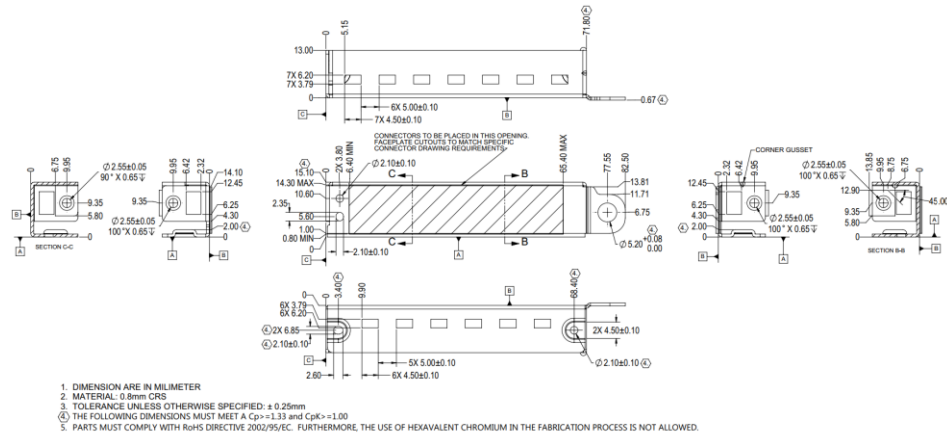
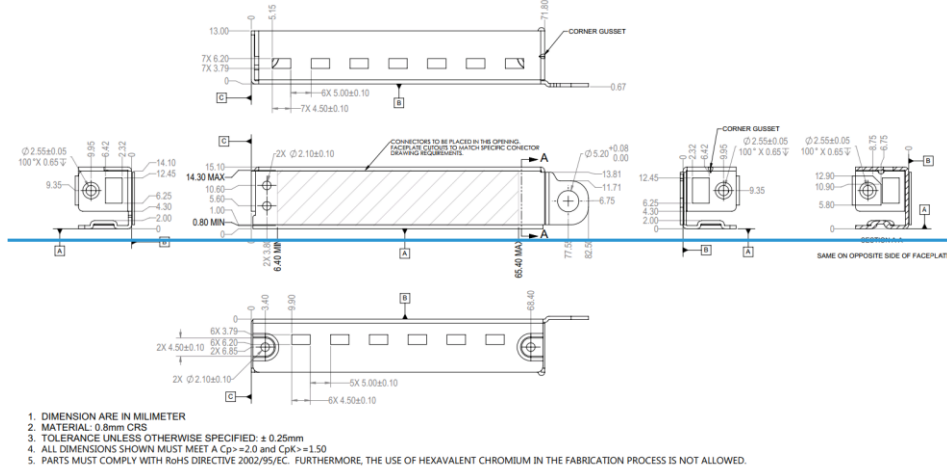
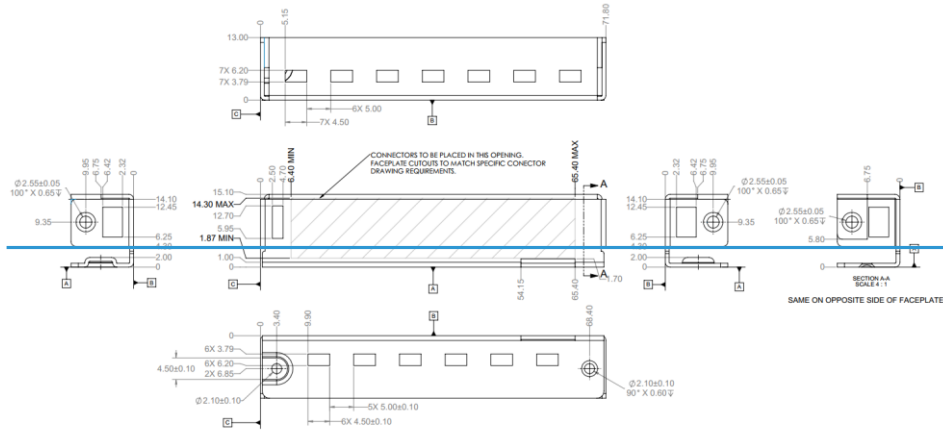
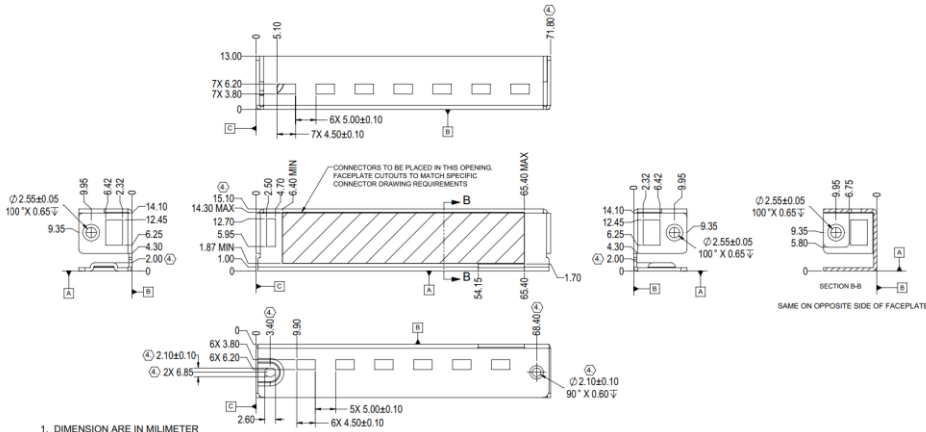

Figure 16: SFF Generic I/O Faceplate – Ejector Version (2D View)



1. DIMENSION ARE IN MILLIMETER
2. MATERIAL: 0.8mm CRS
3. TOLERANCE UNLESS OTHERWISE SPECIFIED: ± 0.25mm
4. ALL DIMENSIONS SHOWN MUST MEET A Cp>=2.0 and Cpk>=1.50
5. PARTS MUST COMPLY WITH RoHS DIRECTIVE 2002/95/EC. FURTHERMORE, THE USE OF HEXAVALENT CHROMIUM IN THE FABRICATION PROCESS IS NOT ALLOWED.



1. DIMENSION ARE IN MILLIMETER
2. MATERIAL: 0.8mm CRS
3. TOLERANCE UNLESS OTHERWISE SPECIFIED: ± 0.25mm
4. THE FOLLOWING DIMENSIONS MUST MEET A Cp>=1.33 and Cpk>=1.00
5. PARTS MUST COMPLY WITH RoHS DIRECTIVE 2002/95/EC. FURTHERMORE, THE USE OF HEXAVALENT CHROMIUM IN THE FABRICATION PROCESS IS NOT ALLOWED.

Figure 17: SFF Generic I/O Faceplate – Internal Lock Version (2D View)

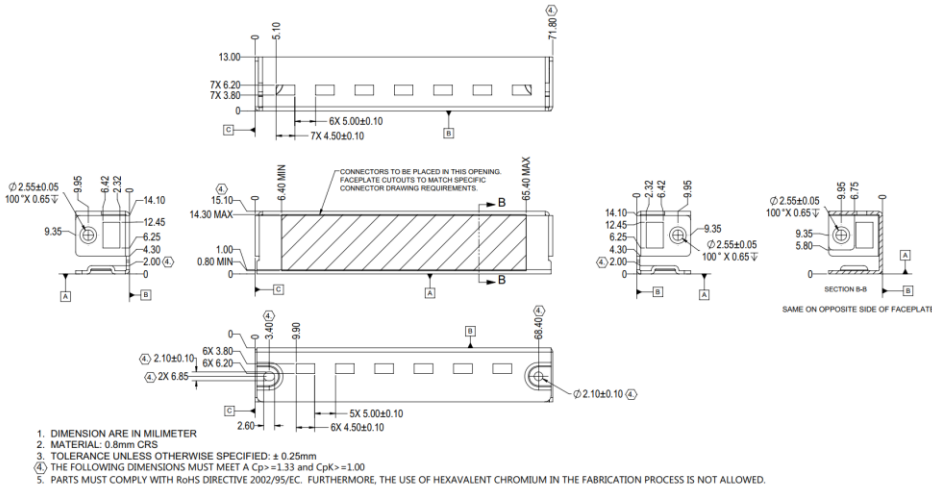
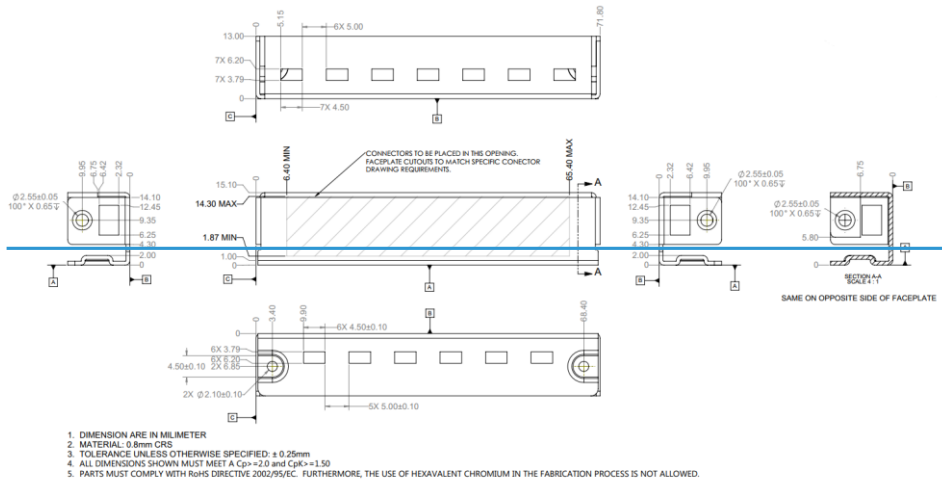

2.4.4 LFF Generic I/O Faceplate

Figure 18: LFF Generic I/O Faceplate – Dual Ejector Version (2D View)

Open Compute Project • OCP NIC 3.0

Rev ~~0.840-83~~

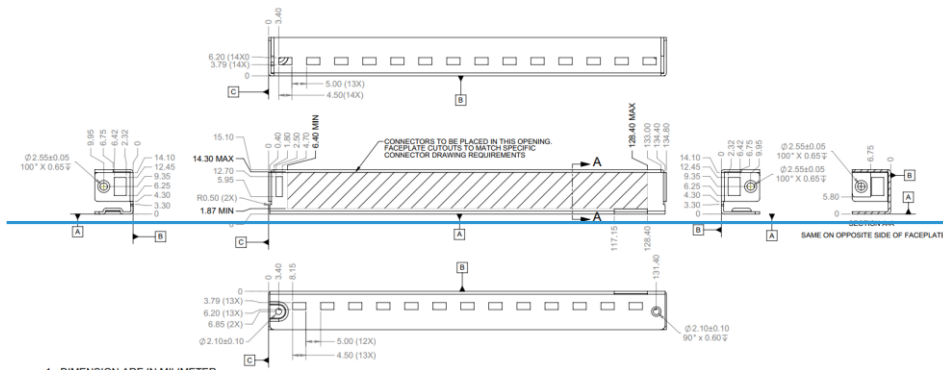

- 1. DIMENSION ARE IN MILLIMETER
- 2. MATERIAL: 0.8mm CRS
- 3. TOLERANCE UNLESS OTHERWISE SPECIFIED: $\pm 0.25\text{mm}$
- 4. ALL DIMENSIONS SHOWN MUST MEET A $Cp >= 2.0$ and $Cpk >= 1.50$
- 5. PARTS MUST COMPLY WITH RoHS DIRECTIVE 2002/95/EC. FURTHERMORE, THE USE OF HEXAVALENT CHROMIUM IN THE FABRICATION PROCESS IS NOT ALLOWED.

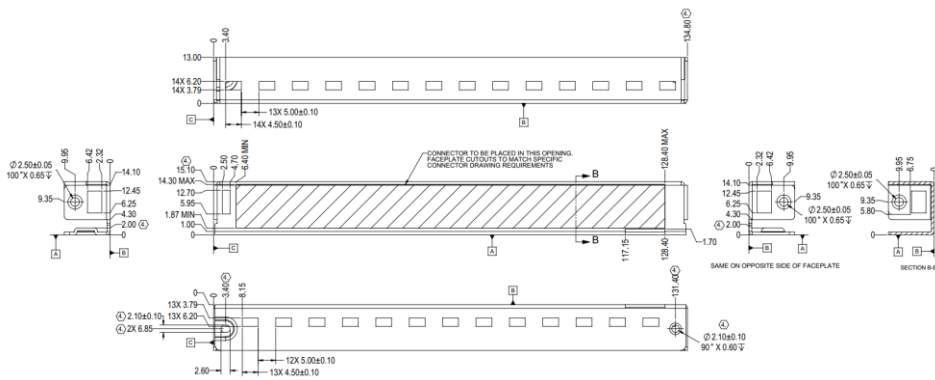

- 1. DIMENSION ARE IN MILLIMETER
- 2. MATERIAL: 0.8mm CRS
- 3. TOLERANCE UNLESS OTHERWISE SPECIFIED: $\pm 0.25\text{mm}$
- 4. THE FOLLOWING DIMENSIONS MUST MEET A $Cp >= 1.33$ and $Cpk >= 1.00$
- 5. PARTS MUST COMPLY WITH RoHS DIRECTIVE 2002/95/EC. FURTHERMORE, THE USE OF HEXAVALENT CHROMIUM IN THE FABRICATION PROCESS IS NOT ALLOWED.

2.4.5 Ejector Lever (SFF)

This section defines the SFF lever dimensions. Note: this SFF ejector lever is also used on the non-shadowed LFF faceplate configuration.

Figure 19: SFF I/O Faceplate – Ejector Lever (2D View)

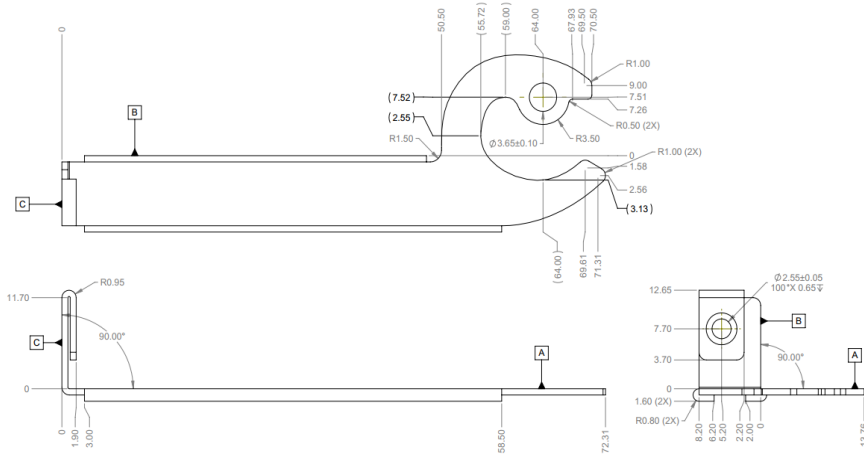

1. DIMENSION ARE IN MILLIMETER
2. MATERIAL: 0.8mm 301 SS 1/4 HARD
3. TOLERANCE UNLESS OTHERWISE SPECIFIED: $\pm 0.25\text{mm}$, $\pm 1.0^\circ$

2.4.6 Ejector Levers (LFF)

This section defines the LFF ejector lever dimensions.

Figure 20: LFF I/O Faceplate – Ejector Lever (2D View)

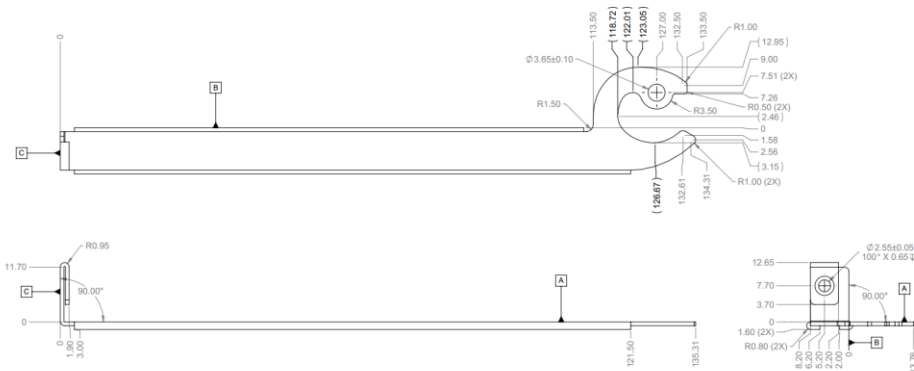

1. DIMENSION ARE IN MILLIMETER
2. MATERIAL: 0.8mm 301 SS 1/4 HARD
3. TOLERANCE UNLESS OTHERWISE SPECIFIED: $\pm 0.25\text{mm}$, $\pm 1.0^\circ$
4. PARTS MUST COMPLY WITH RoHS DIRECTIVE 2002/95/EC. FURTHERMORE, THE USE OF HEXAVALENT CHROMIUM IN THE FABRICATION PROCESS IS NOT ALLOWED.

2.4.7 Ejector Lock (SFF and LFF)

The SFF and LFF ejector uses a locking mechanism at the end of the handle to retain the lever position. This is shown in Figure 21.

Figure 21: Ejector Lock

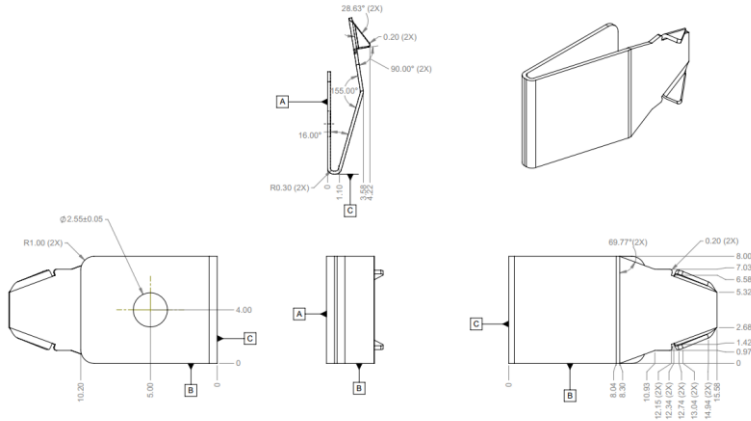

1. DIMENSION ARE IN MILLIMETER
2. MATERIAL: 0.3mm 301 SS 1/2 HARD
3. TOLERANCE UNLESS OTHERWISE SPECIFIED: $\pm 0.25\text{mm}$, $\pm 1.0^\circ$
4. PARTS MUST COMPLY WITH RoHS DIRECTIVE 2002/95/EC. FURTHERMORE, THE USE OF HEXAVALENT CHROMIUM IN THE FABRICATION PROCESS IS NOT ALLOWED.

2.4.8 Ejector Bushing (SFF and LFF)

The SFF and LFF card ejector handle uses a bushing as a spacer and rotation anchor. This is shown in Figure 22.

Figure 22: Ejector Bushing

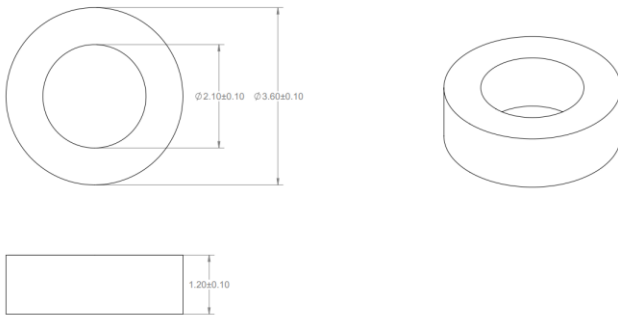

1. DIMENSION ARE IN MILLIMETER
2. MATERIAL: STEEL SAE 1215
3. TOLERANCE UNLESS OTHERWISE SPECIFIED: $\pm 0.25\text{mm}$, $\pm 1.0^\circ$
4. PARTS MUST COMPLY WITH RoHS DIRECTIVE 2002/95/EC. FURTHERMORE, THE USE OF HEXAVALENT CHROMIUM IN THE FABRICATION PROCESS IS NOT ALLOWED.

2.4.9 Ejector Wave Washer (SFF and LFF)

The SFF and LFF card ejector handle uses a wave washer between the handle and faceplate assembly. This is shown in Figure 23.

Figure 23: Wave Washer

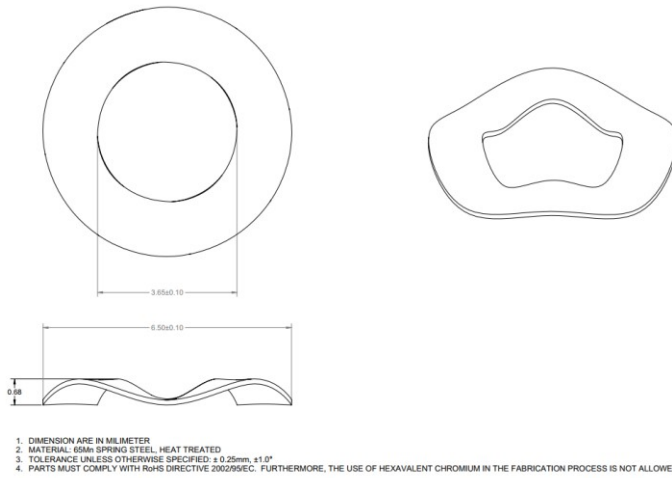

2.5 Card Keep Out Zones

2.5.1 SFF Keep Out Zones

Figure 24: SFF Keep Out Zone – Top View

Open Compute Project • OCP NIC 3.0

Rev 0.840-83

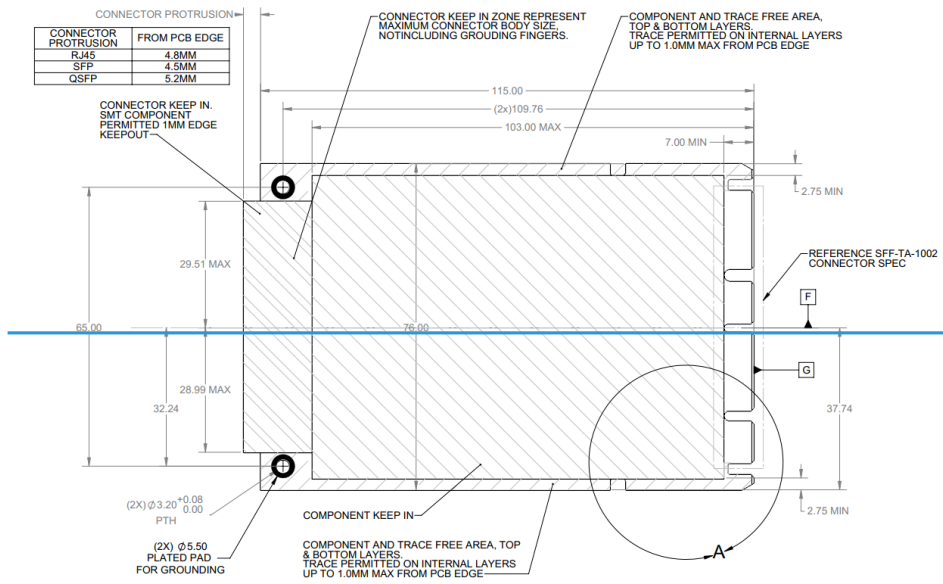

NOTES:
1. TOLERANCE UNLESS OTHERWISE SPECIFIED: ±0.13, ±1.0°

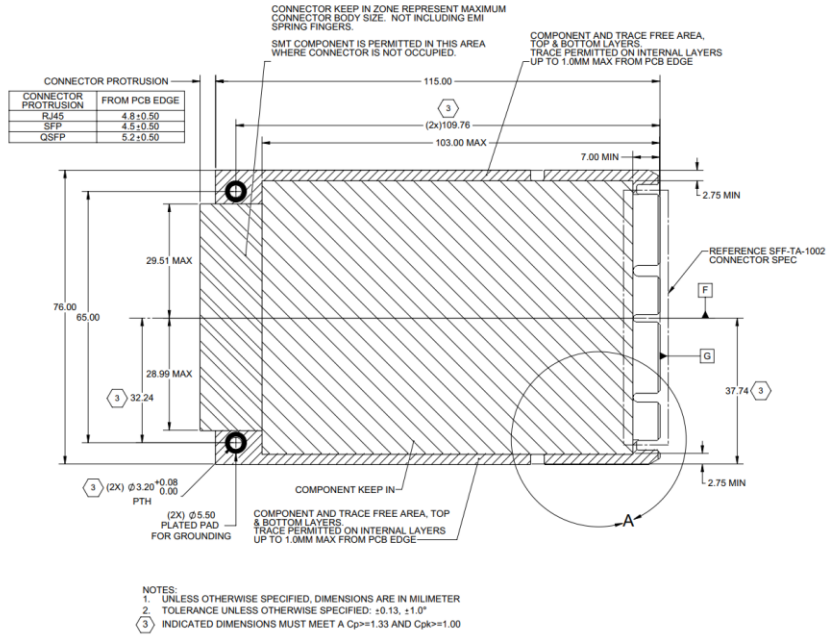
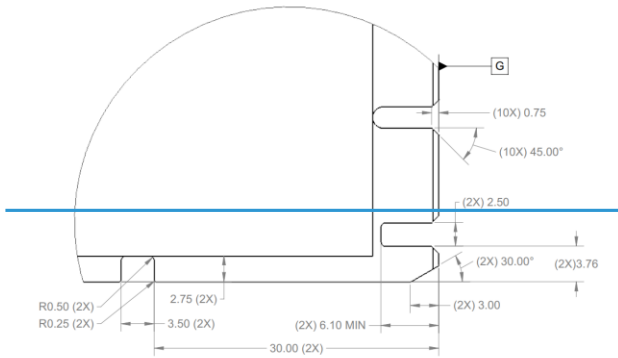
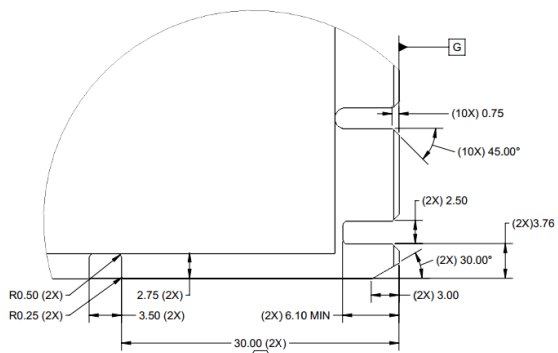

Figure 25: SFF Keep Out Zone – Top View – Detail A



DETAIL A
SCALE 4 : 1



DETAIL A
SCALE 4 : 1

Figure 26: SFF Keep Out Zone – Bottom View

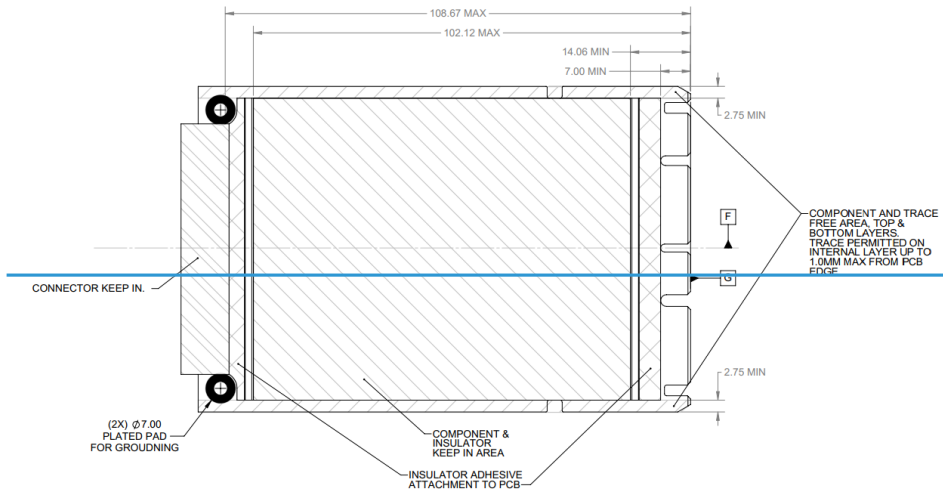

NOTES:
1. TOLERANCE UNLESS OTHERWISE SPECIFIED: $\pm 0.13, \pm 1.0^\circ$

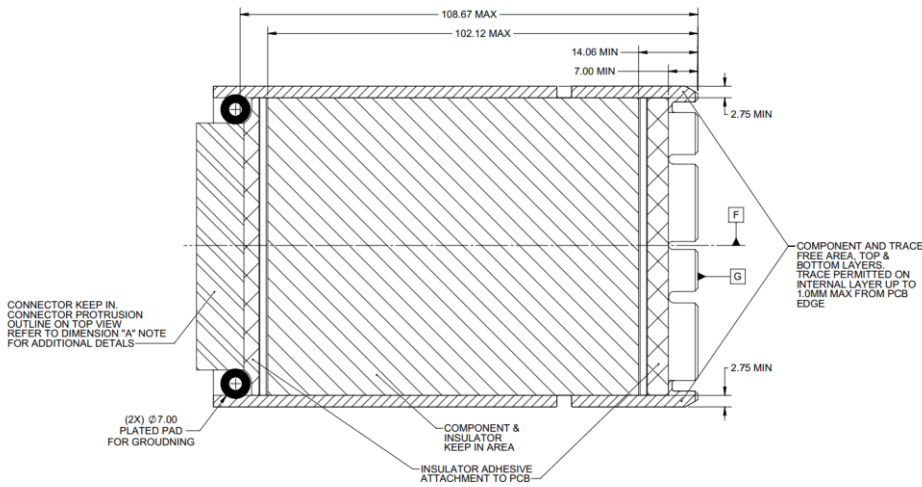

NOTES:
1. UNLESS OTHERWISE SPECIFIED, DIMENSIONS ARE IN MILLIMETER
2. TOLERANCE UNLESS OTHERWISE SPECIFIED: $\pm 0.13, \pm 1.0^\circ$

Figure 27: SFF Keep Out Zone – Side View

DIMENSION "A" CONNECTOR HEIGHT	MAX (mm)
WITH LATCH	1.70
W/O LATCH	2.77

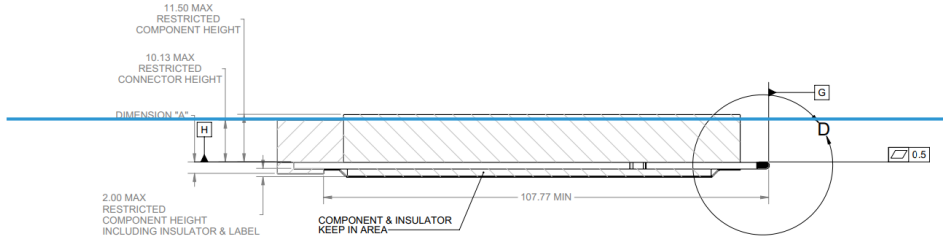

NOTES:
1. TOLERANCE UNLESS OTHERWISE SPECIFIED: $\pm 0.13, \pm 1.0^\circ$

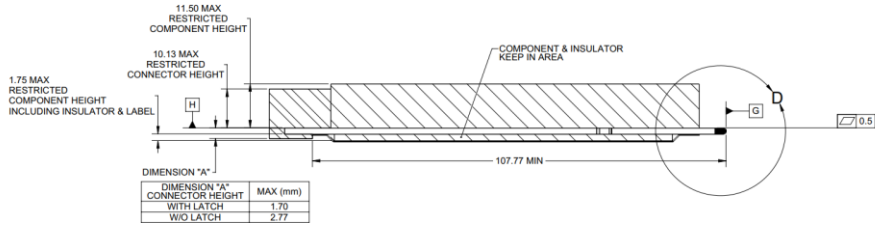

DIMENSION "A" CONNECTOR HEIGHT	MAX (mm)
WITH LATCH	1.70
W/O LATCH	2.77

NOTES:
1. UNLESS OTHERWISE SPECIFIED, DIMENSIONS ARE IN MILLIMETER
2. TOLERANCE UNLESS OTHERWISE SPECIFIED: $\pm 0.13, \pm 1.0^\circ$

Note: The area defined by DIMENSION "A" is between the faceplate and the primary side of the board. Grounded through-hole mounting pins are permitted but should avoid making contact with the latching mechanism and EMI fingers. Signal pins are not permitted in this area.

Figure 28: SFF Keep Out Zone – Side View – Detail D

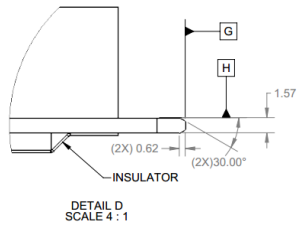

2.5.2 LFF Keep Out Zones

Figure 29: LFF Keep Out Zone – Top View

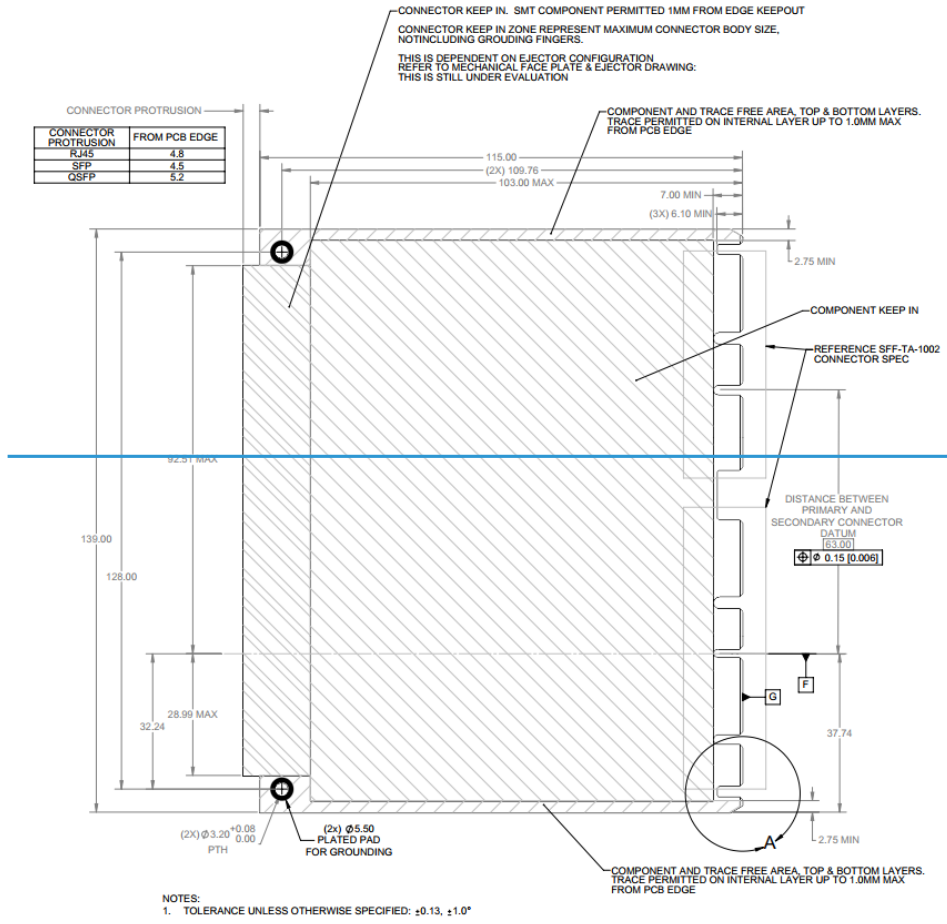

Open Compute Project • OCP NIC 3.0

Rev ~~0.840-83~~

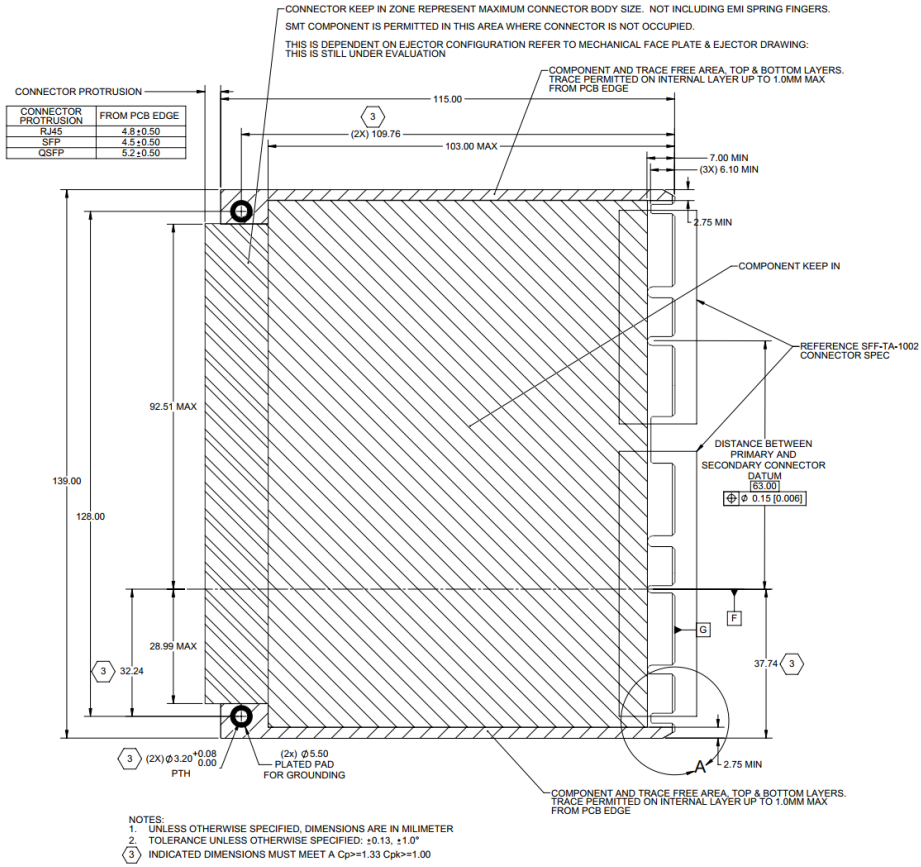

Figure 30: LFF Keep Out Zone – Top View – Detail A

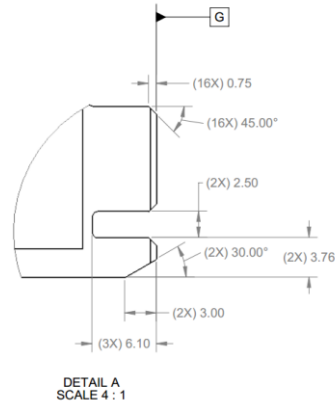
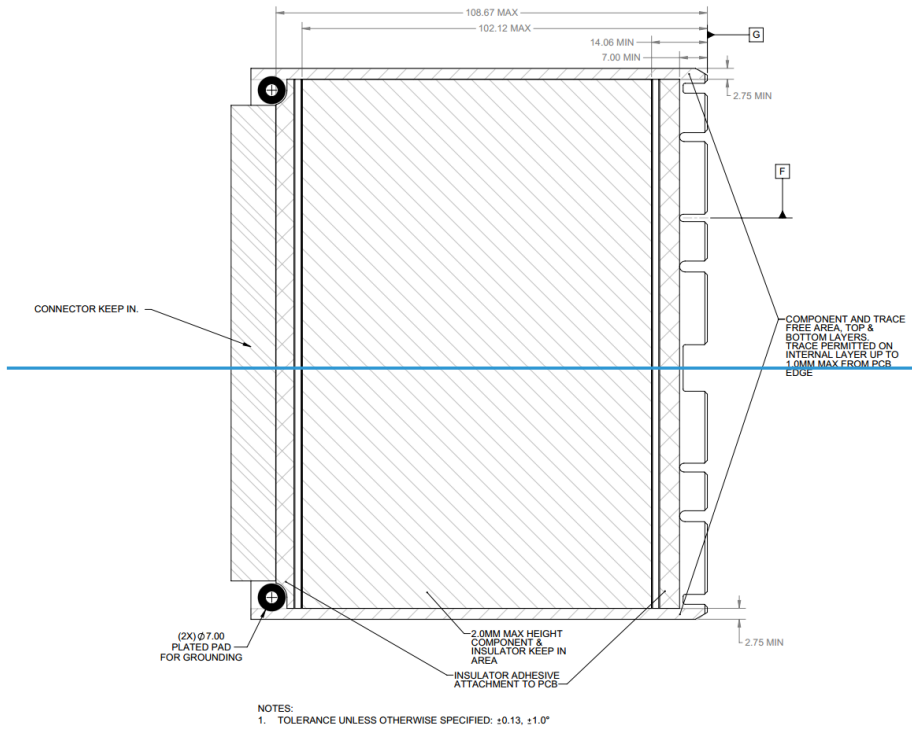

Figure 31: LFF Keep Out Zone – Bottom View



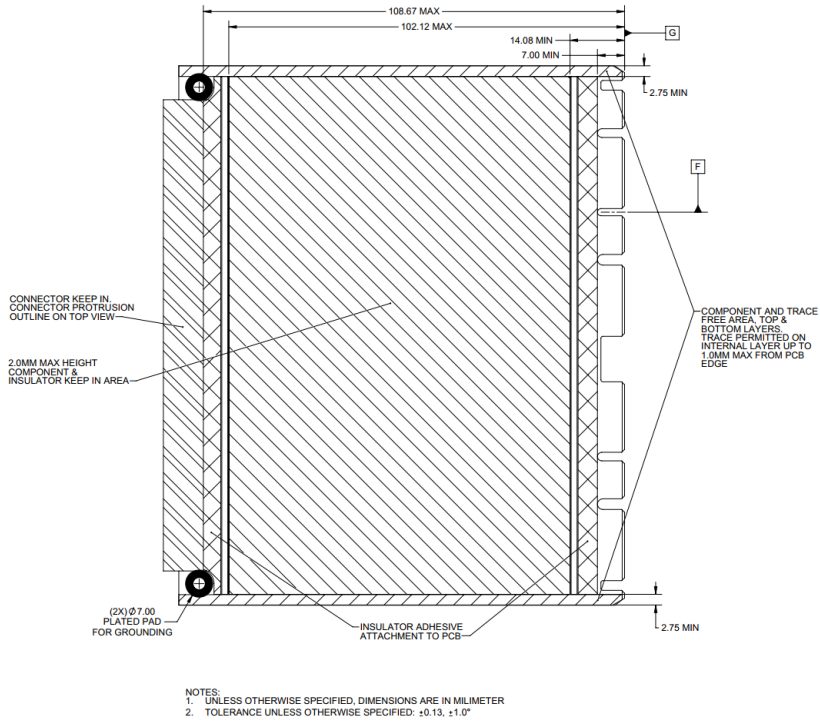

Figure 32: LFF Keep Out Zone – Side View

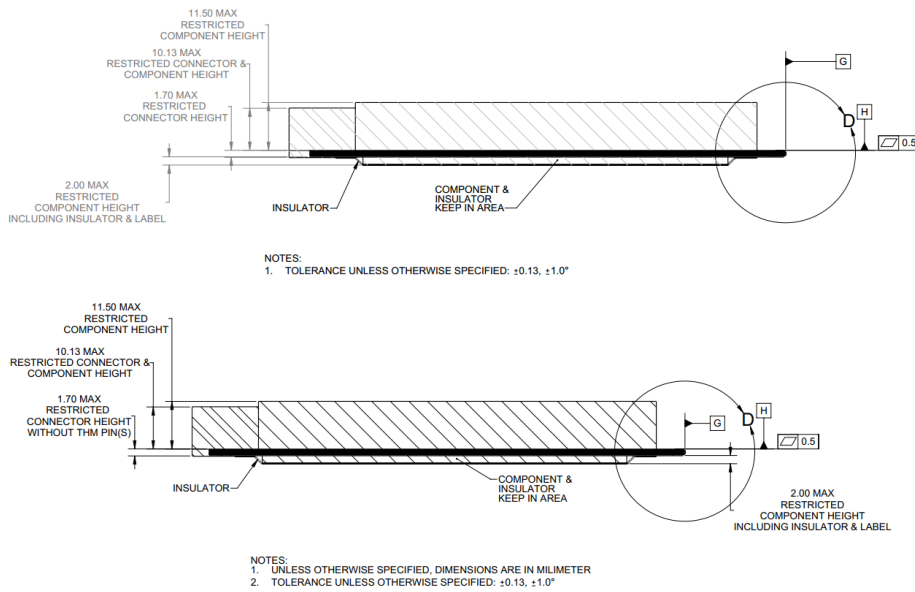
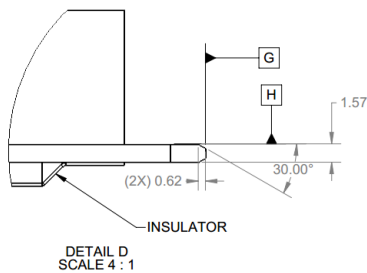

Figure 33: LFF Keep Out Zone – Side View – Detail D



2.6 Baseboard Keep Out Zones

Refer to the 3D CAD files for the baseboard keep out zones for both the [Small and Large form factor SFF and LFF](#) designs. The 3D CAD files are available for download on the OCP NIC 3.0 Wiki: <http://www.opencompute.org/wiki/Server/Mezz>

2.7 Insulation Requirements

All OCP NIC 3.0 cards shall implement an insulator to prevent the bottom side card components from shorting out to the baseboard chassis. The recommended insulator thickness is 0.25 mm and shall reside within the following mechanical envelope for the ~~Small and Large size cards~~ [SFF and LFF](#).

2.7.1 SFF Insulator

Figure 34: SFF Bottom Side Insulator (3D View)

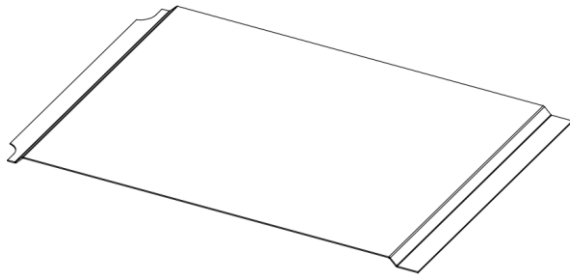
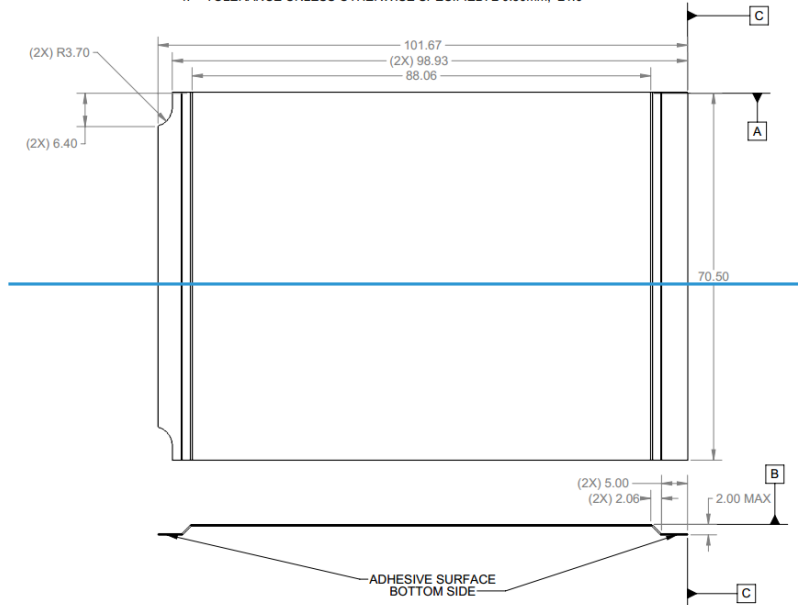

Figure 35: SFF Bottom Side Insulator (Top and Side View)

Open Compute Project • OCP NIC 3.0

Rev ~~0.840-83~~

1. DIMENSION ARE IN MILIMETER
2. MATERIAL: FORMEX GK-10BK 0.25mm THICKNESS
3. ADHESIVE 3M 467MP 0.05mm THICKNESS
4. TOLERANCE UNLESS OTHERWISE SPECIFIED: $\pm 0.30\text{mm}$, $\pm 1.0^\circ$



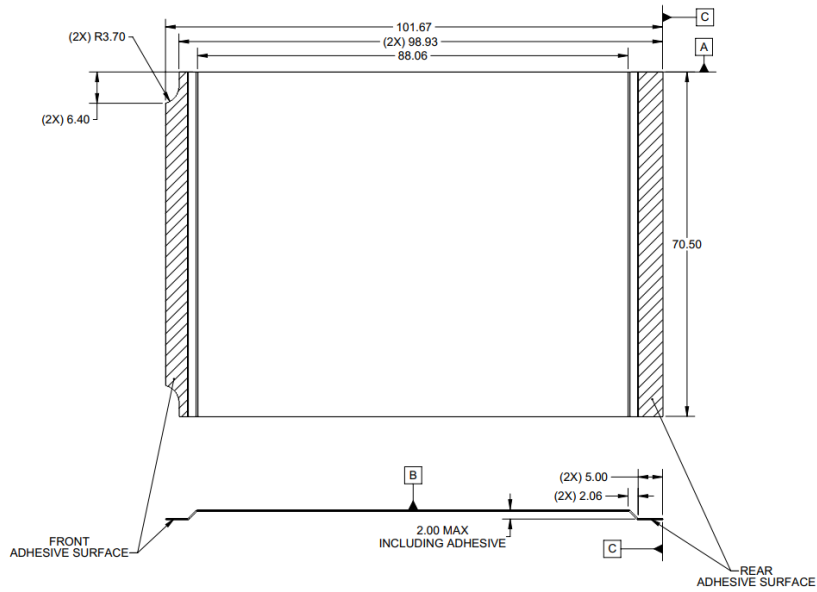

1. DIMENSION ARE IN MILIMETER
2. MATERIAL: FORMEX GK-10BK or FORMEX N3 (HALOGEN FREE, BLACK OR NATURAL), 0.25mm THICKNESS
3. MATERIAL SHALL CONFORM TO 94VTM-0
4. ADHESIVE 3M 467MP 0.05mm THICKNESS
5. TOLERANCE UNLESS OTHERWISE SPECIFIED: $\pm 0.30\text{mm}$, $\pm 1.0^\circ$

[Figure 36: SFF Bottom Side Insulator \(alternate\) \(Top and Side View\)](#)

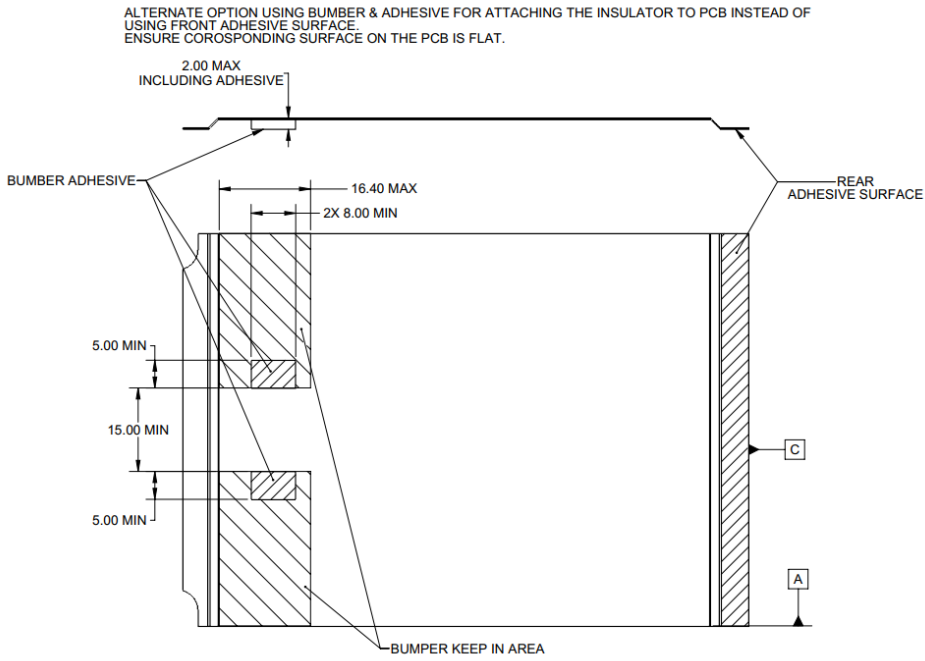

2.7.2 LFF Insulator

Figure [3736](#): LFF Bottom Side Insulator (3D View)

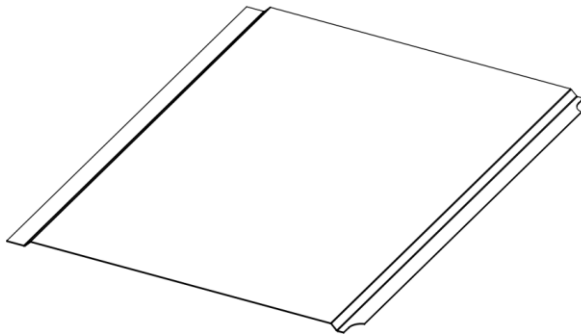
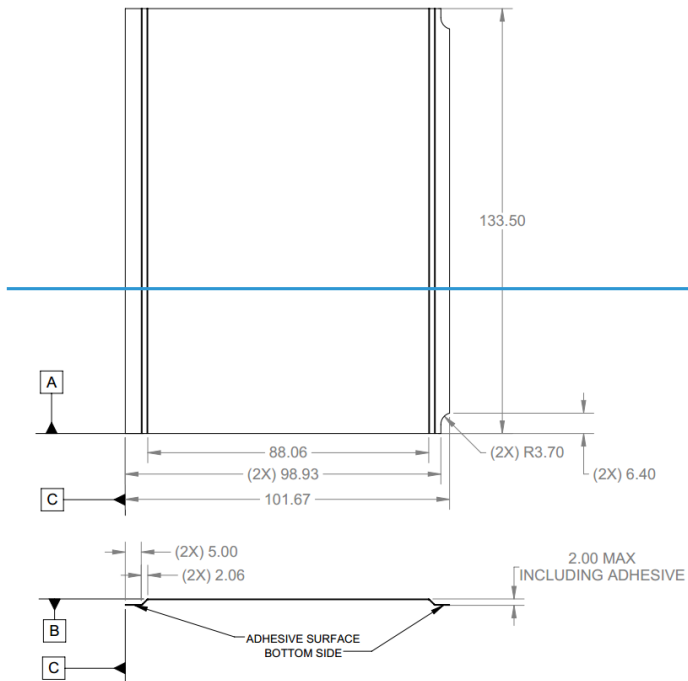
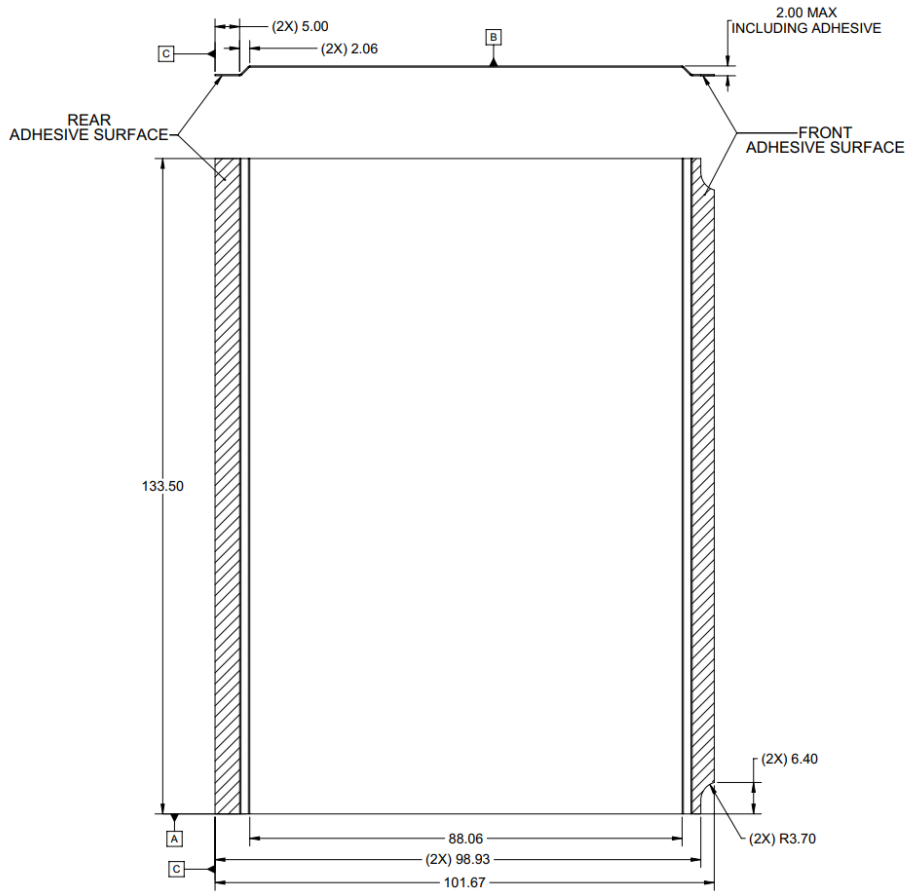

Figure [3837](#): LFF Bottom Side Insulator (Top and Side View)

1. DIMENSION ARE IN MILIMETER
2. MATERIAL: FORMEX GK-10BK 0.25mm THICKNESS
3. ADHESIVE 3M 467MP 0.05mm THICKNESS
4. TOLERANCE UNLESS OTHERWISE SPECIFIED: $\pm 0.30\text{mm}$, $\pm 1.0^\circ$





1. DIMENSION ARE IN MILIMETER
2. MATERIAL: FORMEX GK-10BK, FORMEX N3 (HALOGEN FREE, BLACK OR NATURAL), 0.25mm THICKNESS
3. MATERIAL SHALL CONFORM TO 94VTM-0
4. ADHESIVE 3M 467MP 0.05mm THICKNESS
5. TOLERANCE UNLESS OTHERWISE SPECIFIED: $\pm 0.30\text{mm}$, $\pm 1.0^\circ$

Figure 39: LFF Bottom Side Insulator (alternate) (Top and Side View)

ALTERNATE OPTION USING BUMBER & ADHESIVE FOR ATTACHING THE INSULATOR TO PCB INSTEAD OF USING FRONT ADHESIVE SURFACE.
ENSURE CORRESPONDING SURFACE ON PCB IS FLAT

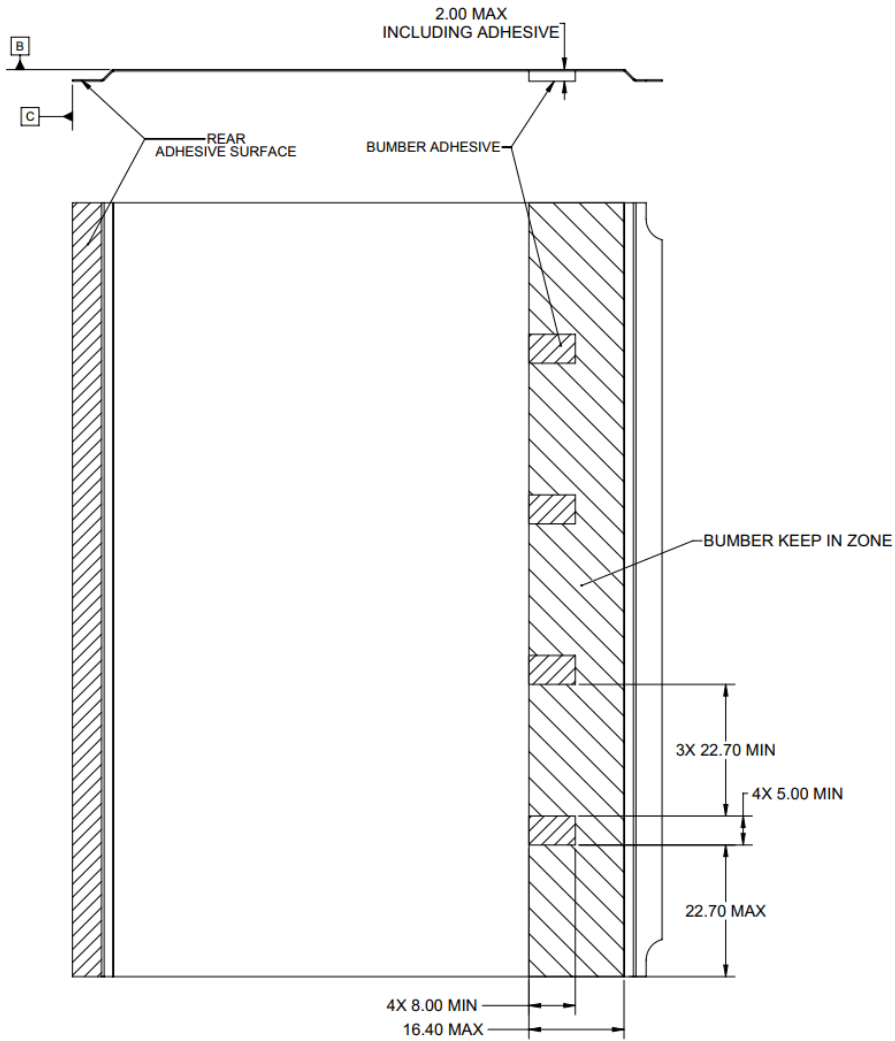

2.8 Critical-to-Function (CTF) Dimensions (SFF and LFF)

2.8.1 CTF Tolerances

The following CTF tolerances are used in this section and are the same for both the [small form factor](#) and [large form factor cards](#) SFF and LFF.

Table 98: CTF Default Tolerances (SFF and LFF OCP NIC 3.0)

CTF DEFAULT TOLERANCES	
DIMENSION RANGE	TOLERANCE
	TWO PLACE DECIMALS: X.XX
LINEAR:	± 0.30
ANGULAR:	± 1.00 DEGREES
HOLE DIAMETER:	± 0.13

2.8.2 SFF Pull Tab CTF Dimensions

The following dimensions are considered critical-to-function (CTF) for each [small form factor](#) SFF OCP NIC 3.0 card with a pull tab and thumbscrew. The CTF default tolerances are shown in Section 2.8.1.

Figure 4038: SFF OCP NIC 3.0 Card with Pull Tab CTF Dimensions (Top View)

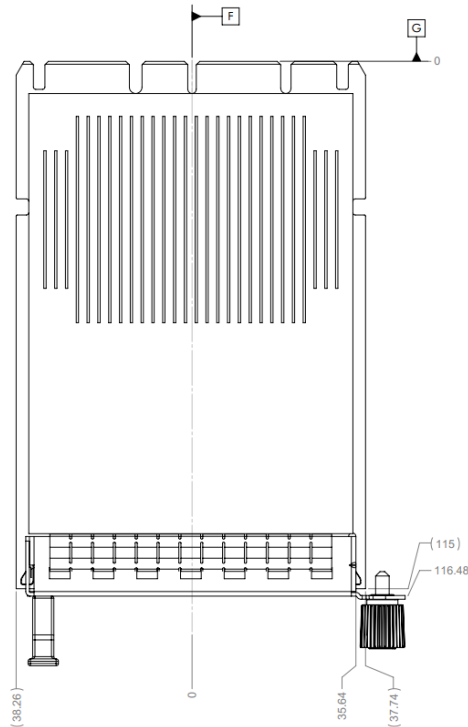

Figure 4139: SFF OCP NIC 3.0 Card with Pull Tab CTF Dimensions (Front View)

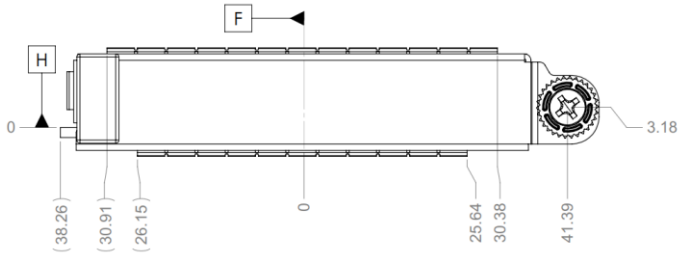
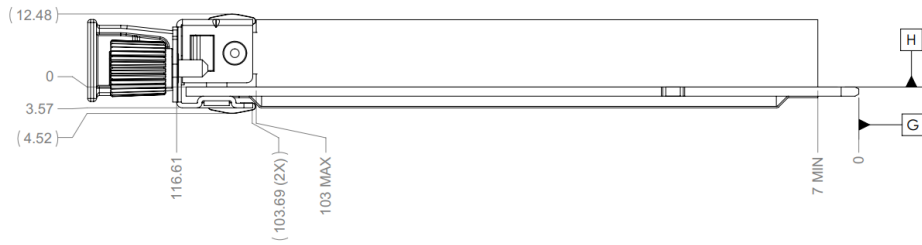

Figure 4240: SFF OCP NIC 3.0 Card with Pull Tab CTF Dimensions (Side View)



2.8.3 SFF OCP NIC 3.0 Card with Ejector Latch CTF Dimensions

The following dimensions are considered critical-to-function (CTF) for each [small form factor SFF](#) OCP NIC 3.0 card with ejector latch. The CTF default tolerances are shown in Section 2.8.1.

Figure [4344](#): SFF OCP NIC 3.0 Card with Ejector CTF Dimensions (Top View)

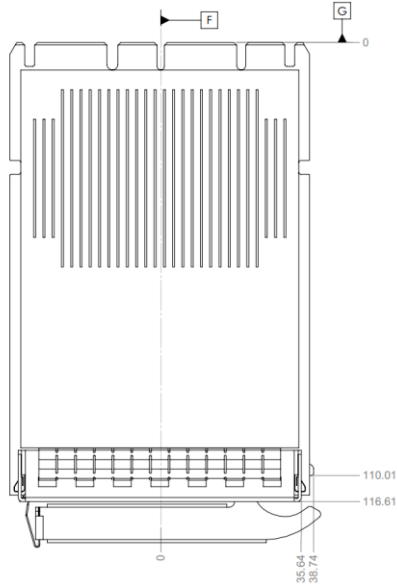

Figure [4442](#): SFF OCP NIC 3.0 Card with Ejector CTF Dimensions (Front View)

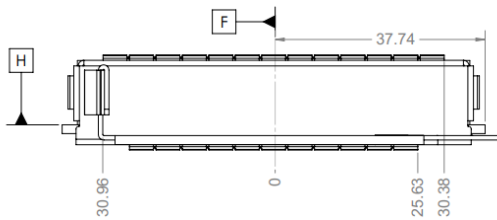
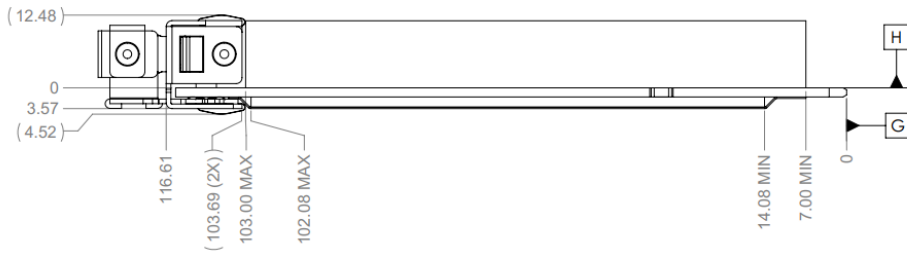

Figure [4543](#): SFF OCP NIC 3.0 Card with Ejector CTF Dimensions (Side View)



2.8.4 SFF OCP NIC 3.0 Baseboard CTF Dimensions

The following dimensions are considered critical-to-function (CTF) for each ~~small form factor~~SFF baseboard chassis. The CTF default tolerances are shown in Section 2.8.1.

Note: The SFF baseboard CTF dimensions are applicable to both the right angle and straddle mount connector configurations. The faceplate opening relative to the baseboard changes due to the connector vertical offset, but all CTF dimensions remain identical.

Figure 4644: SFF Baseboard Chassis CTF Dimensions (Rear View)

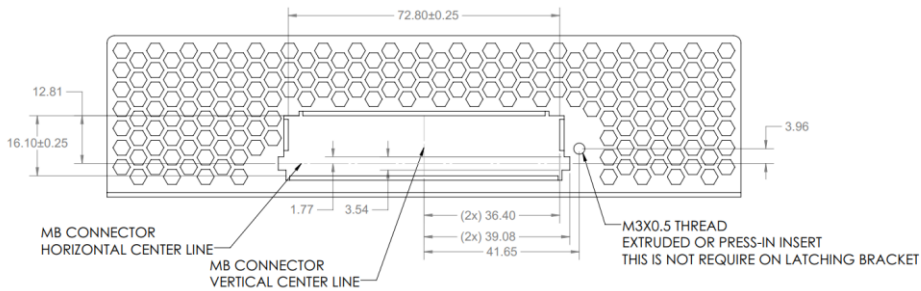

Figure 4745: SFF Baseboard Chassis to Card Thumb Screw CTF Dimensions (Side View)

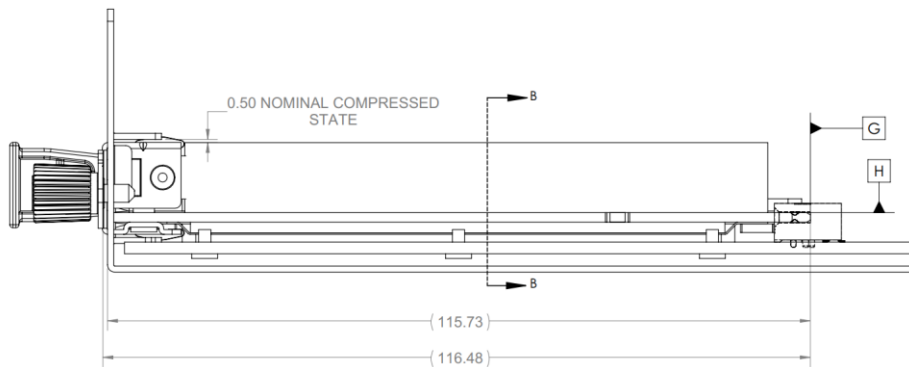

Figure 4846: SFF Baseboard Chassis to Ejector lever Card CTF Dimensions (Side View)

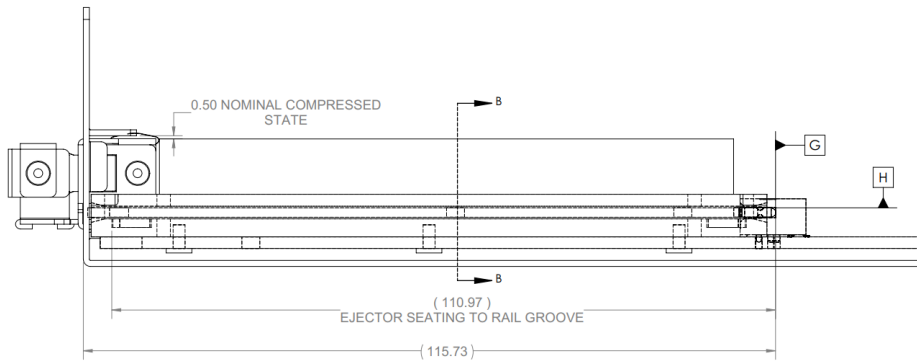

Figure 4947: SFF Baseboard Chassis CTF Dimensions (Rear Rail Guide View)

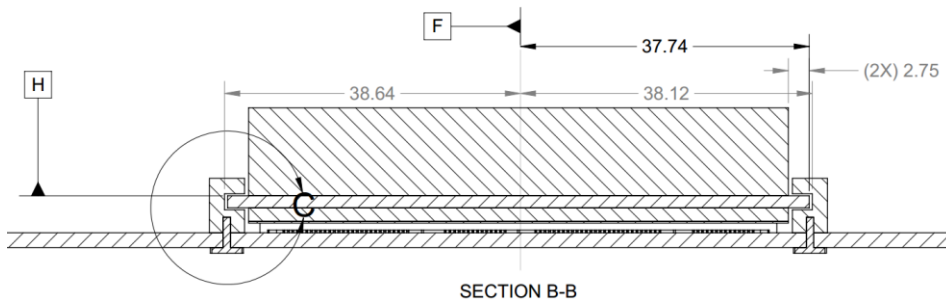
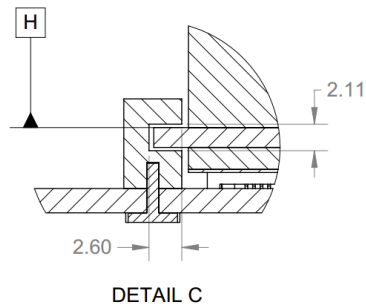

Figure 5048: SFF Baseboard Chassis CTF Dimensions (Rail Guide Detail) – Detail C



The right angle and straddle mount card guides are identical between the [Small and Large form factor SFF and LFF](#) cards. The card guide model is included in the 3D CAD packages and may be downloaded from the OCP NIC 3.0 Wiki site: <http://www.opencompute.org/wiki/Server/Mezz>.

2.8.5 LFF OCP NIC 3.0 Card CTF Dimensions

The following dimensions are considered critical-to-function (CTF) for each ~~large form factor~~LFF OCP NIC 3.0 card. The CTF default tolerances are shown in Section 2.8.1.

Figure ~~5149~~: LFF OCP NIC 3.0 Card with Ejector CTF Dimensions (Top View)

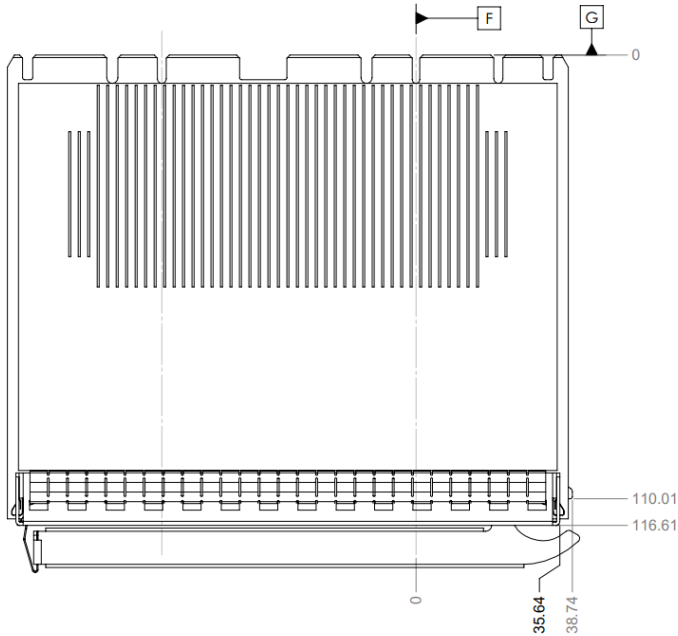

Figure ~~5250~~: LFF OCP NIC 3.0 Card with Ejector CTF Dimensions (Front View)

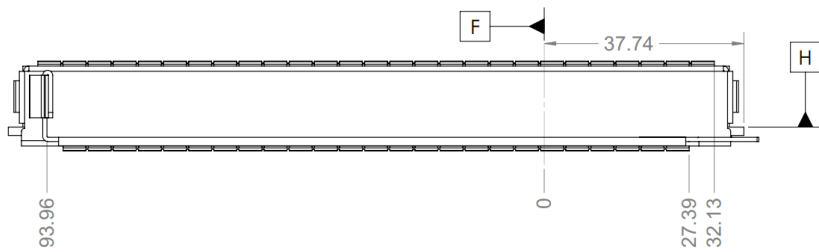
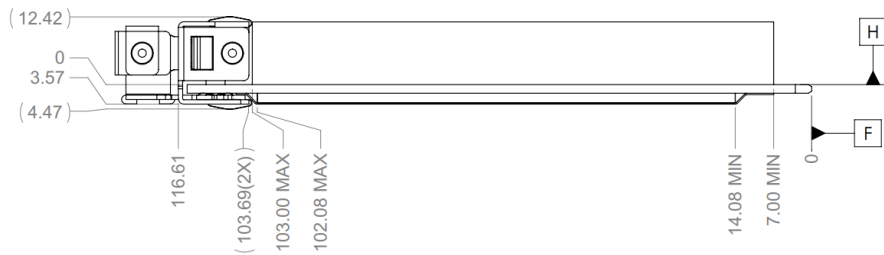

Figure 5351: LFF OCP NIC 3.0 Card with Ejector CTF Dimensions (Side View)



2.8.6 LFF OCP NIC 3.0 Baseboard CTF Dimensions

The following dimensions are considered critical-to-function (CTF) for each [large form factor LFF](#) baseboard chassis. The CTF default tolerances are shown in Section 2.8.1.

Note: The LFF baseboard CTF dimensions are applicable to both the right angle and straddle mount connector configurations. The faceplate opening relative to the baseboard changes due to the connector vertical offset, but all CTF dimensions remain identical.

Figure 5452: LFF Baseboard Chassis CTF Dimensions (Rear View)

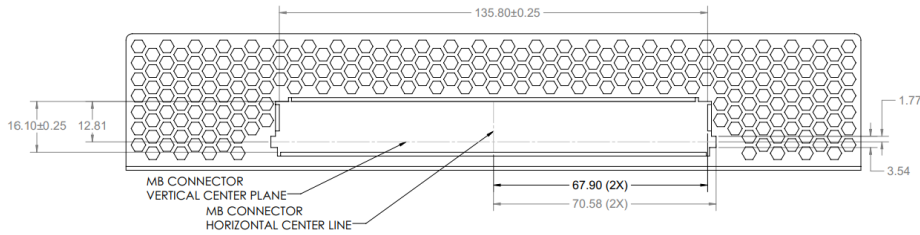

Figure [5553](#): LFF Baseboard Chassis CTF Dimensions (Side View)

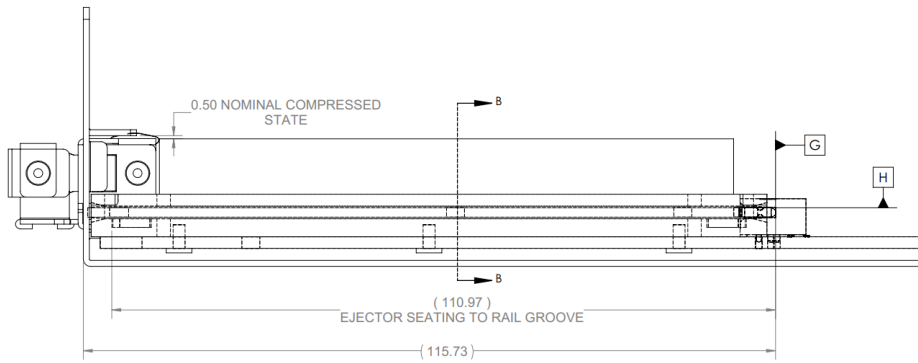
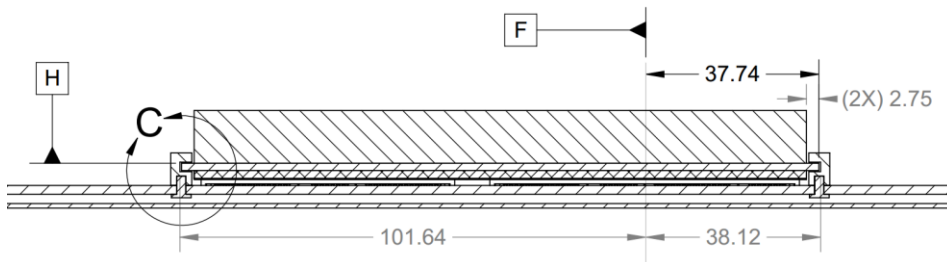
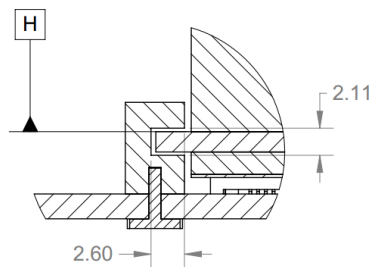

Figure [5654](#): LFF Baseboard Chassis CTF Dimensions (Rail Guide View)



SECTION B-B

Figure [5755](#): LFF Baseboard Chassis CTF Dimensions (Rail Guide – Detail C)



DETAIL C

The right angle and straddle mount card guides are identical between the [Small and Large form factor cards SFF and LFF](#). The card guide models are included in the 3D CAD packages and may be downloaded from the OCP NIC 3.0 Wiki site: <http://www.opencompute.org/wiki/Server/Mezz>.

2.9 Labeling Requirements

OCP NIC 3.0 cards shall implement all (or a subset of) label items listed below as required by each customer. All labels shall be placed on the exposed face of the insulator and within their designated zones. All labels shall be placed within the insulator edge and insulator bend lines to prevent labels from peeling or interfering with the faceplate, chassis card guides and card gold finger edge.

The insulator shall be divided into three different zones:

- **Regulatory Zone** – Used for all regulatory markings and filing numbers
- **Customer Zone** – Used for manufacturer markings or any ODM specific labels
- **OCP NIC 3.0 Zone** – Used for MAC addresses, part number labels and optionally the board serial number label if there are no manufacturer requirements to place it on the primary side

Notes:

- Some NIC vendor(s) may require serial number labels to be placed on the primary side of the PBA. This is permitted but it is up to the NIC vendor(s) to find the appropriate location(s) to affix the label. If a label is to be adhered to the PCB, then the label must be ESD safe as defined by ANSI/ESD S541-2008 (between 10^4 and 10^{11} Ohms).
- Regulatory marks may be printed on the insulator or affixed via a label
- Each zone size shall be adjustable to accommodate each vendor's labeling requirements
- All labels shall be oriented and readable in the same direction. The readable direction should be with the line side I/O interfaces facing "up"
- Additional labels may be placed on the primary side or on the PCB itself. This is up to the NIC vendor(s) to find the appropriate location(s)

Figure 5856: SFF Label Area Example

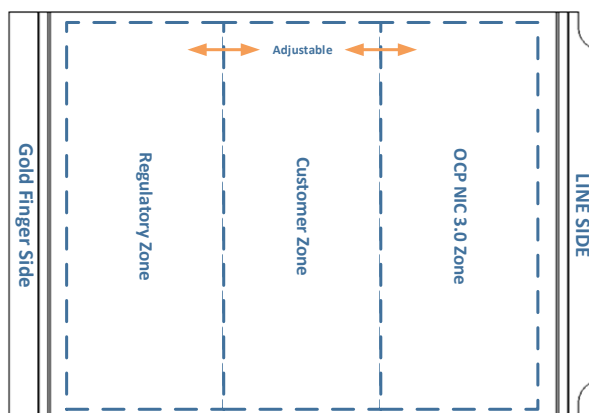

2.9.1 General Guidelines for Label Contents

Each board shall have a unique label for identification. The label information shall be both in human readable and machine readable formats (linear or 2D data matrix). The labels may include:

- Serial number
- Part Number
- MAC Address
- Manufacturing Date
- Manufacturing Site Information

Barcode Requirements

- Linear Barcodes
- Code 93, Code 128 Auto or Code 128 Subset B
- Minimum narrow bar width $X \geq 5_{\text{mil}}$ (0.127_{mm})
- 2D data matrix
- Data matrix shall use ECC200 error correction
- Minimum cell size $X \geq 10_{\text{mil}}$ (0.254_{mm})
- All linear barcode and data matrix labels shall meet the contrast and print growth requirements per ISO/IEC 16022
- All linear barcode and data matrix labels shall have a quality level C or higher per ISO/IER 15415
- All linear barcode and data matrix labels shall define a minimum Quiet Zone (QZ) to ensure the label is correctly registered by the scanner per ISO/IEC 15415
- Linear barcode labels shall use a QZ that is 10 times the width of the narrowest bar or 1/8th inch, whichever is greater.
- Data matrix labels shall have a Quiet Zone (QZ) that is at least one module (X dimension) around the perimeter of the data matrix.
- Multiple Serial Numbers, MAC address may exist in one 2D data matrix, each separated by a comma

Human Readable Font

- Arial or printer font equivalent
- Minimum 5 point font size. 3 point font is acceptable when using 600 DPI printers
- Text must be easily legible under normal lighting 6-to-8 inches away.

The label size and typeface may vary based on each vendor and/or customer's label content and requirements.

2.9.2 MAC Address Labeling Requirements

For an OCP NIC 3.0 card with m line side interfaces and n RBT management interfaces, the MAC address label shall list the MAC addresses in sequential order starting with line side port 1 to port m followed by the controller #0 MAC address to controller n . For cards that support multi-host configurations, the label shall associate each MAC address with a host number. The examples below show the MAC addresses presented as a single column, for labels with many MAC addresses, the label may also be formatted in multiple columns for greater readability.

2.9.2.1 MAC Address Label Example 1 – Quad Port with Single Host, Single Managed Controller

As an example, the label content of a quad SFP OCP NIC 3.0 card with a single management MAC address shall be constructed to show human readable data per the Label Data column of [Table 10](#)

Commented [NT1]: Is there a recommendation on how each MAC address is formatted in this comma delimited list? Thomas Ng + Johnathanh Mai to propose update

9. The constructed label is shown in [Figure 59](#)[Figure-57](#). For each human readable line, there is a MAC prefix “Px:” for a line side Port, or “MEx:” for a managed controller instance, followed by the MAC address. The port/controller association for each row is shown in the far right column.

Table 109: MAC Address Label Example 1 – Quad Port with Single Host, Single Managed Controller

Label Data	MAC Prefix	MAC Address	Association
P1: AA:BB:CC:DD:EE:F0	P1:	AA:BB:CC:DD:EE:F0	Port 1
P2: AA:BB:CC:DD:EE:F1	P2:	AA:BB:CC:DD:EE:F1	Port 2
P3: AA:BB:CC:DD:EE:F2	P3:	AA:BB:CC:DD:EE:F2	Port 3
P4: AA:BB:CC:DD:EE:F3	P4:	AA:BB:CC:DD:EE:F3	Port 4
ME1: AA:BB:CC:DD:EE:F4	ME1:	AA:BB:CC:DD:EE:F4	Controller #0

Figure 5957: MAC Address Label Example 1 – Quad Port with Single Host, Single Managed Controller

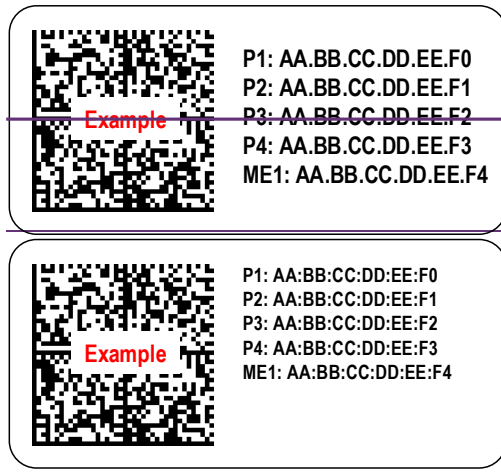

2.9.2.2 MAC Address Label Example 2 – Octal Port with Single Host, Dual Managed Controllers

As a second example, the label content of an octal port (2xQSFP with “breakout” support) OCP NIC 3.0 card with two managed silicon instances is constructed per [Table 11](#)[Table 40](#). The constructed label is shown in [Figure 60](#)[Figure-58](#). The MAC address label shall also list the four MAC addresses associated with QSFP lanes [1:4] for QSFP connectors that allow “breakout” modes. The Host-MAC address presentation may also be formatted horizontally for easier readability.

Table 1140: MAC Address Label Example 2 – Octal Port with Single Host, Dual Managed Controller

Label Data	MAC Prefix	MAC Address	Association
P1: AA:BB:CC:DD:EE:F0	P1:	AA:BB:CC:DD:EE:F0	QSFP1, Port 1
P2: AA:BB:CC:DD:EE:F1	P2:	AA:BB:CC:DD:EE:F1	QSFP1, Port 2
P3: AA:BB:CC:DD:EE:F2	P3:	AA:BB:CC:DD:EE:F2	QSFP1, Port 3
P4: AA:BB:CC:DD:EE:F3	P4:	AA:BB:CC:DD:EE:F3	QSFP1, Port 4
P5: AA:BB:CC:DD:EE:F4	P5:	AA:BB:CC:DD:EE:F4	QSFP2, Port 5
P6: AA:BB:CC:DD:EE:F5	P6:	AA:BB:CC:DD:EE:F5	QSFP2, Port 6

Open Compute Project • OCP NIC 3.0

Rev [0.840-83](#)

P7: AA:BB:CC:DD:EE:F6	P7:	AA:BB:CC:DD:EE:F6	QSFP2, Port 7
P8: AA:BB:CC:DD:EE:F7	P8:	AA:BB:CC:DD:EE:F7	QSFP2, Port 8
ME1: AA:BB:CC:DD:EE:F8	ME1:	AA:BB:CC:DD:EE:F8	Controller #0
ME2: AA:BB:CC:DD:EE:F9	ME2:	AA:BB:CC:DD:EE:F9	Controller #1

Figure 6058: MAC Address Label Example 2 – Octal Port with Single Host, Dual Managed Controller

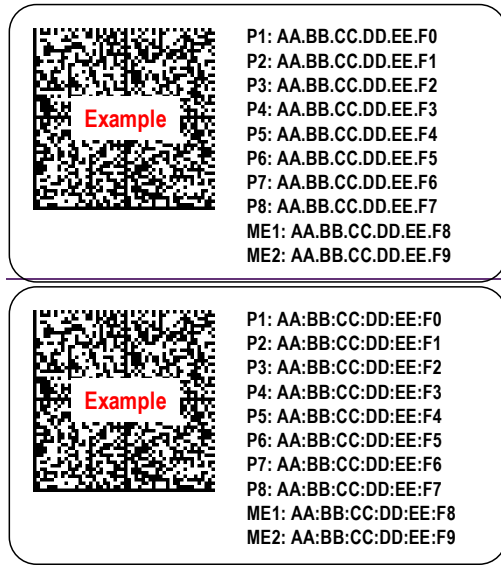

2.9.2.3 MAC Address Label Example 3 – Quad Port with Dual Hosts, Dual Managed Controllers

For multi-host implementations, each MAC address shall be prefixed with the host association “Hx” prior to the port number, where x represents the host number. An example of this is shown in [Table 12](#) and [Figure 61](#).

Table 1244: MAC Address Label Example 3 – Quad Port with Dual Hosts, Dual Managed Controller

Label Data	Host	MAC Prefix	MAC Address	Association
P1: AA:BB:CC:DD:EE:F0	H1	P1:	AA:BB:CC:DD:EE:F0	Port 1
P2: AA:BB:CC:DD:EE:F1	H1	P2:	AA:BB:CC:DD:EE:F1	Port 2
P3: AA:BB:CC:DD:EE:F2	H2	P3:	AA:BB:CC:DD:EE:F2	Port 3
P4: AA:BB:CC:DD:EE:F3	H2	P4:	AA:BB:CC:DD:EE:F3	Port 4
ME1: AA:BB:CC:DD:EE:F4	n/a	ME1:	AA:BB:CC:DD:EE:F4	Controller #0
ME2: AA:BB:CC:DD:EE:F5	n/a	ME2:	AA:BB:CC:DD:EE:F5	Controller #1

Figure 6159: MAC Address Label Example 3 – Quad Port with Dual Hosts, Dual Managed Controllers

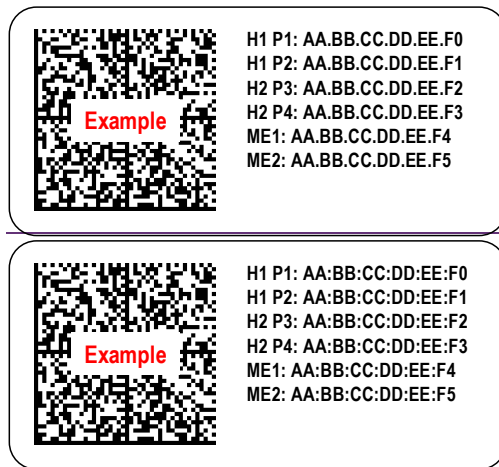

2.9.2.4 MAC Address Label Example 4 – Single Port with Quad Host, Single Managed Controller

The following example shows a single port device with quad hosts. To conserve space on the MAC address label, this example only shows the MAC addresses for Port 1 through Port 4. The MAC address for each managed host is P_x+1. This is shown in [Table 13](#) and [Figure 62](#).

Table 1342: MAC Address Label Example 4 – Single Port with Quad Host, Single Managed Controller

Label Data	Host	MAC Prefix	MAC Address	Association
P1: AA:BB:CC:DD:EE:F0	H1	P1:	AA:BB:CC:DD:EE:F0	Port 1
ME1: AA:BB:CC:DD:EE:F1	ME1	P1:	AA:BB:CC:DD:EE:F1	Port 1
P2: AA:BB:CC:DD:EE:F2	H2	P1:	AA:BB:CC:DD:EE:F2	Port 1
ME2: AA:BB:CC:DD:EE:F3	ME2	P1:	AA:BB:CC:DD:EE:F3	Port 1
P3: AA:BB:CC:DD:EE:F4	H3	P1:	AA:BB:CC:DD:EE:F4	Port 1
ME3: AA:BB:CC:DD:EE:F5	ME3	P1:	AA:BB:CC:DD:EE:F5	Port 1
P4: AA:BB:CC:DD:EE:F6	H4	P1:	AA:BB:CC:DD:EE:F6	Port 1
ME4: AA:BB:CC:DD:EE:F7	ME4	P1:	AA:BB:CC:DD:EE:F7	Port 1

Figure 6260: MAC Address Label Example 4 – Single Port with Quad Host, Single Managed Controller

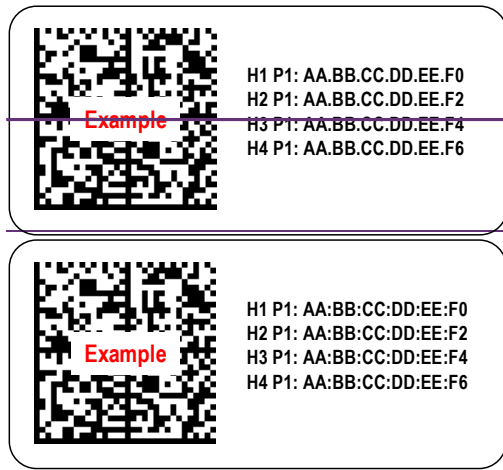

2.10 Mechanical CAD Package Examples

Typical OCP NIC 3.0 implementation examples are included in the 3D CAD package. The purpose of these examples is to demonstrate the implementation feasibility. Additional use cases beyond the implementation examples are possible as long they adhere to the OCP NIC 3.0 specification.

Note: For brevity, references to QSFP+, and QSFP28 shall be referred to as QSFP in this document. Similarly, references to SFP+, and SFP28 shall be referred to as SFP.

The 3D CAD files may be obtained from the OCP NIC 3.0 Wiki:
<http://www.opencompute.org/wiki/Server/Mezz>

Table ~~1413~~: NIC Implementation Examples and 3D CAD

Implementation Example	3D CAD File name
Small form factor SFF Single/Dual QSFP ports	01_nic_v3_sff2q_1tab_asm.stp 01_nic_v3_sff2q_latch_asm.stp
Small form factor SFF Single/Dual SFP ports	N/A
Small form factor SFF Quad SFP ports	01_nic_v3_sff4s_1tab_asm.stp 01_nic_v3_sff4s_latch_asm.stp
Small form factor SFF Quad 10GBASE-T ports	01_nic_v3_sff4r_1tab_asm.stp 01_nic_v3_sff4r_latch_asm.stp
Large form factor LFF Single/Dual QSFP ports	01_nic_v3_lff2q_asm.stp
Large form factor LFF Single/Dual SFP ports	N/A
Large form factor LFF Quad SFP ports	01_nic_v3_lff4s_asm.stp
Large form factor LFF Quad 10GBASE-T ports	01_nic_v3_lff4r_asm.stp

3 Electrical Interface Definition – Card Edge and Baseboard

3.1 Card Edge Gold Finger Requirements

The OCP NIC 3.0 cards are compliant to the SFF-TA-1002 specification with respect to the gold fingers and connectors.

[Small-SizeSFF](#) cards fit in the Primary Connector. Primary Connector compliant cards are 76 mm x 115 mm and may implement the full 168-pins. The Primary Connector cards may optionally implement a subset of gold finger pins if there is a reduced PCIe width requirement (such as 1 x8 and below). In this case, the card edge gold finger may implement a 2C+ design. The overall board thickness is 1.57 mm. The gold finger dimensions for the Primary Connector compliant cards are shown below.

[Large-SizeLFF Cards-cards](#) support up to a x32 PCIe implementation and may use both the Primary 4C+ and Secondary (4C) Connectors. [Large-SizeLFF Cards-cards](#) may implement a reduced PCIe lane count and optionally implement only the Primary Connector 4C+, or 2C OCP bay.

Note: The “B” pins on the connector are associated with the top side of the OCP NIC 3.0 card. The “A” pins on the connector are associated with the bottom side of the OCP NIC 3.0 card. The A and B side pins are physically on top of each other with zero x-axis offset.

Figure 6364: SFF Primary Connector Gold Finger Dimensions – x16 – Top Side (“B” Pins)

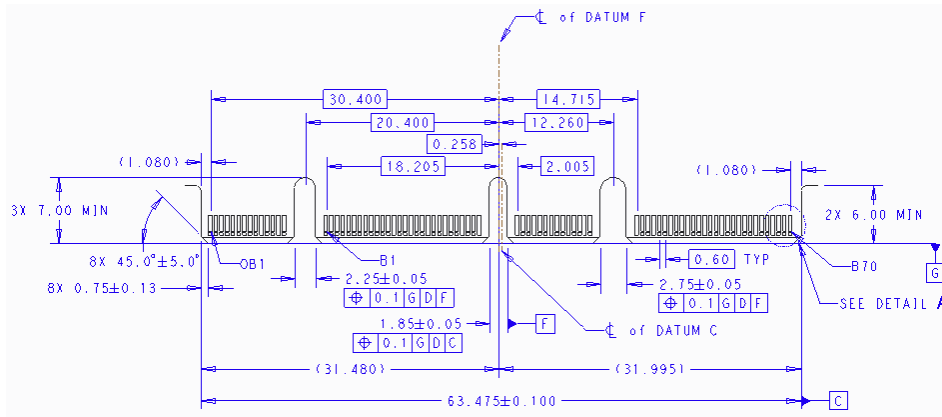

Figure 6462: LFF Gold Finger Dimensions – x32 – Top Side (“B” Pins)

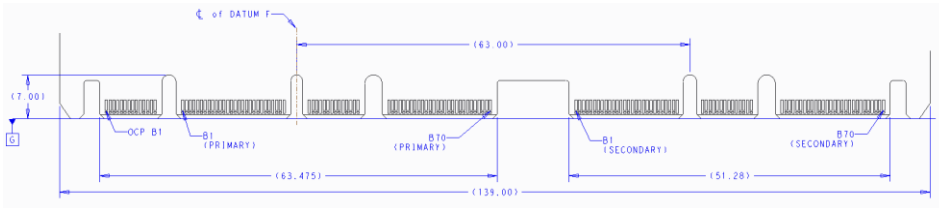
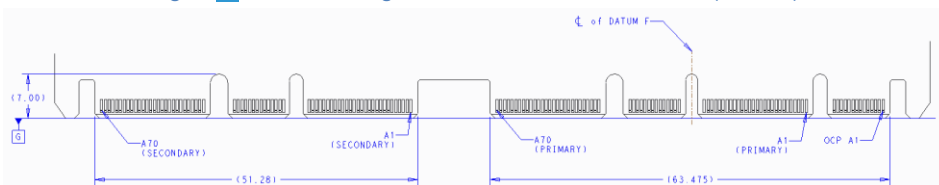

Figure 6563: LFF Gold Finger Dimensions – x32 – Bottom Side (“A” Pins)



3.1.1 Gold Finger Mating Sequence

Per the SFF-TA-1002 specification, the Primary and Secondary Connectors are protocol agnostic and are optimized for high speed differential pairs. For use in the OCP NIC 3.0 application, some pin locations are used for single ended control nets or power and would benefit from a shorter pin length for staggering. As such, the required OCP NIC 3.0 card gold finger staging is shown in [Table 15Table 14](#) for a two stage, first-mate, last-break functionality. The two-stage finger length is a normative requirement for the OCP NIC 3.0 card. The host connectors have a single stage mating and do not implement different pin lengths.

The AIC Plug (Free) side refers to the OCP NIC 3.0 card gold fingers; the receptacle (Fixed) side refers to the physical connector on the host platform. This table is based on the SFF-TA-1002 Table A-1 with modifications for OCP NIC 3.0. Refer to the mechanical drawings for pin the first-mate and second-mate lengths.

Note: Pin names in [Table 15Table 14](#) and [Table 16Table 15](#) are used for first mate/second mate reference only. Full pin definitions are described in Sections 3.3 and 3.4.

Table 1544: Contact Mating Positions for the Primary Connector

Side B			Side A			
Gold Finger Side (Free)		Receptacle (Fixed)	Gold Finger Side (Free)		Receptacle (Fixed)	
2 nd Mate	1 st Mate		2 nd Mate	1 st Mate		
OCP B1	NIC_PWR_GOOD		OCP A1	PERST2#		
OCP B2	MAIN_PWR_EN		OCP A2	PERST3#		
OCP B3	LD#		OCP A3	WAKE#		
OCP B4	DATA_IN		OCP A4	RBT_ARB_IN		
OCP B5	DATA_OUT		OCP A5	RBT_ARB_OUT		
OCP B6	CLK		OCP A6	SLOT_ID1		
OCP B7	SLOT_ID0		OCP A7	RBT_TX_EN		
OCP B8	RBT_RXD1		OCP A8	RBT_TXD1		
OCP B9	RBT_RXD0		OCP A9	RBT_TXD0		
OCP B10	GND		OCP A10	GND		
OCP B11	REFCLKn2		OCP A11	REFCLKn3		
OCP B12	REFCLKp2		OCP A12	REFCLKp3		

OCP B13	GND		OCP A13	GND
OCP B14	RBT CRS DV		OCP A14	RBT CLK IN
Mechanical Key				
B1	+12V_EDGE		A1	GND
B2	+12V_EDGE		A2	GND
B3	+12V_EDGE		A3	GND
B4	+12V_EDGE		A4	GND
B5	+12V_EDGE		A5	GND
B6	+12V_EDGE		A6	GND
B7	BIF0#		A7	SMCLK
B8	BIF1#		A8	SMDAT
B9	BIF2#		A9	SMRST#
B10	PERST0#		A10	PRNSTA#
B11	+3.3V_EDGE		A11	PERST1#
B12	AUX_PWR_EN		A12	PRNSTB2#
B13	GND		A13	GND
B14	REFCLKn0		A14	REFCLKn1
B15	REFCLKp0		A15	REFCLKp1
B16	GND		A16	GND
B17	PETn0		A17	PERn0
B18	PETp0		A18	PERp0
B19	GND		A19	GND
B20	PETn1		A20	PERn1
B21	PETp1		A21	PERp1
B22	GND		A22	GND
B23	PETn2		A23	PERn2
B24	PETp2		A24	PERp2
B25	GND		A25	GND
B26	PETn3		A26	PERn3
B27	PETp3		A27	PERp3
B28	GND		A28	GND
Mechanical Key				
B29	GND		A29	GND
B30	PETn4		A30	PERn4
B31	PETp4		A31	PERp4
B32	GND		A32	GND
B33	PETn5		A33	PERn5
B34	PETp5		A34	PERp5
B35	GND		A35	GND
B36	PETn6		A36	PERn6
B37	PETp6		A37	PERp6
B38	GND		A38	GND
B39	PETn7		A39	PERn7
B40	PETp7		A40	PERp7
B41	GND		A41	GND
B42	PRSNB0#		A42	PRSNB1#
Mechanical Key				
B43	GND		A43	GND
B44	PETn8		A44	PERn8
B45	PETp8		A45	PERp8
B46	GND		A46	GND
B47	PETn9		A47	PERn9
B48	PETp9		A48	PERp9
B49	GND		A49	GND
B50	PETn10		A50	PERn10
B51	PETp10		A51	PERp10
B52	GND		A52	GND
B53	PETn11		A53	PERn11
B54	PETp11		A54	PERp11
B55	GND		A55	GND
B56	PETn12		A56	PERn12
B57	PETp12		A57	PERp12
B58	GND		A58	GND
B59	PETn13		A59	PERn13
B60	PETp13		A60	PERp13
B61	GND		A61	GND
B62	PETn14		A62	PERn14
B63	PETp14		A63	PERp14
B64	GND		A64	GND
B65	PETn15		A65	PERn15
B66	PETp15		A66	PERp15

B67	GND		A67	GND
B68	RFU1, N/C		A68	USB_DATn
B69	RFU2, N/C		A69	USB_DATp
B70	PRSNB3#		A70	PWRBRK#

Table 1645: Contact Mating Positions for the Secondary Connector

Side B			Side A		
Gold Finger Side (Free)		Receptacle (Fixed)	Gold Finger Side (Free)		Receptacle (Fixed)
2 nd Mate	1 st Mate		2 nd Mate	1 st Mate	
B1	+12V_EDGE		A1	GND	
B2	+12V_EDGE		A2	GND	
B3	+12V_EDGE		A3	GND	
B4	+12V_EDGE		A4	GND	
B5	+12V_EDGE		A5	GND	
B6	+12V_EDGE		A6	GND	
B7	BIFO#		A7	SMCLK	
B8	BIF1#		A8	SMDAT	
B9	BIF2#		A9	SMRST#	
B10	PRST0#		A10	PRNSTA#	
B11	+3.3V_EDGE		A11	PERST0#	
B12	AUX_PWR_EN		A12	PRSNB2#	
B13	GND		A13	GND	
B14	REFCLKn0		A14	REFCLKn5	
B15	REFCLKp0		A15	REFCLKp5	
B16	GND		A16	GND	
B17	PETn00		A17	PERn00	
B18	PETp00		A18	PERp00	
B19	GND		A19	GND	
B20	PETn17		A20	PERn17	
B21	PETp17		A21	PERp17	
B22	GND		A22	GND	
B23	PETn82		A23	PERn82	
B24	PETp82		A24	PERp82	
B25	GND		A25	GND	
B26	PETn93		A26	PERn93	
B27	PETp93		A27	PERp93	
B28	GND		A28	GND	
Mechanical Key					
B29	GND		A29	GND	
B30	PETn20		A30	PERn20	
B31	PETp04		A31	PERp04	
B32	GND		A32	GND	
B33	PETn15		A33	PERn15	
B34	PETp15		A34	PERp15	
B35	GND		A35	GND	
B36	PETn26		A36	PERn26	
B37	PETp26		A37	PERp26	
B38	GND		A38	GND	
B39	PETn37		A39	PERn37	
B40	PETp37		A40	PERp37	
B41	GND		A41	GND	
B42	PRSNB0#		A42	PRSNB1#	
Mechanical Key					
B43	GND		A43	GND	
B44	PETn48		A44	PERn48	
B45	PETp48		A45	PERp48	
B46	GND		A46	GND	
B47	PETn59		A47	PERn59	
B48	PETp59		A48	PERp59	
B49	GND		A49	GND	
B50	PETn60		A50	PERn60	
B51	PETp60		A51	PERp60	
B52	GND		A52	GND	
B53	PETn71		A53	PERn71	
B54	PETp71		A54	PERp71	
B55	GND		A55	GND	
B56	PETn81		A56	PERn81	
B57	PETp81		A57	PERp81	
B58	GND		A58	GND	

Open Compute Project • OCP NIC 3.0

Rev ~~0.840-83~~

B59	PETn 014		A59	PERn 014	
B60	PETp 014		A60	PERp 014	
B61	GND		A61	GND	
B62	PETn 014		A62	PERn 014	
B63	PETp 014		A63	PERp 014	
B64	GND		A64	GND	
B65	PETn 114		A65	PERn 114	
B66	PETp 114		A66	PERp 114	
B67	GND		A67	GND	
B68	RFU 1 , N/C		A68	UART_RX	
B69	RFU 2 , N/C		A69	UART_TX	
B70	PRSNB3#		A70	PWRBRK_#	

3.2 Baseboard Connector Requirements

The OCP NIC 3.0 connectors are compliant to the “4C+” and “4C” connectors as defined in the SFF-TA-1002 specification for a right angle or straddle mount form_factor. The Primary Connector is a 4C+ implementation with 168-pins. The Secondary Connector is a 4C implementation with 140-pins. Both the Primary and Secondary Connectors includes support for up to 32 differential pairs to support a x16 PCIe connection. Each connector also provides 6 pins of +12V_EDGE, and 1 pin of +3.3V_EDGE for power. This implementation is common between both the Primary and Secondary Connectors. In addition, the 4C+ implementation of the Primary Connector has a 28-pin OCP Bay used for management and support for up to a 4 x2 and 4 x4 multi-host configuration on the Primary Connector. The Primary and Secondary Connector drawings are shown below.

All diagram units are in mm unless otherwise noted.

3.2.1 Right Angle Connector

The following offset and height options are available for the right angle Primary and Secondary Connectors.

Table 1746: Right Angle Connector Options

Name	Pins	Style and Baseboard Thickness	Offset (mm)
Primary Connector – 4C+	168 pins	Right Angle	4.05 mm
Secondary Connector – 4C	140 pins	Right Angle	4.05 mm

Figure 6664: 168-pin Base Board Primary Connector – Right Angle

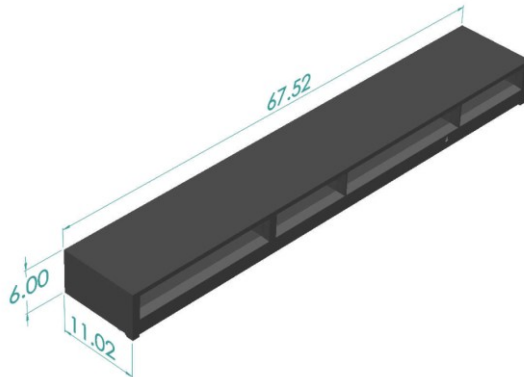
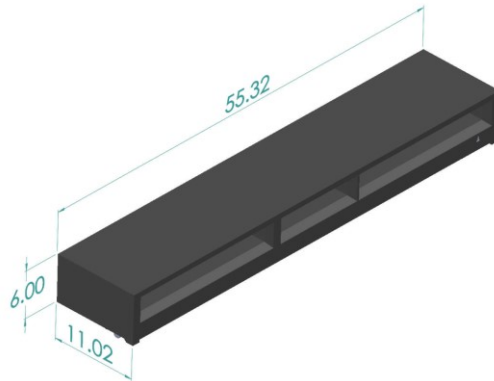

Figure [6765](#): 140-pin Base Board Secondary Connector – Right Angle



3.2.2 Right Angle Offset

The OCP NIC 3.0 right angle connectors have a 4.05 mm offset from the baseboard (pending SI simulation results). This is shown in [Figure 68](#) ~~Figure-66~~.

Figure [6866](#): OCP NIC 3.0 Card and Host Offset for Right Angle Connectors

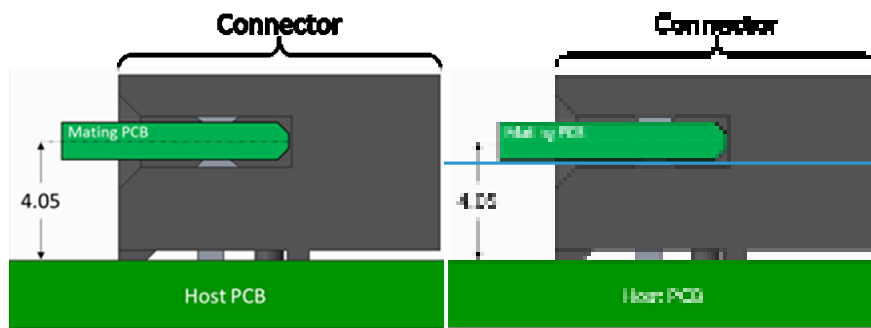

3.2.3 Straddle Mount Connector

The following offset and height options are available for the straddle mount Primary and Secondary Connectors.

Table [1817](#): Straddle Mount Connector Options

Name	Pins	Style and Baseboard Thickness	Offset (mm)
Primary Connector – 4C+	168 pins	Straddle Mount for 0.062"	Coplanar (0 mm)
Primary Connector – 4C+	168 pins	Straddle Mount for 0.076"	-0.3 mm
Primary Connector – 4C+	168 pins	Straddle Mount for 0.093"	Coplanar (0 mm)
Secondary Connector – 4C	140 pins	Straddle Mount for 0.062"	Coplanar (0 mm)

Secondary Connector – 4C	140 pins	Straddle Mount for 0.076"	-0.3 mm
Secondary Connector – 4C	140 pins	Straddle Mount for 0.093"	Coplanar (0 mm)

Figure [6967](#): 168-pin Base Board Primary Connector – Straddle Mount

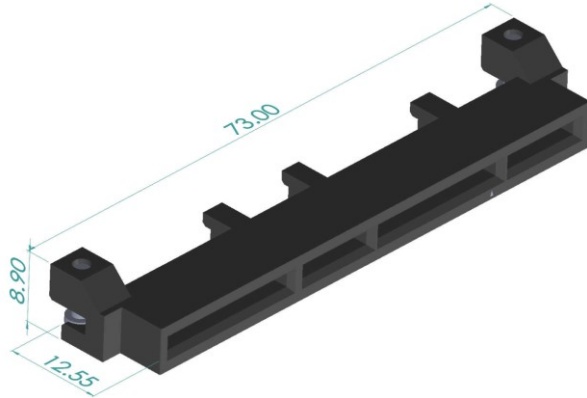
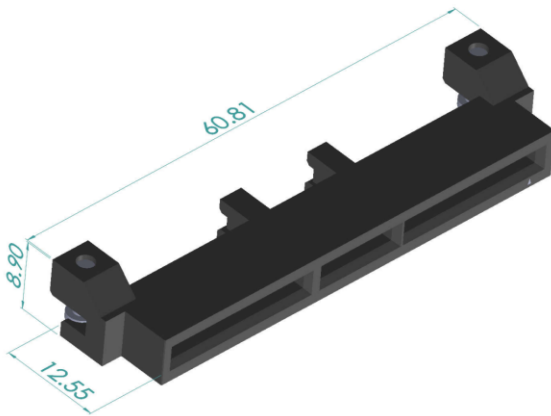

Figure [7068](#): 140-pin Base Board Secondary Connector – Straddle Mount



3.2.4 Straddle Mount Offset and PCB Thickness Options

The OCP NIC 3.0 straddle mount connectors have three baseboard PCB thicknesses they can accept. The available options are shown in [Figure 71](#)[Figure-69](#). The thicknesses are 0.062", 0.076", and 0.093". These PCBs must be controlled to a thickness of $\pm 10\%$. These are available for both the Primary and Secondary Connector locations. At the time of this writing, the most commonly used part is expected to be the 0.076" baseboard thickness.

Figure [71](#)[69](#): OCP NIC 3.0 Card and Baseboard PCB Thickness Options for Straddle Mount Connectors

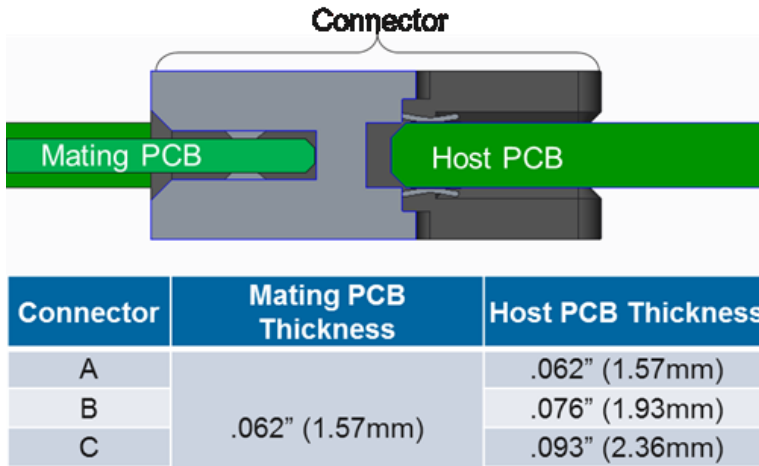

The connectors are capable of being used coplanar as shown in [Figure 72](#)[Figure-70](#). Additionally, the connectors are also capable of having a 0.3 mm offset from the centerline of the host board as shown in [Figure 73](#)[Figure-71](#).

Figure [72](#)[70](#): 0 mm Offset (Coplanar) for 0.062" Thick Baseboards

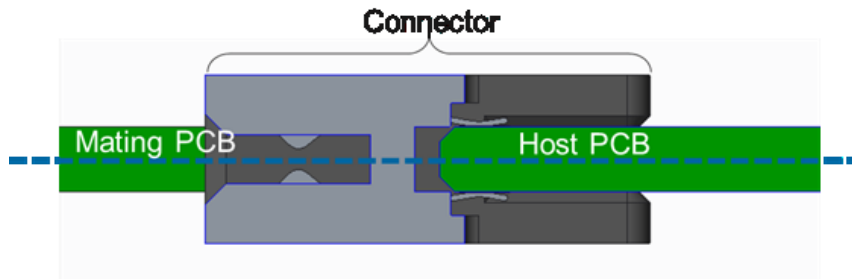
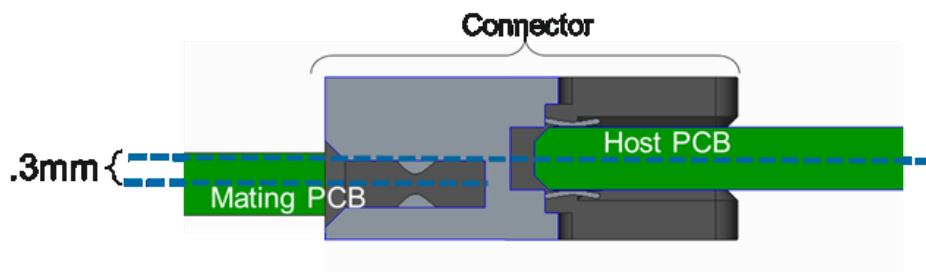

Figure 7374: 0.3mm Offset for 0.076" Thick Baseboards



3.2.5 LFF Connector Locations

In order to support the [large form factor LFF](#), systems must locate the Primary and Secondary Connectors per the mechanical drawing shown in [Figure 74](#) [Figure 72](#) and [Figure 75](#) [Figure 73](#).

Figure 7472: Primary and Secondary Connector Locations for LFF Support with Right Angle Connectors

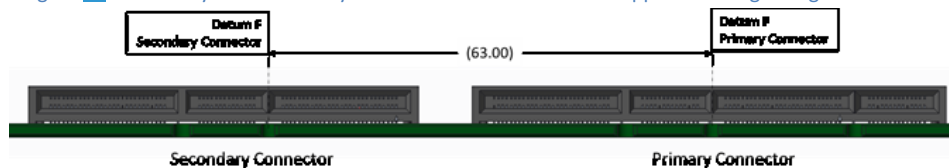
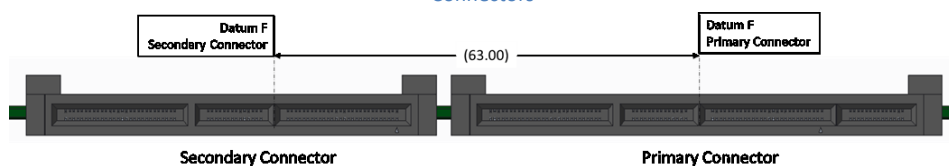

Figure 7573: Primary and Secondary Connector Locations for LFF Support with Straddle Mount Connectors



3.3 Pin Definition

The pin definitions of an OCP NIC 3.0 card with up to a x32 PCIe interface are shown in [Table 19](#) [Table 18](#) and [Table 20](#) [Table 19](#). All signal directions are shown from the perspective of the baseboard.

A baseboard system may provide a combination of Primary Connectors only, or Primary and Secondary Connectors to support multiple sizes of OCP NIC 3.0 cards. Both connectors share common functionality with power, SMBus 2.0, x16 PCIe and bifurcation control. The Primary Connector 4C+ definition has an additional OCP Bay (pins OCP_A[1:14], OCP_B[1:14]) with additional REFCLKs for supporting up to four PCIe hosts, NC-SI over RBT connectivity and a Scan Chain for information exchange between the host and card. The NIC is required to implement the Scan Chain, while the baseboard may choose to optionally implement it. Depending on the baseboard form factor, multiple OCP NIC 3.0 compliant cards may be designed into the system.

The ~~pins common to the~~ Primary and Secondary Connectors pins are shown in Section 3.4. The OCP Bay pins on the Primary Connector only are explicitly called out with the ~~prefix~~ “OCP_” ~~prefix in the~~ pin location column.

Cards or systems that do not require the use of a PCIe x16 connection may optionally implement a subset of electrical connections as applicable to the design. For example, a x8 (or smaller) card using the first 8 PCIe lanes that is compliant with the Primary Connector pinout. Refer to Sections 3.1 and 3.2 for mechanical details. For these cases, the Primary Connector matches the 2C dimensions as defined in SFF-TA-1002.

In all cases, the physical baseboard connectors shall support x16 PCIe widths and must be implemented with the Primary (4C+) and Secondary (4C) connectors.

3.3.1 Primary Connector

Table 1948: Primary Connector Pin Definition (x16) (4C+)

Side B		Side A	
OCP_B1	NIC_PWR_GOOD	PERST2#	OCP_A1
OCP_B2	MAIN_PWR_EN	PERST3#	OCP_A2
OCP_B3	LD#	WAKE#	OCP_A3
OCP_B4	DATA_IN	RBT_ARB_IN	OCP_A4
OCP_B5	DATA_OUT	RBT_ARB_OUT	OCP_A5
OCP_B6	CLK	SLOT_ID1	OCP_A6
OCP_B7	SLOT_ID0	RBT_TX_EN	OCP_A7
OCP_B8	RBT_RXD1	RBT_TXD1	OCP_A8
OCP_B9	RBT_RXD0	RBT_TXD0	OCP_A9
OCP_B10	GND	GND	OCP_A10
OCP_B11	REFCLKn2	REFCLKn3	OCP_A11
OCP_B12	REFCLKp2	REFCLKp3	OCP_A12
OCP_B13	GND	GND	OCP_A13
OCP_B14	RBT_CRS_DV	RBT_CLK_IN	OCP_A14
Mechanical Key			
B1	+12V_EDGE	GND	A1
B2	+12V_EDGE	GND	A2
B3	+12V_EDGE	GND	A3
B4	+12V_EDGE	GND	A4
B5	+12V_EDGE	GND	A5
B6	+12V_EDGE	GND	A6
B7	BIF0#	SMCLK	A7
B8	BIF1#	SMDAT	A8
B9	BIF2#	SMRST#	A9
B10	PERST0#	PRSNTA#	A10
B11	+3.3V_EDGE	PERST1#	A11
B12	AUX_PWR_EN	PRSNB2#	A12
B13	GND	GND	A13
B14	REFCLKn0	REFCLKn1	A14
B15	REFCLKp0	REFCLKp1	A15
B16	GND	GND	A16
B17	PETn0	PERn0	A17
B18	PETp0	PERp0	A18
B19	GND	GND	A19
B20	PETn1	PERn1	A20
B21	PETp1	PERp1	A21

Primary Connector (4C+, x16, 168-pin OCP NIC 3.0 card with OCP Bay)

Primary Connector (2C+, x8, 112-pin OCP NIC 3.0 card with OCP Bay)

B22	GND	GND	A22
B23	PETn2	PERn2	A23
B24	PETp2	PERp2	A24
B25	GND	GND	A25
B26	PETn3	PERn3	A26
B27	PETp3	PERp3	A27
B28	GND	GND	A28
Mechanical Key			
B29	GND	GND	A29
B30	PETn4	PERn4	A30
B31	PETp4	PERp4	A31
B32	GND	GND	A32
B33	PETn5	PERn5	A33
B34	PETp5	PERp5	A34
B35	GND	GND	A35
B36	PETn6	PERn6	A36
B37	PETp6	PERp6	A37
B38	GND	GND	A38
B39	PETn7	PERn7	A39
B40	PETp7	PERp7	A40
B41	GND	GND	A41
B42	PRSNB0#	PRSNB1#	A42
Mechanical Key			
B43	GND	GND	A43
B44	PETn8	PERn8	A44
B45	PETp8	PERp8	A45
B46	GND	GND	A46
B47	PETn9	PERn9	A47
B48	PETp9	PERp9	A48
B49	GND	GND	A49
B50	PETn10	PERn10	A50
B51	PETp10	PERp10	A51
B52	GND	GND	A52
B53	PETn11	PERn11	A53
B54	PETp11	PERp11	A54
B55	GND	GND	A55
B56	PETn12	PERn12	A56
B57	PETp12	PERp12	A57
B58	GND	GND	A58
B59	PETn13	PERn13	A59
B60	PETp13	PERp13	A60
B61	GND	GND	A61
B62	PETn14	PERn14	A62
B63	PETp14	PERp14	A63
B64	GND	GND	A64
B65	PETn15	PERn15	A65
B66	PETp15	PERp15	A66
B67	GND	GND	A67
B68	RFU1, N/C	USB_DATn	A68
B69	RFU2, N/C	USB_DATp	A69
B70	PRSNB3#	PWRBRK0#	A70

3.3.2 Secondary Connector

Table ~~2019~~: Secondary Connector Pin Definition (x16) (4C)

Side B		Side A	
B1	+12V_EDGE	GND	A1
B2	+12V_EDGE	GND	A2
B3	+12V_EDGE	GND	A3
B4	+12V_EDGE	GND	A4
B5	+12V_EDGE	GND	A5
B6	+12V_EDGE	GND	A6
B7	BIFO#	SMCLK	A7
B8	BIF1#	SMDAT	A8
B9	BIF2#	SMRST#	A9
B10	PRSTP PRST#	PRSNTA#	A10
B11	+3.3V_EDGE	PERn PERST#	A11
B12	AUX_PWR_EN	PRSNTB2#	A12
B13	GND	GND	A13
B14	REFCLKn 46	REFCLKn 54	A14
B15	REFCLKp 46	REFCLKp 54	A15
B16	GND	GND	A16
B17	PETn 160	PERn 916	A17
B18	PETp 160	PERp 916	A18
B19	GND	GND	A19
B20	PETn 17	PERn 174	A20
B21	PETp 17	PERp 174	A21
B22	GND	GND	A22
B23	PETn 182	PERn 182	A23
B24	PETp 182	PERp 182	A24
B25	GND	GND	A25
B26	PETn 193	PERn 193	A26
B27	PETp 193	PERp 193	A27
B28	GND	GND	A28
Mechanical Key			
B29	GND	GND	A29
B30	PETn 204	PERn 204	A30
B31	PETp 204	PERp 204	A31
B32	GND	GND	A32
B33	PETn 215	PERn 215	A33
B34	PETp 215	PERp 215	A34
B35	GND	GND	A35
B36	PETn 226	PERn 226	A36
B37	PETp 226	PERp 226	A37
B38	GND	GND	A38
B39	PETn 237	PERn 237	A39
B40	PETp 237	PERp 237	A40
B41	GND	GND	A41
B42	PRSNTB0#	PRSNTB1#	A42
Mechanical Key			
B43	GND	GND	A43
B44	PETn 248	PERn 248	A44
B45	PETp 248	PERp 248	A45
B46	GND	GND	A46
B47	PETn 259	PERn 259	A47
B48	PETp 259	PERp 259	A48
B49	GND	GND	A49

Secondary Connector (4C, x16, 140-pin OCP NIC 3.0 card)

B50	PETn 2640	PERn 2640	A50
B51	PETp 2640	PERp 2640	A51
B52	GND	GND	A52
B53	PETn 2744	PERn 2744	A53
B54	PETp 2744	PERp 2744	A54
B55	GND	GND	A55
B56	PETn 2842	PERn 2842	A56
B57	PETp 2842	PERp 2842	A57
B58	GND	GND	A58
B59	PETn 2943	PERn 2943	A59
B60	PETp 2943	PERp 2943	A60
B61	GND	GND	A61
B62	PETn 3044	PERn 3044	A62
B63	PETp 3044	PERp 3044	A63
B64	GND	GND	A64
B65	PETn 3145	PERn 3145	A65
B66	PETp 3145	PERp 3145	A66
B67	GND	GND	A67
B68	RFU 34 , N/C	UART_RX	A68
B69	RFU 42 , N/C	UART_TX	A69
B70	PRSNB3#	PWRBRK1#	A70

3.4 Signal Descriptions

The pins shown in this section are common for both the Primary and Secondary Connectors unless otherwise noted. Pins that exist only for the Primary Connector OCP Bay are explicitly called out in the pin location column with the prefix “OCP_xxx”. USB is only defined on the Primary Connector. UART is only defined on the secondary connector. All pin directions are from the perspective of the baseboard.

Note: The OCP NIC 3.0 card shall implement protection methods to prevent leakage or low impedance paths between the V_{AUX} and V_{MAIN} power domains in the event that a powered-down NIC is physically present in a powered-up baseboard. This specification provides example isolation implementations in the signal description text and appropriate figures. OCP NIC 3.0 implementers may choose to do a different implementation as long as the isolation requirements are met and the same result is achieved.

3.4.1 PCIe Interface Pins

This section provides the pin assignments for the PCIe interface signals. [The PCIe signals have unique names on the Primary and Secondary connector. The Primary Connector uses the REFCLK\[0:3\], TX/RX\[0:15\], PERST\[0:3\] indices. The Secondary Connector uses the REFCLK\[4:5\], TX/RX\[16:31\] and PERST\[4:5\] indices. Where applicable, the Primary/Secondary connector naming convention is shown as a pair.](#) The AC/DC specifications are defined in the PCIe CEM Specification, Rev 4.0. Example connection diagrams for are shown in [Section 3.6, Figure 90 and Figure 91.](#)

Table 2120: Pin Descriptions – PCIe

Signal Name (Primary / Secondary)	Pin #	Baseboard Direction	Signal Description
REFCLKn0/REFCLKn4	B14	Output	
REFCLKp0/REFCLKp4	B15		

REFCLKn1/ REFCLKn5 REFCLKp1/ REFCLKp5	A14 A15	Output	PCIe compliant differential reference clock #0, #1, #2 and #3. 100MHz reference clocks are used for the OCP NIC 3.0 card PCIe core logic.
REFCLKn2 REFCLKp2	OCP_B11 OCP_B12	Output	<p>REFCLK0 is always available to all OCP NIC 3.0 cards. The card should not assume REFCLK1, REFCLK2 or REFCLK3 are available until the bifurcation negotiation process is complete.</p> <p>For baseboards, the REFCLK0, REFCLK1, REFCLK2 and REFCLK3 signals shall be available at the Primary connector Connector for supported designs. Separate REFCLK0 and REFCLK1 instances are available for the Primary and Secondary connectors. REFCLK2 and REFCLK3 are only available on the Primary connector in the OCP Bay. REFCLK4 and REFCLK5 are available on the Secondary connector.</p> <ul style="list-style-type: none"> REFCLK0 is required for all designs. REFCLK1, REFCLK2 and REFCLK3 are required for designs that support 2 xn, and 4 xn bifurcation implementations. <p>For baseboards that implementations that use REFCLK[1:3], REFCLK2 and REFCLK3, the baseboard should disable the appropriate REFCLKs not used by the OCP NIC 3.0 card.</p> <p>The baseboard shall not advertise the corresponding bifurcation modes if REFCLK[1:3], REFCLK2 or REFCLK3 are not implemented.</p> <p>REFCLK4 and REFCLK5 are only available on the Secondary Connector and are not defined for use this specification release.</p> <p>For OCP NIC 3.0 cards, the required REFCLKs shall be connected per the endpoint datasheet. Unused REFCLKs on the OCP NIC 3.0 card shall be left as a no connect.</p> <p>Note: For cards that only support 1 x16, REFCLK0 is used. For cards that support 2 x8, REFCLK0 is used for the first eight PCIe lanes, and REFCLK1 is used for the second eight PCIe lanes. REFCLK2 and</p>
REFCLKn3 REFCLKp3	OCP_A11 OCP_A12	Output	

			<p>REFCLK3 are only used for cards that only support a four link PCIe bifurcation mode.</p> <p>Refer to Section 2.1 in the PCIe CEM Specification, Rev 4.0 for electrical details.</p>
PETn0 / PETn16 PETp0 / PETp16	B17 B18	Output	<p>Transmitter differential pairs [0:15] (Primary Connector), and differential pairs [16:31] (Secondary Connector). These pins are connected from the baseboard transmitter differential pairs to the receiver differential pairs on the OCP NIC 3.0 card.</p> <p>The PCIe transmit pins shall be AC coupled on the baseboard with capacitors. The AC coupling capacitor value shall use the C_{TX} parameter value specified in the PCIe Base Specification Rev 4.0 Section 8.3.9.</p> <p>For baseboards, the PET[0:15] signals are required at the Primary eConnector for a SFF slot. PET[0:15] and PET[16:31] are required for a LFF slot.</p> <p>For SFF OCP NIC 3.0 cards, the required PET[0:15] signals shall be connected to the endpoint silicon. For silicon that uses less than a x16 connection, the appropriate PET[0:15] signals shall be connected per the endpoint datasheet.</p> <p>For LFF implementations, PET[0:15] are assigned to the Primary Connector, and PET[16:31] are assigned to the Secondary Connector.</p> <p>Refer to Section 6.1 in the PCIe CEM Specification, Rev 4.0 for details.</p>
PETn1 / PETn17 PETp1 / PETp17	B20 B21	Output	
PETn2 / PETn18 PETp2 / PETp18	B23 B24	Output	
PETn3 / PETn19 PETp3 / PETp19	B26 B27	Output	
PETn4 / PETn20 PETp4 / PETp20	B30 B31	Output	
PETn5 / PETn21 PETp5 / PETp21	B33 B34	Output	
PETn6 / PETn22 PETp6 / PETp22	B36 B37	Output	
PETn7 / PETn23 PETp7 / PETp23	B39 B40	Output	
PETn8 / PETn24 PETp8 / PETp24	B44 B45	Output	
PETn9 / PETn25 PETp9 / PETp25	B47 B48	Output	
PETn10 / PETn26 PETp10 / PETp26	B50 B51	Output	
PETn11 / PETn27 PETp11 / PETp27	B53 B54	Output	
PETn12 / PETn28 PETp12 / PETp28	B56 B57	Output	
PETn13 / PETn29 PETp13 / PETp29	B59 B60	Output	
PETn14 / PETn30 PETp14 / PETp30	B62 B63	Output	
PETn15 / PETn31 PETp15 / PETp31	B65 B66	Output	
PERn0 / PERn16 PERp0 / PERp16	A17 A18	Input	<p>Receiver differential pairs [0:15] (Primary Connector), and differential pairs [16:31] (Secondary Connector). These pins are connected from the OCP NIC 3.0 card transmitter differential pairs to the receiver differential pairs on the baseboard.</p>
PERn1 / PERn17 PERp1 / PERp17	A20 A21	Input	
PERn2 / PERn18 PERp2 / PERp18	A23 A24	Input	

PERn3 / PERn19 PERp3 / PERp19	A26 A27	Input	<p>The PCIe receive pins shall be AC coupled on the OCP NIC 3.0 card with capacitors. The AC coupling capacitor value shall use the C_{TX} parameter value specified in the PCIe Base Specification Rev 4.0 Section 8.3.9.</p> <p>For baseboards, the PER[0:15] signals are required at the Primary eConnector for a SFF slot. PER[0:15] and PER[16:31] are required for a LFF slot.</p> <p>For SFF OCP NIC 3.0 cards, the required PER[0:15] signals shall be connected to the endpoint silicon. For silicon that uses less than a x16 connection, the appropriate PER[0:15] signals shall be connected per the endpoint datasheet.</p> <p>For LFF implementations, PER[0:15] are assigned to the Primary Connector, and PER[16:31] are assigned to the Secondary Connector.</p> <p>Refer to Section 6.1 in the PCIe CEM Specification, Rev 4.0 for details.</p>	
PERn4 / PERn20 PERp4 / PERp20	A30 A31	Input		
PERn5 / PERn21 PERp5 / PERp21	A33 A34	Input		
PERn6 / PERn22 PERp6 / PERp22	A36 A37	Input		
PERn7 / PERn23 PERp7 / PERp23	A39 A40	Input		
PERn8 / PERn24 PERp8 / PERp24	A44 A45	Input		
PERn9 / PERn25 PERp9 / PERp25	A47 A48	Input		
PERn10 / PERn26 PERp10 / PERp26	A50 A51	Input		
PERn11 / PERn27 PERp11 / PERp27	A53 A54	Input		
PERn12 / PERn28 PERp12 / PERp28	A56 A57	Input		
PERn13 / PERn29 PERp13 / PERp29	A59 A60	Input		
PERn14 / PERn30 PERp14 / PERp30	A62 A63	Input		
PERn15 / PERn31 PERp15 / PERp31	A65 A66	Input		
PERST0# / PERST4# PERST1# / PERST5# PERST2# PERST3#	B10 A11 OCP_A1 OCP_A2	Output		<p>PCIe Reset #[0:5], #1, #2, and #3. Active low.</p> <p>When PERSTn# is deasserted, the signal shall indicate the power state is already in Main Power Mode and is within tolerance and stable for the OCP NIC 3.0 card to bring up the PCIe link.</p> <p>PERST# shall be deasserted at least 1s after the NIC_PWR_GOOD assertion to Main Power Mode. This ensures the card power rails are within the operating limits. This value is longer than the minimum value specified in the PCIe CEM Specification. The PCIe REFCLKs shall also become stable within this period of time.</p> <p>PERST[0:5]# shall be asserted low on the baseboard until the platform is ready to deassert reset.</p> <p>For baseboards that support bifurcation, the PERST[0:13]# signals are required at the Primary and Secondary connectorsConnector,</p>

			<p>PERST[2:34:5]# are required only supported for at the Primary Secondary Connector.</p> <p>For OCP NIC 3.0 cards, the required PERST[0:35]# signals shall be connected to the endpoint silicon. Unused PERST[0:35]# signals shall be left as a no connect.</p> <p>Note: For cards that only support 1 x16, PERST0# is used. For cards that support 2 x8, PERST0# is used for the first eight PCIe lanes, and PERST1# is used for the second eight PCIe lanes. PERST2# and PERST3# are only used for cards that support a four link PCIe bifurcation mode.</p> <p>PERST0# is always available to all OCP NIC 3.0 cards. The card should not assume PERST[1:5]#, PERST2# or PERST3# is are available until the bifurcation negotiation process is complete.</p> <p>Refer to Section 2.2 in the PCIe CEM Specification, Rev 4.0 for details.</p>
WAKE#	OCP_A3	Input, OD	<p>WAKE#. Open drain. Active low.</p> <p>This signal shall be driven by the OCP NIC 3.0 card to notify the baseboard to restore PCIe link. For OCP NIC 3.0 cards that support multiple WAKE# signals, their respective WAKE# pins may be tied together as the signal is open-drain to form a wired-OR. For multi-homed host configurations, the WAKE# signal assertion shall wake all nodes.</p> <p>For baseboards, this signal shall be pulled up to +3.3V_EDGE on the baseboard with a 10_kOhm resistor. This signals shall be connected to the system WAKE# signal.</p> <p>For OCP NIC 3.0 cards, this signal shall be connected between the endpoint silicon WAKE# pin(s) and the card edge through an isolation buffer. The WAKE# signal shall not assert until the PCIe card is in the D3 state according to the PCIe CEM specification to prevent false WAKE# events. For OCP NIC 3.0, the WAKE# pin shall be buffered or otherwise isolated from the host until the aux voltage source is present. Examples of this are shown in Section 3.5.5 by gating via an on-board "AUX_PWR_GOOD" signal to indicate all the NIC</p>

Commented [NT2]: What do we really want to do with multi-homed systems? Does WAKE# apply? Seems like a magic packet directed towards the BMC would work

Discuss in next working group.

			<p>AUX power rails are stable. The PCIe CEM specification also shows an example in the WAKE# signal section.</p> <p>This pin shall be left as a no connect if WAKE# is not supported by the silicon.</p> <p>Refer to Section 2.3 in the PCIe CEM Specification, Rev 4.0 for details.</p>
PWRBRK0# / PWRBRK1#	A70	Output, OD	<p>Power break. Active low, open drain.</p> <p>This signal shall be pulled up to +3.3V_EDGE on the OCP NIC 3.0 card with a minimum of 95_kOhm. The pull up on the baseboard shall be a stiffer resistance in-order to meet the timing specs as shown in the PCIe CEM Specification.</p> <p>When this signal is driven low by the baseboard, the Emergency Power Reduction State is requested. The OCP NIC 3.0 card shall move to a lower power consumption state.</p> <p>For baseboards, the PWRBRK0# pin shall be implemented and available on the Primary Connector for SFF slots. In addition, the PWRBRK1# pin shall be implemented on the Secondary connector for LFF slots.</p> <p>For OCP NIC 3.0 cards, the PWRBRK[0:1]# pin usage is optional. If used, the PWRBRK# should be connected to the network silicon to enable reduced power state. If not used, the PWRBRK[0:1]# signals shall be left as a no connect.</p> <p>Note: The PWRBRK[0:1]# pins is-are only available for OCP NIC 3.0 cards that implement a SFF 4C+ edge connector or a LFF. For SFF cards that implement at 2C+ edge connection, the PWRBRK[0:1]# functionality is not available.</p>

3.4.2 PCIe Present and Bifurcation Control Pins

This section provides the pin assignments for the PCIe present and bifurcation control signals. The AC/DC specifications are defined in Section [3.113-12](#). Example connection diagrams are shown in [Figure 76](#)[Figure 74](#) and [Figure 77](#)[Figure 75](#).

The PRSNTA#/PRSNTB[0:3]# state shall be used to determine if a card has been physically plugged in. [The BIF\[0:2\]# pins shall be asserted by the baseboard along with the rising edge of AUX_PWR_EN.](#) [The BIF\[0:2\]# pins shall be latched by the OCP NIC 3.0 card before when AUX_PWR_EN=1 and](#)

~~NIC_PWR_GOOD=1 assertion~~ to ensure the correct values are detected by the ~~system~~ OCP NIC 3.0 card. Changing the pin states after this timing window is not allowed. Refer to the AC timing diagram in Section 3.113-12 for details.

~~PRSNB[0:3]# pins are available to each connector and are independent of each other. For the SFF, the baseboard shall only read the Primary Connector PRSNB[0:3]# to determine the card type. For the LFF, the baseboard shall read both the Primary and Secondary connector PRSNB[0:3]# pins to determine the card type. The card type matrix is discussed in Section 3.5.~~

Table 224: Pin Descriptions – PCIe Present and Bifurcation Control Pins

Signal Name	Pin #	Baseboard Direction	Signal Description
PRSNB#	A10	Output	Present A is used for OCP NIC 3.0 card presence and PCIe capabilities detection. For baseboards, this pin shall be directly connected to GND. For OCP NIC 3.0 cards, this pin shall be directly connected to the PRSNB[3:0]# pins.
PRSNB0# PRSNB1# PRSNB2# PRSNB3#	B42 A42 A12 B70	Input	Present B [0:3]# are used for OCP NIC 3.0 card presence and PCIe capabilities detection. For baseboards, these pins shall be connected to the I/O hub and pulled up to +3.3V_EDGE using 1_kOhm resistors. For OCP NIC 3.0 cards, these pins shall be strapped to PRSNB# per the encoding definitions described in Section 3.5. Note: PRSNB3# is located at the bottom of the 4C connector and is only applicable for OCP NIC 3.0 cards with a PCIe width of x16 (or greater). OCP NIC 3.0 cards that implement a 2C card edge do not use the PRSNB3# pin for capabilities or present detection.
BIF0# BIF1# BIF2#	B7 B8 B9	Output	Bifurcation [0:2]# pins allow the baseboard to force configure the OCP NIC 3.0 card bifurcation. For baseboards, the BIF[0:2]# these pins shall be outputs driven from the baseboard I/O hub on the rising edge of AUX_PWR_EN. and This allows the system-baseboard to force configure the OCP NIC 3.0 card bifurcation. The baseboard may optionally pull the BIF[0:2]# signals to AUX_PWR_EN or to ground

Commented [NT3]: See timing diagram. As HPE pointed out, the BIF[2:0]# pins are driven low (or pulled low) before AUX_PWR_EN.

The original text in 0v83 and earlier state that the BIF[0:2] pins are latched prior to the (AUX_)PWR_EN signal assertion. This does not work.

New suggestion is to latch BIF[0:2]# when AUX_PWR_EN=1 && NIC_PWR_GOOD=1 (e.g. the BIF[2:0]# signals are latched upon the transition from "AUX Power Mode Transition" and "Aux Power Mode" (see Section 3.12 for the startup diagram).

		<p>per the definitions are described in Section 3.5 if no dynamic bifurcation configuration is required.</p> <p>The BIF[0:2]# pins shall be low until AUX_PWR_EN is asserted to prevent leakage paths into an unpowered card.</p> <p>For baseboards that allow dynamic bifurcation, the BIF[0:2] pins are driven low prior to AUX_PWR_EN. The state of the BIF[0:2] pins are driven with the rising edge of AUX_PWR_EN when bifurcation is requested. Refer to Figure 76 Figure 74 for an example configuration.</p> <p>For baseboards with static bifurcation, the BIF pins that are intended to be a logical '1' shall be connected to a pull up to AUX_PWR_EN. BIF pins that are a logical '0' may be directly tied to ground. Refer to Figure 77 Figure 75 for an example configuration.</p> <p>For OCP NIC 3.0 cards, these signals shall connect to the endpoint bifurcation pins if it is supported. The BIF[0:2]# signals shall be left as no connects if endpoint bifurcation is not supported. The value of the BIF[2:0]# pins are latched by the OCP NIC 3.0 card upon entering the AUX power mode state (when AUX_PWR_EN=1 and NIC_PWR_GOOD=1).</p> <p>Note: the required combinatorial logic output for endpoint bifurcation is dependent on the specific silicon and is not defined in this specification.</p>
--	--	--

Figure 7674: PCIe Present and Bifurcation Control Pins (Baseboard Controlled BIF[0:2]#)

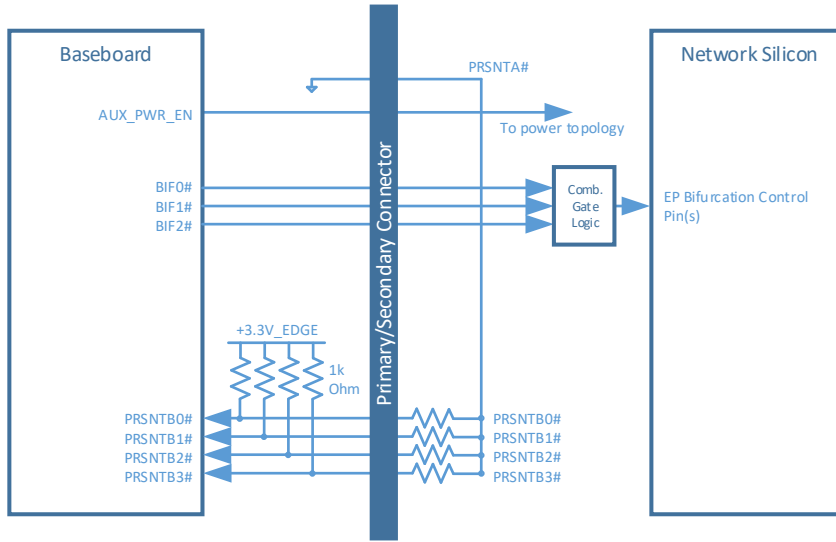
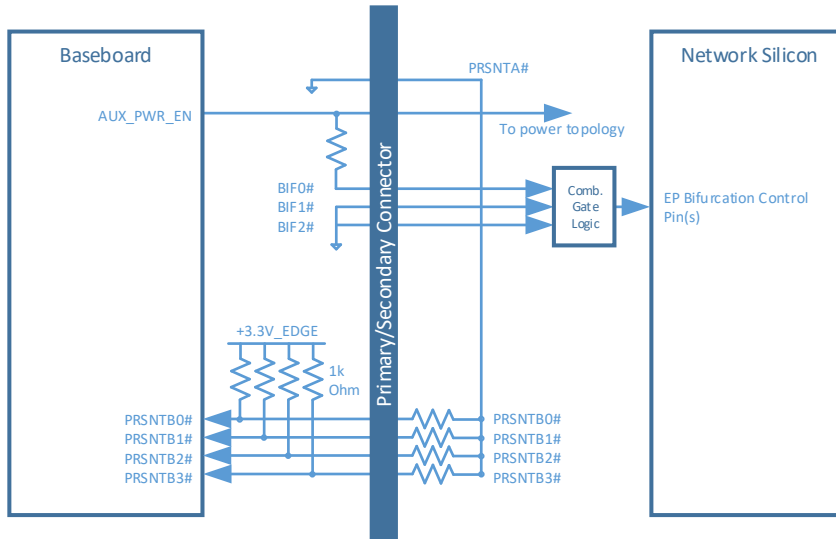

Figure 7775: PCIe Present and Bifurcation Control Pins (Static BIF[0:2]#)



3.4.3 SMBus Interface Pins

This section provides the pin assignments for the SMBus interface signals. The AC/DC specifications are defined in the SMBus 2.0 and I²C bus specifications. An example connection diagram is shown in [Figure 78](#)[Figure 76](#).

Table [2322](#): Pin Descriptions – SMBus

Signal Name	Pin #	Baseboard Direction	Signal Description
SMCLK	A7	Output, OD	<p>SMBus clock. Open drain, pulled up to +3.3V_EDGE on the baseboard.</p> <p>For baseboards, the SMCLK from the platform SMBus master shall be connected to the connector.</p> <p>For OCP NIC 3.0 cards, the SMCLK from the endpoint silicon shall be connected to the card edge gold fingers.</p>
SMDAT	A8	Input / Output, OD	<p>SMBus Data. Open drain, pulled up to +3.3V_EDGE on the baseboard.</p> <p>For baseboards, the SMDAT from the platform SMBus master shall be connected to the connector.</p> <p>For OCP NIC 3.0 cards, the SMDAT from the endpoint silicon shall be connected to the card edge gold fingers.</p>
SMRST#	A9	Output, OD	<p>SMBus reset. Open drain.</p> <p>For baseboards, this pin shall be pulled up to +3.3V_EDGE. The SMRST pin may be used to reset optional downstream SMBus devices (such as temperature sensors). The SMRST# implementation shall be mandatory for baseboard implementations.</p> <p>For OCP NIC 3.0 cards, SMRST# is optional and is dependent on the OCP NIC 3.0 card implementation. If used, the SMRST# is on the +3.3V_EDGE power domain. Isolation logic may be required if the target device(s) exist on a different power domain to prevent a leakage path. The SMRST# signal shall be left as a no connect if it is not used on the OCP NIC 3.0 card.</p>

Figure 7876: Example SMBus Connections

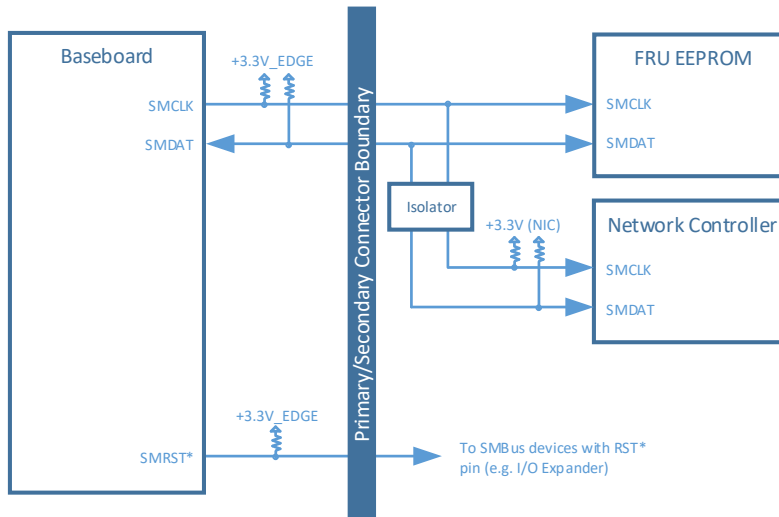

3.4.4 NC-SI Over RBT Interface Pins

This section provides the pin assignments for the NC-SI over RBT interface signals on the Primary Connector OCP bay. The AC/DC specifications for NC-SI over RBT are defined in the DMTF DSP0222 NC-SI specification. An example connection diagram is shown in Figure 79 and Figure 80.

Note: The RBT pins must provide the ability to be isolated on the baseboard side when AUX_PWR_EN=0 or when (AUX_PWR_EN=1 and NIC_PWR_GOOD=0). The RBT pins shall remain isolated until the RBT pins shall not be isolated when the power state machine has transitioned to AUX power mode or the transition to Main Power Mode along with a valid indication of NIC_PWR_GOOD. This prevents a leakage path through unpowered silicon. The RBT REF_CLK must also be disabled until AUX_PWR_EN=1 and NIC_PWR_GOOD=1. Example buffering implementations are shown in Figure 79 and Figure 80. The isolator shall be controlled on the baseboard with a signal called RBT_ISOLATE#.

Table 2423: Pin Descriptions – NC-SI Over RBT

Signal Name	Pin #	Baseboard Direction	Signal Description
RBT_REF_CLK	OCP_A14	Output	Reference clock input. Synchronous clock reference for receive, transmit and control interface. The clock shall have a typical frequency of 50MHz. For baseboards, this pin shall be connected between the baseboard NC-SI over RBT PHY and the Primary Connector OCP bay. This signal requires a 100_kOhm

			<p>pull down resistor on the baseboard. If the baseboard does not support NC-SI over RBT, then this signal shall be terminated to ground through a 100_kOhm pull down resistor. The RBT_REF_CLK shall not be driven until the card has transitioned into AUX Power Mode.</p> <p>For OCP NIC 3.0 cards, this pin shall be connected between the card gold finger to and the endpoint silicon. This pin shall be left as a no connect if NC-SI over RBT is not supported.</p>
RBT_CRS_DV	OCP_B14	Input	<p>Carrier sense/receive data valid. This signal is used to indicate to the baseboard that the carrier sense/receive data is valid.</p> <p>For baseboards, this pin shall be connected between the baseboard NC-SI over RBT PHY and the connector. This signal requires a 100_kOhm pull down resistor on the baseboard. If the baseboard does not support NC-SI over RBT, then this signal shall be terminated to ground through a 100_kOhm pull down resistor.</p> <p>For OCP NIC 3.0 cards, this pin shall be connected between the card gold finger to and the endpoint silicon. This pin shall be left as a no connect if NC-SI over RBT is not supported.</p>
RBT_RXD0 RBT_RXD1	OCP_B9 OCP_B8	Input	<p>Receive data. Data signals from the network controller to the BMC.</p> <p>For baseboards, this pin shall be connected between the baseboard NC-SI over RBT PHY and the connector. This signal requires a 100_kOhm pull down resistor to GND on the baseboard. If the baseboard does not support NC-SI over RBT, then this signal shall be terminated to GND through a 100_kOhm pull down.</p> <p>For OCP NIC 3.0 cards, this pin shall be connected between the card gold fingers and the RBT_RXD[0:1] pins on endpoint silicon. This pin shall be left as a no connect if NC-SI over RBT is not supported.</p>
RBT_TX_EN	OCP_A7	Output	<p>Transmit enable.</p> <p>For baseboards, this pin shall be connected between the baseboard NC-SI over RBT PHY and the connector. This signal requires a 100_kOhm pull down resistor to ground on the baseboard. If the</p>

			<p>baseboard does not support NC-SI over RBT, then this signal shall be terminated to ground through a 100_kOhm pull down.</p> <p>For OCP NIC 3.0 cards, this pin shall be connected between the card gold finger to and the endpoint silicon. This pin shall be left as a no connect if NC-SI over RBT is not supported.</p>
RBT_TXD0 RBT_TXD1	OCP_A9 OCP_A8	Output	<p>Transmit data. Data signals from the BMC to the network controller.</p> <p>For baseboards, this pin shall be connected between the baseboard NC-SI over RBT PHY and the connector. This signal requires a 100_kOhm pull down resistor to GND on the baseboard. If the baseboard does not support NC-SI over RBT, then this signal shall be terminated to GND through a 100_kOhm pull down.</p> <p>For OCP NIC 3.0 cards, this pin shall be connected between the card gold fingers to and the RBT_TXD[0:1] pins on the endpoint silicon. This pin shall be left as a no connect if NC-SI over RBT is not supported.</p>
RBT_ARB_OUT	OCP_A5	Output	<p>NC-SI hardware arbitration output.</p> <p>If the baseboard does not support NC-SI over RBT or implements only one OCP NIC 3.0 interface, this signal shall be directly connected to the RBT_ARB_IN pin to complete the hardware arbitration ring on the OCP NIC 3.0 card. If the baseboard supports multiple OCP NIC 3.0 cards connected to the same RBT interface, it shall implement logic that connects the RBT_ARB_OUT pin of the first populated OCP NIC 3.0 card to its RBT_ARB_IN pin if it is the only card present or to the RBT_ARB_IN pin of the next populated card and so on sequentially for all cards on the specified RBT bus to ensure the arbitration ring is complete. A two OCP NIC 3.0 card example using an analog mux is shown in Figure 80Figure 78.</p> <p>For OCP NIC 3.0 cards that support hardware arbitration, this pin shall be connected between the card gold finger to and the RBT_ARB_IN pin on the endpoint silicon. If the card implements two controllers, both must be connected internally to complete the ring, see Figure 80Figure 78. If hardware arbitration is not supported, then this pin</p>

			shall be directly connected to the card edge RBT_ARB_IN pin. This allows the hardware arbitration signals to pass through in a multi-Primary Connector baseboard.						
RBT_ARB_IN	OCP_A4	Input	<p>NC-SI hardware arbitration input.</p> <p>If the baseboard does not support NC-SI over RBT or implements only one OCP NIC 3.0 interface, this signal shall be directly connected to the RBT_ARB_OUT pin to complete the hardware arbitration ring on the OCP NIC 3.0 card. If the baseboard supports multiple OCP NIC 3.0 cards connected to the same RBT interface, it shall implement logic that connects the RBT_ARB_IN pin of the first populated OCP NIC 3.0 card to its RBT_ARB_OUT pin if it is the only card present or to the RBT_ARB_OUT pin of the next populated card and so on sequentially for all cards on the specified RBT bus to ensure the arbitration ring is complete. A two OCP NIC 3.0 card example using an analog mux is shown in Figure 80Figure 78.</p> <p>For OCP NIC 3.0 cards that support hardware arbitration, this pin shall be connected between the card gold finger to and the RBT_ARB_OUT pin on the endpoint silicon. If the card implements two controllers, both must be connected internally to complete the ring, see Figure 80Figure 78. If hardware arbitration is not supported, then this pin shall be directly connected to the card edge RBT_ARB_OUT pin. This allows the hardware arbitration signals to pass through in a multi-Primary Connector baseboard.</p>						
SLOT_ID0 SLOT_ID1	OCP_B7 OCP_A6	Output	<p>NC-SI / FRU EEPROM Address 0/1.</p> <p>The SLOT_ID[1:0] pins shall be used to set the RBT Package ID. This pin is also used in setting the FRU EEPROM address.</p> <p>For baseboards, the SLOT_ID[1:0] pins shall be physically tied to GND or to +3.3V_EDGE. The SLOT[1:0] values are based on the following mapping:</p> <table border="1" data-bbox="592 1585 1071 1669"> <thead> <tr> <th>Physical Slot (Decimal)</th> <th>SLOT_ID1 OCP_A6</th> <th>SLOT_ID0 OCP_B7</th> </tr> </thead> <tbody> <tr> <td>0</td> <td>0</td> <td>0</td> </tr> </tbody> </table>	Physical Slot (Decimal)	SLOT_ID1 OCP_A6	SLOT_ID0 OCP_B7	0	0	0
Physical Slot (Decimal)	SLOT_ID1 OCP_A6	SLOT_ID0 OCP_B7							
0	0	0							

			1	0	1
			2	1	0
			3	1	1

For OCP NIC 3.0 cards, SLOT_ID0 shall be connected to the endpoint device GPIO associated with Package ID[0]. SLOT_ID1 shall be associated with Package ID[1]. Refer to Section 4.8.1 and the device datasheet for details.

For OCP NIC 3.0 cards with multiple endpoint devices, Package ID[2] shall be used to identify a second physical RBT capable controller on the same physical card.

For Package ID addressing, the SLOT_ID[1:0] pins shall be buffered on NIC side with a FET switch (or a similar implementation) to prevent a leakage path when the OCP NIC 3.0 card is in ID mode. The SLOT_ID[1:0] buffers shall isolate the signals to the network silicon until an "Aux Power Good" is generated locally from the NIC. This indication shall be generated from an on-board voltage monitor or similar logic. OCP NIC 3.0 designers may omit isolation logic for the Package ID addressing if the target silicon properly isolates the signals when it is unpowered.

For FRU EEPROM addressing, the SLOT_ID0 pin shall be directly connected to the EEPROM A1 address pin; SLOT_ID1 shall be connected to the EEPROM A2 address pin. No isolation shall be used for the FRU EEPROM connections.

For endpoint devices without NC-SI over RBT support, these pins shall only be connected to the FRU EEPROM as previously described.

Figure 7977: NC-SI Over-over RBT Connection Example – Single Primary Connector

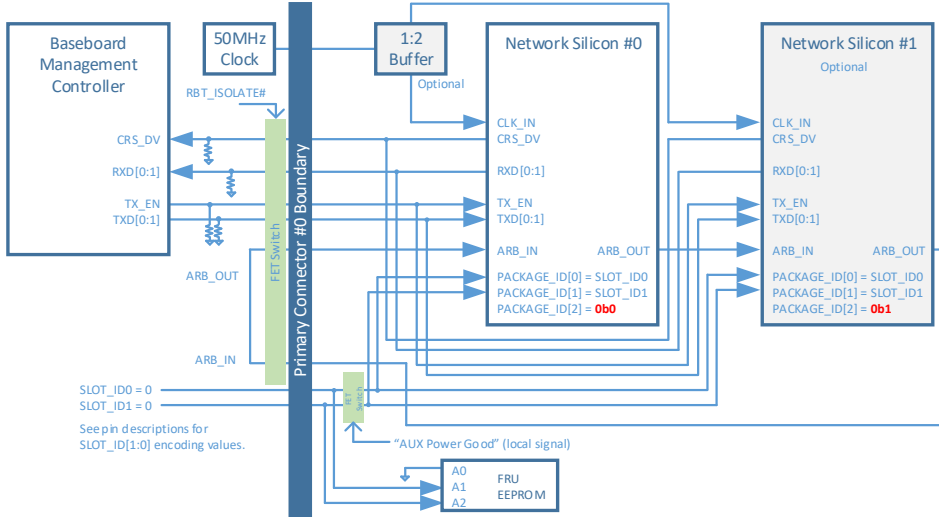
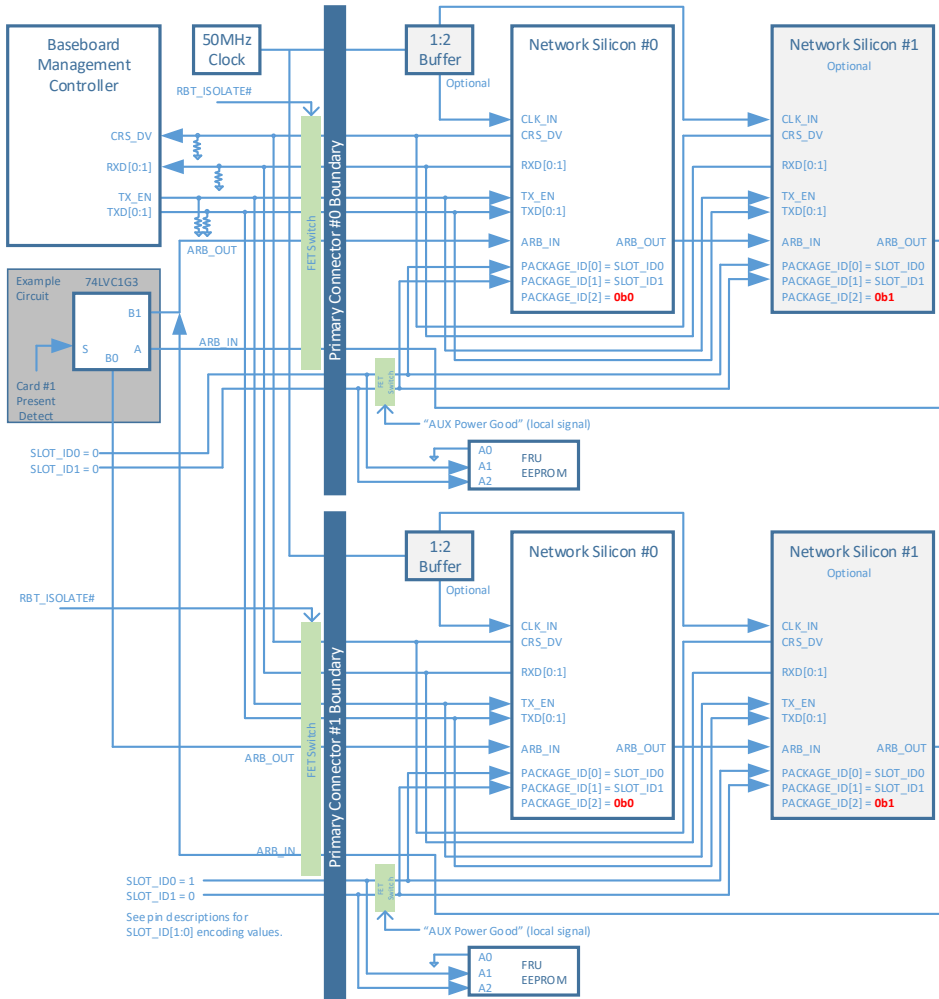

Figure 8078: NC-SI Over-over RBT Connection Example – Dual Primary Connectors



Note 1: For baseboard designs with a single Primary Connector, connect ARB_IN to ARB_OUT to complete the NC-SI hardware arbitration ring. For designs with multiple Primary Connectors, connect ARB_IN and ARB_OUT to an analog mux to complete the NC-SI arbitration ring based on the number of cards installed in the system. An example dual Primary Connector implementation is shown in [Figure 8078](#).

Note 2: For baseboard implementations having two or more RBT busses, the baseboard hardware arbitration rings shall remain within their respective bus and shall not cross RBT bus domains.

Note 3: The logical implementation of the hardware arbitration ring shall maintain the arbitration ring integrity when there exists one or more cards that are plugged in, but are powered off (e.g. in ID Mode).

Note 4: For OCP NIC 3.0 cards with two discrete endpoint silicon, the Package ID[2] bit shall be statically set based on the silicon instance. For example, the figure above shows Network Silicon #0 and Network Silicon #1. Network Silicon #0 has Package ID[2] = 0b0, Network Silicon #1 has Package ID[2] = 0b1.

Note 5: Designs that implement a clock fan out buffer will affect the RBT timing budget. Careful analysis of the timing budget is required. Refer to Section 5.1 for RBT signal integrity and timing budget considerations.

3.4.5 Scan Chain Pins

This section provides the pin assignments for the Scan Chain interface signals on the Primary Connector OCP Bay. The scan chain is a point-to-point bus on a per OCP slot basis. The scan chain consists of two unidirectional busses, a common clock and a common load signal. The DATA_OUT signal serially shifts control signals from the baseboard to the OCP NIC 3.0 card. The DATA_IN signal serially shifts bits from the OCP NIC 3.0 card to the baseboard. The DATA_OUT and DATA_IN chains are independent of each other. The scan chain CLK is driven from the baseboard. The LD pin, when asserted by the baseboard, allows loading of the data on to the shift registers. An example timing diagram is shown in [Figure 81Figure-79](#). An example connection diagram is shown in [Figure 82Figure-80](#).

Note: The DATA_OUT chain is provisioned, but is not used on OCP NIC 3.0 cards for this revision of the specification.

Table 2524: Pin Descriptions – Scan Chain

Signal Name	Pin #	Baseboard Direction	Signal Description
CLK	OCB_B6	Output	<p>Scan clock. The CLK is an output pin from the baseboard to the OCP NIC 3.0 card. The CLK may run up to 12.5MHz.</p> <p>For baseboard implementations, the CLK pin shall be connected to the Primary Connector. The CLK pin shall be tied directly to GND if the scan chain is not used.</p> <p>For NIC implementations, the CLK pin shall be connected to Shift Registers 0 & 1, and optionally connected to Shift Registers 2 & 3 (if implemented) as defined in the text and Figure 82Figure-80, below. The CLK pin shall be pulled up to +3.3V_EDGE through a 1_kOhm resistor.</p>

DATA_OUT	OCP_B5	Output	<p>Scan data output from the baseboard to the OCP NIC 3.0 card. This bit stream is used to shift configuration data out to the NIC.</p> <p>For baseboard implementations, the DATA_OUT pin shall be connected to the Primary Connector. The DATA_OUT pin shall be pulled down to GND through a 1_kOhm resistor if the scan chain is not used.</p> <p>For NIC implementations, the DATA_OUT pin shall be pulled down to GND on the OCP NIC 3.0 card through a 10_kOhm resistor.</p>
DATA_IN	OCP_B4	Input	<p>Scan data input to the baseboard. This bit stream is used to shift out NIC status bits to the baseboard.</p> <p>For baseboard implementations, the DATA_IN pin shall be pulled up to +3.3V_EDGE through a 10_kOhm resistor to prevent the input signal from floating if a card is not installed. This pin may be left as a no connect if the scan chain is not used.</p> <p>For NIC implementations, the DATA_IN scan chain is required. The DATA_IN pin shall be connected to Shift Register 0, as defined in the text and Figure 82Figure 80.</p>
LD#	OCP_B3	Output	<p>Scan shift register load. Used to latch configuration data on the OCP NIC 3.0 card.</p> <p>For baseboard implementations, the LD# pin shall be pulled up to +3.3V_EDGE through a 1_kOhm resistor if the scan chain is not used to prevent the OCP NIC 3.0 card from erroneous data latching.</p> <p>For NIC implementations, the LD# pin implementation is required. The LD# pin shall be connected to Shift Registers 0 & 1, and optionally connected to Shift Registers 2 & 3 (if implemented) as defined in the text and Figure 82Figure 80. The LD# pin shall be pulled up to +3.3V_EDGE through a 10_kOhm resistor.</p>

Figure [8179](#): Example Scan Chain Timing Diagram

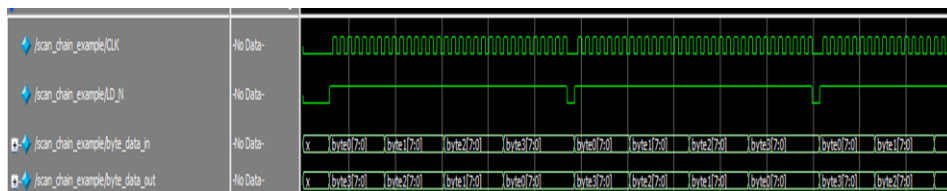

The scan chain provides sideband status indication between the OCP NIC 3.0 card and the baseboard. The scan chain bit definition is defined in the two tables below. The scan chain data stream is 32-bits in length for both the DATA_OUT and the DATA_IN streams. The scan chain implementation is optional on the host, but its implementation is mandatory per [Table 26](#) and [Table 27](#) on all OCP NIC 3.0 cards. The scan chain components operates on the +3.3V_EDGE power domain.

The DATA_OUT bus is an output from the host. The DATA_OUT bus provides initial configuration options to the OCP NIC 3.0 card. At the time of this writing, the DATA_OUT bus is not used. All baseboard systems that implement the Scan Chain shall connect DATA_OUT between the platform and the Primary Connector for subsequent revisions of this specification. The DATA_OUT data stream shall shift out all 0's prior to AUX_PWR_EN assertion to prevent leakage paths into unpowered silicon.

Table 26: Pin Descriptions – Scan Chain DATA_OUT Bit Definition

Byte.bit	DATA_OUT Field Name	Default Value	Description
0.[0..7]	RSVD	0h00	Reserved. Byte 0 value is 0h00.
1.[0..7]	RSVD	0h00	Reserved. Byte 1 value is 0h00.
2.[0..7]	RSVD	0h00	Reserved. Byte 2 value is 0h00.
3.[0..7]	RSVD	0h00	Reserved. Byte 3 value is 0h00.

The DATA_IN bus is an input to the host and provides NIC status indication. The default implementation is completed with two 8-bit 74LV165 parallel in to serial out shift registers in a cascaded implementation. Up to four shift registers may be implemented to provide additional NIC status indication to the host platform. [Alternatively, an OCP NIC 3.0 card vendor may choose to implement this chain using an active device \(such as a microcontroller or CPLD\). For active device implementations, there is an associated device start-up time. Refer to Section 3.11 for details on the +3.3V_EDGE stable to the first data valid read in ID Mode.](#)

DATA_IN shift register 0 shall be mandatory for scan chain implementations for the card present, WAKE_N and thermal threshold features. DATA_IN shift registers 1, 2 & 3 are optional depending on the line side I/O and LED fields being reported to the host. Dual port LED applications require shift register 1. Quad port LED applications require shift registers 1 & 2. Octal port applications require shift registers 1, 2 & 3.

The host should read the DATA_IN bus multiple times to qualify the incoming data stream. The number of data qualification reads is dependent on the baseboard implementation.

On the OCP NIC 3.0 card, a 1_kOhm pull up resistor shall be connected to the SER input of the last DATA_IN shift register. Doing so ensures the default bit value of 0b1 for implementations using less than four shift registers.

Table 2726: Pin Descriptions – Scan Chain DATA_IN Bit Definition

Byte.bit	DATA_IN Field Name	Default Value	Description
0.0	PRSNTB[0]#	0bX	PRSNTB[3:0]# bits shall reflect the same state as the signals on the Primary Connector. Connect these scan chain signals directly to the OCP NIC 3.0 card edge PRSNTB[3:0]# pins. The OCP NIC 3.0 implementer may alternatively choose to locally populate pull up and pull down resistors to these scan chain inputs as long as the PRSNTB[3:0]# values are the same on the scan chain and card edge.
0.1	PRSNTB[1]#	0bX	
0.2	PRSNTB[2]#	0bX	
0.3	PRSNTB[3]#	0bX	
0.4	WAKE_N	0bX	PCIe WAKE_N signal shall reflect the same state as the signal on the Primary Connector.
0.5	TEMP_WARN_N	0b1	Temperature monitoring pin from the on-card thermal solution. This pin shall be asserted low when the network silicon or transceiver module temperature sensor _s exceed _s the temperature warning threshold.
0.6	TEMP_CRIT_N	0b1	Temperature monitoring pin from the on-card thermal solution. This pin shall be asserted low when the network silicon or transceiver module temperature sensor _s exceed _s the temperature critical threshold.
0.7	FAN_ON_AUX	0b0	<p>When high, FAN_ON_AUX shall request the system fan to be enabled for extra cooling in the S5 state.</p> <p>The FAN_ON_AUX bit shall be asserted when the network silicon or transceiver module cooling requested threshold has been exceeded. The temperature at which this assertion occurs is device dependent.</p> <p>The FAN_ON_AUX bit shall deassert when the network silicon or transceiver module temperature is at least 5°C below the assertion threshold.</p> <p>0b0 – The system fan is not requested/off in S5. 0b1 – The system fan is requested/on in S5.</p>

1.0	LINK_SPDA_P0#	0b1	<p>Port 0 link and speed A indication (max speed). Active low.</p> <p>0b0 – Link LED is illuminated on the host platform. 0b1 – Link LED is not illuminated on the host platform.</p> <p>Steady = link is detected on the port and is at the maximum speed. Off = the physical link is down, the link is not operating at the maximum speed or the port is disabled.</p> <p>Note: The link and speed A LED may also be blinked for use as port identification.</p>
1.1	LINK_SPDB_P0#	0b1	<p>Port 0 link and speed B indication (not max speed). Active low.</p> <p>0b0 – Link LED is illuminated on the host platform. 0b1 – Link LED is not illuminated on the host platform.</p> <p>Steady = link is detected on the port and is not at the maximum speed. Off = the physical link is down, the link is operating at the maximum speed, or the port is disabled.</p> <p>Note: The link and speed B LED may also be blinked for use as port identification.</p>
1.2	ACT_P0#	0b1	<p>Port 0 activity indication. Active low.</p> <p>0b0 – ACT LED is illuminated on the host platform. 0b1 – ACT LED is not illuminated on the host platform.</p> <p>Steady = no activity is detected on the port. Blinking = activity is detected on the port. The blink rate should blink low for 50-500_ms during activity periods with a 50% duty cycle. Off = the physical link is down or disabled.</p>
1.3	LINK_SPDA_P1#	0b1	<p>Port 1 link and speed A indication (max speed). Active low.</p>
1.4	LINK_SPDB_P1#	0b1	<p>Port 1 link and speed B indication (not max speed). Active low.</p>
1.5	ACT_P1#	0b1	<p>Port 1 activity indication. Active low.</p>

1.6	LINK_SPDA_P2#	0b1	Port 2 link and speed A indication (max speed). Active low.
1.7	LINK_SPDB_P2#	0b1	Port 2 link and speed B indication (not max speed). Active low.
2.0	ACT_P2#	0b1	Port 2 activity indication. Active low.
2.1	LINK_SPDA_P3#	0b1	Port 3 link and speed A indication (max speed). Active low.
2.2	LINK_SPDB_P3#	0b1	Port 3 link and speed B indication (not max speed). Active low.
2.3	ACT_P3#	0b1	Port 3 activity indication. Active low.
2.4	LINK_SPDA_P4#	0b1	Port 4 link and speed A indication (max speed). Active low.
2.5	LINK_SPDB_P4#	0b1	Port 4 link and speed B indication (not max speed). Active low.
2.6	ACT_P4#	0b1	Port 4 activity indication. Active low.
2.7	LINK_SPDA_P5#	0b1	Port 5 link and speed A indication (max speed). Active low.
3.0	LINK_SPDB_P5#	0b1	Port 5 link and speed B indication (not max speed). Active low.
3.1	ACT_P5#	0b1	Port 5 activity indication. Active low.
3.2	LINK_SPDA_P6#	0b1	Port 6 link and speed A indication (max speed). Active low.
3.3	LINK_SPDB_P6#	0b1	Port 6 link and speed B indication (not max speed). Active low.
3.4	ACT_P6#	0b1	Port 6 activity indication. Active low.
3.5	LINK_SPDA_P7#	0b1	Port 7 link and speed A indication (max speed). Active low.
3.6	LINK_SPDB_P7#	0b1	Port 7 link and speed B indication (not max speed). Active low.
3.7	ACT_P7#	0b1	Port 7 activity indication. Active low.

Figure 8280: Scan Chain Connection Example

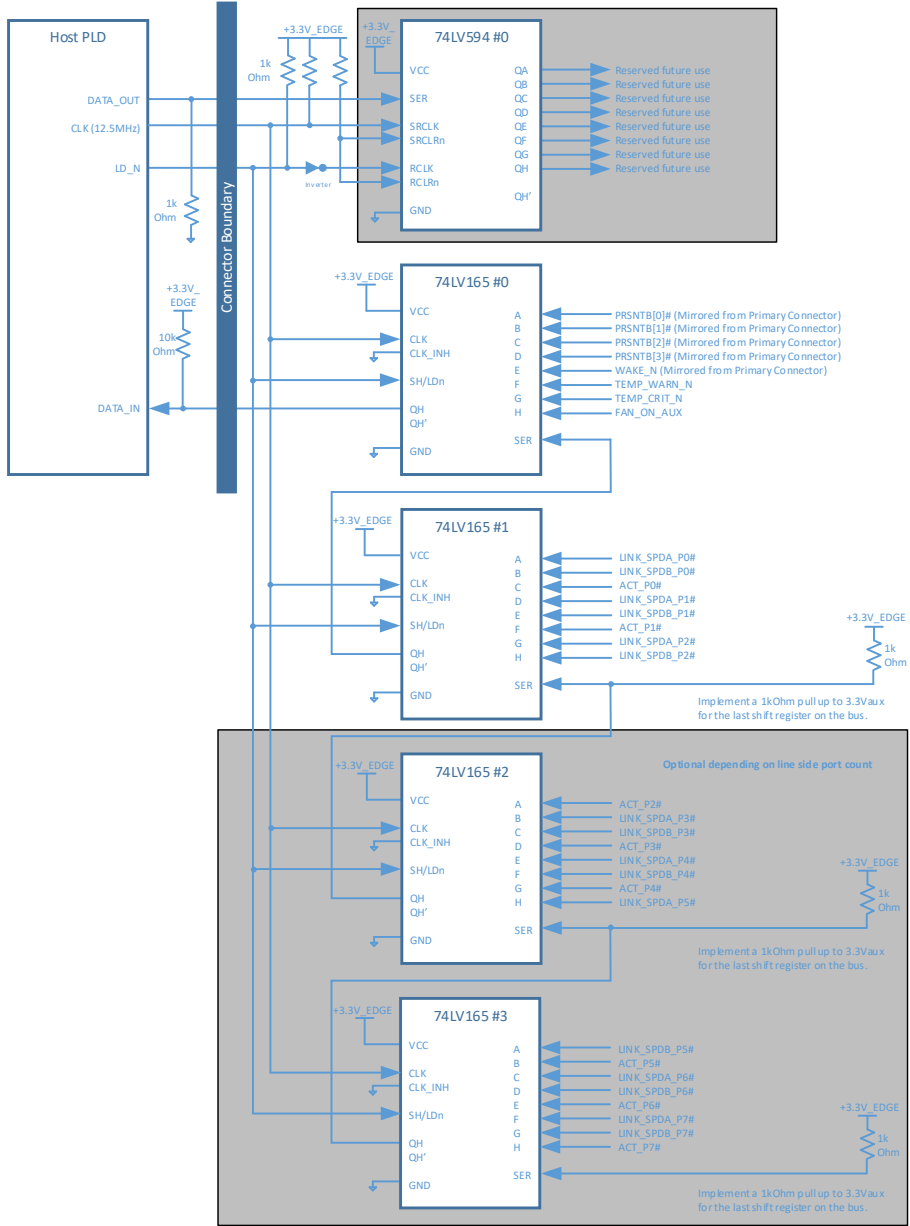

3.4.6 Power Supply Pins

This section provides the pin assignments for the power supply interface signals. The AC/DC specifications are defined in the PCIe CEM Specification, Rev 4.0 and amended in Section [3.93-10](#). An example connection diagram is shown in [Figure 83](#)~~Figure 81~~.

Table [2827](#): Pin Descriptions – Power

Signal Name	Pin #	Baseboard Direction	Signal Description
GND	Various	GND	Ground return; a total of 46 ground pins are on the main 140-pin connector area. Additionally, a total of 4 ground pins are in the OCP bay area. Refer to Section 3.3 for details.
+12V_EDGE	B1, B2, B3, B4, B5, B6	Power	<p>+12_V main or +12_V aux power; total of 6 pins per connector. The +12V_EDGE pins shall be rated to 1.1_A per pin with a maximum derated power delivery of 80 W.</p> <p>The +12V_EDGE power pins shall be within the rail tolerances as defined in Section 3.93-10 when the PWR_EN pin is driven high by the baseboard.</p> <p>The OCP NIC 3.0 card may optionally implement a fuse on +12V_EDGE to protect against electrical faults.</p>
+3.3V_EDGE	B11	Power	<p>+3.3_V main or +3.3_V aux power; total of 1 pin per connector. The +3.3V_EDGE pin shall be rated to 1.1_A for a maximum derated power delivery of 3.63_W.</p> <p>The +3.3V_EDGE power pin shall be within the rail tolerances as defined in Section 3.93-10 when the PWR_EN pin is driven high by the baseboard.</p> <p>The OCP NIC 3.0 card may optionally implement a fuse on +3.3V_EDGE to protect against electrical faults.</p>
AUX_PWR_EN	B12	Output	<p>Aux Power enable. Active high.</p> <p>This pin indicates that the +12V_EDGE and +3.3V_EDGE power is from the baseboard aux power rails.</p> <p>This signal shall be pulled down to GND through a 10_kOhm resistor on the baseboard. This ensures the OCP NIC 3.0 card power is disabled until instructed to turn on by the baseboard.</p> <p>When low, the OCP NIC 3.0 card supplies running on aux power shall be disabled.</p>

			<p>When high, the OCP NIC 3.0 card supplies running on aux power shall be enabled.</p> <p>For OCP NIC 3.0 cards that do not use a separate “main power” domain circuitry (or can operate in a single power domain), the AUX_PWR_EN signal serves as the primary method to enable all the card power supplies.</p> <p>It is expected that a baseboard will not drive signals other than SMBus and the Scan Chain to the OCP NIC 3.0 card when this signal is low.</p>
MAIN_PWR_EN	OCP_B2	Output	<p>Main Power Enable. Active high.</p> <p>This pin indicates that the +12_EDGE and +3.3V_EDGE power is from the baseboard main power rails. Additionally, this signal notifies the OCP NIC 3.0 card to enable any power supplies that run only in the Main Power Mode.</p> <p>The MAIN_PWR_EN pin is driven by the baseboard. This pin must be implemented on baseboard systems, but may optionally be used by the OCP NIC 3.0 card depending on the end point silicon implementation. Depending on the silicon vendor, end point devices may be able to operate in a single power domain, or may require separate power domains to function.</p> <p>For baseboard implementations, this signal shall be pulled down to GND through a 10_kOhm resistor on the baseboard. This ensures the OCP NIC 3.0 card power is disabled until instructed to turn on by the baseboard.</p> <p>When low, the OCP NIC 3.0 card supplies running on main power shall be disabled.</p> <p>When high, the OCP NIC 3.0 card supplies running on main power shall be enabled.</p> <p>This pin may be left as a no connect for OCP NIC 3.0 cards that do not use a separate “main power” domain SVR circuitry.</p>
NIC_PWR_GOOD	OCP_B1	Input	<p>NIC Power Good. Active high. This signal is driven by the OCP NIC 3.0 card.</p> <p>The NIC_PWR_GOOD signal is used to indicate when the aux power domain, and main power domain rails are within operational tolerances.</p>

		<p>The truth table shows the expected NIC_PWR_GOOD state for power up sequencing depending on the values of AUX_PWR_EN and MAIN_PWR_EN.</p> <table border="1" data-bbox="574 506 1057 701"> <thead> <tr> <th>AUX_PWR_EN</th> <th>MAIN_PWR_EN</th> <th>NIC_PWR_GOOD Nominal Steady State Value</th> </tr> </thead> <tbody> <tr> <td>0</td> <td>0</td> <td>0</td> </tr> <tr> <td>1</td> <td>0</td> <td>1</td> </tr> <tr> <td>0</td> <td>1</td> <td>Invalid</td> </tr> <tr> <td>1</td> <td>1</td> <td>1</td> </tr> </tbody> </table> <p>Refer to the power up and power down sequencing diagrams (Figure 100Figure 94 and Figure 101Figure 95) for timing details.</p> <p>Where appropriate, designs that have a separate Main Power domain should also connect to the main power good indication to the NIC_PWR_GOOD signal via a FET to isolate the domains. Refer to Figure 83Figure 81 for an example implementation.</p> <p>When low, this signal shall indicate that the OCP NIC 3.0 card power supplies are not yet within nominal tolerances or are in a fault condition after the power ramp times (T_{APL} and T_{MPL}) have expired.</p> <p>For baseboards, this pin may be connected to the platform I/O hub as a NIC power health status indication. This signal shall be pulled down to ground with a 100_kOhm resistor on the baseboard to prevent a false power good indication if no OCP NIC 3.0 card is present.</p> <p>For OCP NIC 3.0 cards this signal shall indicate the OCP NIC 3.0 card power is “good” for the given power mode. This signal may be implemented by combinatorial logic, a cascaded power good tree or a discrete power good monitor output.</p> <p>When high, this signal should be treated as V_{REF} is available for NC-SI communications. Refer to timing parameter T4 in the DMTF DSP0222 specification for details.</p>	AUX_PWR_EN	MAIN_PWR_EN	NIC_PWR_GOOD Nominal Steady State Value	0	0	0	1	0	1	0	1	Invalid	1	1	1
AUX_PWR_EN	MAIN_PWR_EN	NIC_PWR_GOOD Nominal Steady State Value															
0	0	0															
1	0	1															
0	1	Invalid															
1	1	1															

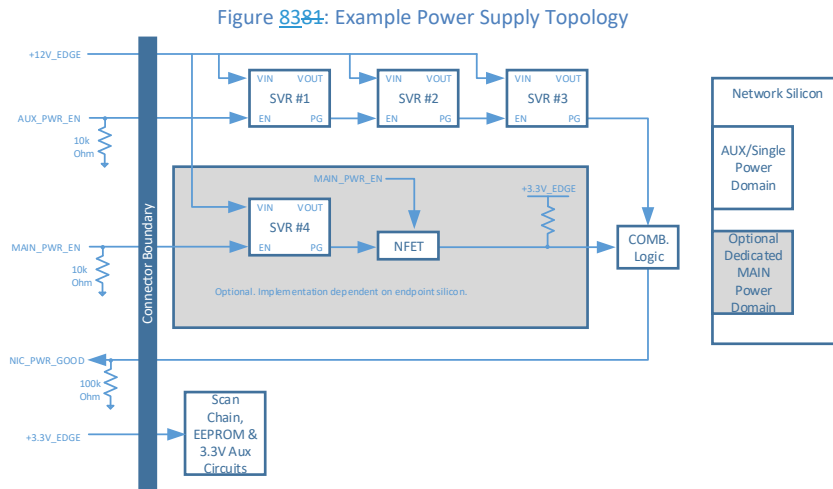

3.4.7 USB 2.0 (A68/A69) – Primary Connector Only

This section provides the pin assignments for the USB 2.0 interface signals. USB 2.0 is only defined for operation on the Primary Connector. USB 2.0 may be used for applications with end point silicon that requires a USB connection to the baseboard. Implementations may also allow for a USB-Serial or USB-JTAG translator for serial or JTAG applications. If multiple USB devices are required, an optional USB hub may be implemented on the OCP NIC 3.0 card. Downstream device discovery is completed as part of the bus enumeration per the USB 2.0 specification. A basic example connection diagram is shown in [Figure 84](#)[Figure 82](#). An example depicting USB-Serial and USB-JTAG connectivity with an USB hub is shown in [Figure 85](#)[Figure 83](#).

Table 2928: Pin Descriptions – USB 2.0 – Primary Connector only

Signal Name	Pin #	Baseboard Direction	Signal Description
USB_DATn USB_DATp	A68 A69	Bi-directional	<p>USB 2.0 Differential Pair – Primary Connector Only.</p> <p>A baseboard implementation shall provide a USB connection to the OCP NIC 3.0 primary connector.</p> <p>NIC implementations that require USB shall connect the bus to the end point silicon. This pin shall be left as a no connect if it is not used on the OCP NIC 3.0 card.</p> <p>The USB pins shall be directly connected between the end point silicon or USB device and the card gold fingers.</p>

		<p>The USB interface shall be based on a $V_{BUS} = 3.3V$. Both the baseboard and NIC device shall be capable of driving signals using 3.3_V logic. The OCP NIC 3.0 card may implement protection diodes and is up to the adapter vendor for placement.</p> <p>To prevent leakage paths, a baseboard shall not use USB pull up resistors on the USB_DATp/n lines to indicate the bus data transmission rate. If used, pull up resistors shall only exist on the NIC side.</p> <p>The AUX_PWR_EN signal may be used for downstream USB devices that require a V_{BUS} connection for host detection. Examples of this may include USB-serial converting devices.</p>
--	--	---

Figure 8482: USB 2.0 Connection Example – Basic Connectivity

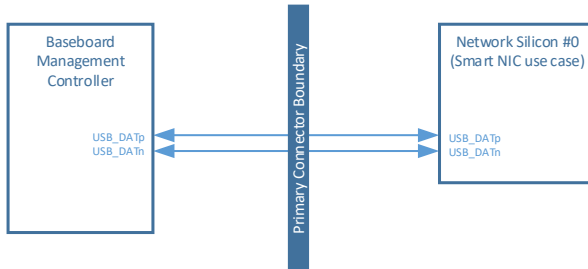
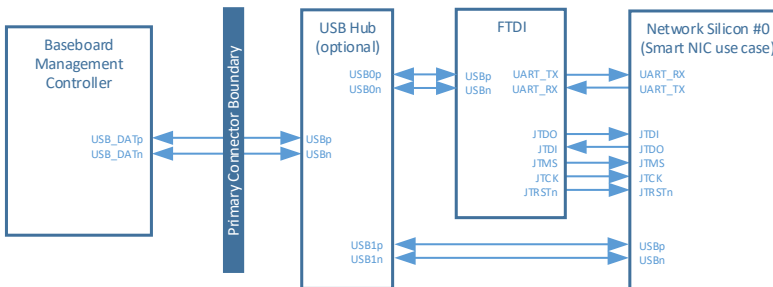

Figure 8583: USB 2.0 Connection Example – USB-Serial / USB-JTAG Connectivity



3.4.8 UART (A68/A69) – Secondary Connector Only

This section provides the pin assignments for the UART interface signals. UART is only defined for operation on the Secondary Connector. The UART pins may be used with end point silicon that require console redirection over the baseboard – such as ~~Large Form Factor LFF~~ SmartNICs. An example connection diagram is shown in ~~Figure 86~~Figure 84.

Table ~~3029~~: Pin Descriptions – UART – Secondary Connector Only

Signal Name	Pin #	Baseboard Direction	Signal Description
UART_RX	A68	Input	<p>UART Receive. +3.3_V signaling levels. Secondary Connector Only.</p> <p>A baseboard implementations shall provide a UART receive connection from the OCP NIC 3.0 connector. The UART_RX pin shall be pulled up to +3.3_V_{AUX} on the baseboard to prevent erroneous data reception when the OCP NIC 3.0 card is powered off or not present.</p> <p>NIC implementations that require a UART shall connect the network silicon UART_RX pin to the UART_TX pin on the OCP NIC 3.0 connector. This pin shall be left as a no connect if it is not used on the OCP NIC 3.0 card.</p> <p>The UART_RX pin shall be buffered on the NIC to prevent a leakage path into unpowered silicon when the card is in ID Mode. The buffer may be controlled via a local “Power Good” indicator.</p>
UART_TX	A69	Output	<p>UART Transmit. +3.3_V signaling levels. Secondary Connector Only.</p> <p>A baseboard implementation shall provide a UART transmit connection to the OCP NIC 3.0 connector.</p> <p>NIC implementations that require a UART shall connect the UART_TX pin from the OCP NIC 3.0 connector to the target silicon UART_RX pin. This pin shall be left as a no connect if it is not used on the OCP NIC 3.0 card.</p> <p>The UART_TX pin shall be buffered on the NIC to prevent a leakage path into unpowered silicon when the card is in ID Mode. The buffer may be controlled via a local “Power Good” indicator.</p>

Figure 8684: UART Connection Example

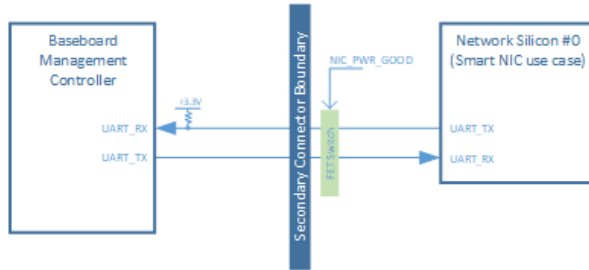

3.4.9 RFU[1:24] Pins

This section provides the pin assignments for the RFU[1:24] interface signals.

Table ~~3130~~: Pin Descriptions – RFU[1:24]

Signal Name (Primary / Secondary)	Pin #	Baseboard Direction	Signal Description
RFU1 / RFU3, N/C	B68	Input / Output	Reserved future use pins. These pins shall be left as no connect. These pins may also be used as a differential pair for future implementations. In this release of the OCP NIC 3.0 specification, the RFU[1:2] pins are defined on both the Primary Connector. RFU[3:4] are defined on and the Secondary Connector in this release of the OCP NIC 3.0 specification. A total of two reserved pins are available for the SFF; a total of four reserved pins are available the LFF.
RFU2 / RFU4, N/C	B69		

3.5 PCIe Bifurcation Mechanism

OCP NIC 3.0 baseboards and OCP NIC 3.0 cards support multiple bifurcation combinations. Single socket baseboards with a single or multiple root ports, as well as a multi-socket baseboards with a single or multiple root ports are supported. The bifurcation mechanism also supports OCP NIC 3.0 cards with a single or multiple end points. These features are accomplished via I/O pins on the Primary and Secondary Connector:

- PRSNTA#, PRSNTB[3:0]#. The PRSNTA# pin shall connect to the PRSNTB# pins as a hard coded value on the OCP NIC 3.0 card. The encoding of the PRSNTB[3:0]# pins allows the baseboard to determine the PCIe Links available on the OCP NIC 3.0 card. [PRSNTA# and PRSNTB\[3:0\]# pins exist for each connector. For the SFF, a baseboard shall read the pins associated with the Primary Connector to determine the card type. For the LFF, a baseboard shall read the pins associated with both the Primary and Secondary Connector to determine the card type.](#)
- BIF[3:0]#. The BIF# pin states shall be controlled by the baseboard to allow the baseboard to override the default end point bifurcation for silicon that support bifurcation. Additional combinatorial logic is required and is specific to the card silicon. The combinatorial logic is not covered in this specification. The BIF[3:0]# pins may optionally be hardcoded for baseboards that do not require a dynamic bifurcation override. [BIF\[2:0\]# pins exist on each connector.](#)

A high level bifurcation connection diagram is shown in [Figure 76](#)~~Figure-74~~.

3.5.1 PCIe OCP NIC 3.0 Card to Baseboard Bifurcation Configuration (PRSNTA#, PRSNTB[3:0]#)

The OCP NIC 3.0 card to baseboard configuration mechanism consists of four dual use pins (PRSNTB[3:0]#) on the OCP NIC 3.0 card and a grounded PRSNTA# pin on the baseboard [per connector](#). [For the SFF, a baseboard shall read the pins associated with the Primary Connector to determine the card type. For the LFF, a baseboard shall read the pins associated with both the Primary and Secondary Connector to determine the card type.](#) These pins provide card presence detection as well as mechanism to notify the baseboard of the pre-defined PCIe lane width capabilities. The PRSNTB[3:0]# pins are pulled up to +3.3V_EDGE on the baseboard and are active low signals. A state of 0b1111 indicates that no card is present [in the system in the connector\(s\)](#). Depending on the capabilities of the OCP NIC 3.0 card, a selection of PRSNTB[3:0]# signals may be strapped to the PRSNTA# signal and is pulled low by the baseboard. The encoding of the PRSNTB[3:0]# bits is shown in [Table 32](#)~~Table 31~~ for [x32, x16 and x8 PCIe cards](#). [While SFF and LFF cards are allowed in an LFF compliant slot, the condition where the Primary Connector PRSNTB\[3:0\]# equals 0b1111 and the Secondary Connector PRSNTB\[3:0\]# pins is not equal to 0b1111 is invalid.](#)

3.5.2 PCIe Baseboard to OCP NIC 3.0 Card Bifurcation Configuration (BIF[2:0]#)

Three signals (BIF[2:0]#) are driven by the baseboard to notify requested bifurcation on the OCP NIC 3.0 card silicon. This allows the baseboard to set the lane configuration on the OCP NIC 3.0 card that supports multiple bifurcation options. [BIF\[2:0\]# pins exist on each connector. For the SFF, the BIF\[2:0\]# pins associated with the Primary Connector are used. For the LFF, the BIF\[2:0\]# pins associated with both the Primary and Secondary Connector are used to determine the requested bifurcation.](#)

For example, a baseboard that has four separate hosts that support a 4 x4 connection, should appropriately drive the BIF[2:0]# pins per ~~Table 32~~~~Table 31~~ and indicate to the [SFF](#) OCP NIC 3.0 card silicon to setup a 4 x4 configuration.

As previously noted, the BIF[2:0]# signals require additional combinatorial logic to decode the BIF[2:0]# value and appropriately apply it to the end-point silicon. The combinatorial logic is not covered in the specification as its implementation is specific to the vendor silicon used.

3.5.3 PCIe Bifurcation Decoder

The combination of the PRSNTB[3:0]# and BIF[2:0]# pins deterministically sets the PCIe lane width for a given combination of baseboard and OCP NIC 3.0 cards. ~~Table 32~~~~Table 31~~ shows the resulting number of PCIe links and its width for known combinations of baseboards and OCP NIC 3.0 cards. [A copy of this bifurcation decoder is also available on the OCP NIC 3.0 Wiki site. Please refer to: <https://www.opencompute.org/wiki/Server/Mezz>.](#)

Note 1: The baseboard must disable PCIe lanes during the initialization phase if the number of detected PCIe links are greater than what is supported on the baseboard to prevent a nondeterministic solution. For example, if the baseboard only supports a 1 x16 connection, and the OCP NIC 3.0 card only supports a 2 x8 connection, the baseboard must disable PCIe lanes 8-15 to prevent any potential LTSSM issues during the discovery phase.

Note 2: Due to separate PCIe REFCLKs and power state timing differences in multi-host configurations, ~~Table 32~~~~Table 31~~ shows the expected resulting links for a given baseboard and OCP NIC 3.0 card combination.

Table ~~3234~~: PCIe Bifurcation Decoder for ~~x32, x16, and~~ x8, x4, x2 and x1 Card Widths

Part	Card Short	Supported (Blade/Port/Slot)	Primary Connector (Blade/Port/Slot)	Secondary Connector (Blade/Port/Slot)	Hosts →	Hosts	Single Host	Hosts	Hosts	Hosts	Hosts	Hosts	Hosts	Hosts	Hosts	Hosts	Hosts	Hosts		
Network Card - Supported PCI Configurations	SFF	1x8 Opsion A	1x8, 1x4, 1x2, 1x1	0x1110	0x1110 (not used)	1x8	1x8 (Socket only)	1x8	1x8	1x8	1x8	1x8	1x8	1x8	1x8	1x8	1x8	1x8	1x8	
	SFF	1x4	1x4, 1x2, 1x1	0x1110	0x1110 (not used)	1x4	1x4 (Socket only)	1x4	1x4	1x4	1x4	1x4	1x4	1x4	1x4	1x4	1x4	1x4	1x4	
	SFF	1x2	1x2, 1x1	0x1110	0x1110 (not used)	1x2	1x2 (Socket only)	1x2	1x2	1x2	1x2	1x2	1x2	1x2	1x2	1x2	1x2	1x2	1x2	
	SFF	1x1	1x1	0x1110	0x1110 (not used)	1x1	1x1 (Socket only)	1x1	1x1	1x1	1x1	1x1	1x1	1x1	1x1	1x1	1x1	1x1	1x1	
	SFF	1x8 Opsion B	1x8, 1x4, 1x2, 1x1	0x1110	0x1110 (not used)	1x8	1x8 (Socket only)	1x8	1x8	1x8	1x8	1x8	1x8	1x8	1x8	1x8	1x8	1x8	1x8	
	SFF	2x8 Opsion B	2x8, 2x4, 2x2, 2x1	0x1110	0x1110 (not used)	2x8, 2x4, 2x2, 2x1	2x8, 2x4, 2x2, 2x1 (Socket only)	2x8, 2x4, 2x2, 2x1	2x8, 2x4, 2x2, 2x1	2x8, 2x4, 2x2, 2x1	2x8, 2x4, 2x2, 2x1	2x8, 2x4, 2x2, 2x1	2x8, 2x4, 2x2, 2x1	2x8, 2x4, 2x2, 2x1	2x8, 2x4, 2x2, 2x1	2x8, 2x4, 2x2, 2x1	2x8, 2x4, 2x2, 2x1	2x8, 2x4, 2x2, 2x1	2x8, 2x4, 2x2, 2x1	2x8, 2x4, 2x2, 2x1
	SFF	2x8 Opsion C	4x4, 4x2, 4x1	0x1110	0x1110 (not used)	4x4, 4x2, 4x1	4x4, 4x2, 4x1 (Socket only)	4x4, 4x2, 4x1	4x4, 4x2, 4x1	4x4, 4x2, 4x1	4x4, 4x2, 4x1	4x4, 4x2, 4x1	4x4, 4x2, 4x1	4x4, 4x2, 4x1	4x4, 4x2, 4x1	4x4, 4x2, 4x1	4x4, 4x2, 4x1	4x4, 4x2, 4x1	4x4, 4x2, 4x1	4x4, 4x2, 4x1
	SFF	1x8 Opsion D	4x4, 4x2, 4x1, 4x1	0x1110	0x1110 (not used)	1x8	1x8 (Socket only)	1x8	1x8	1x8	1x8	1x8	1x8	1x8	1x8	1x8	1x8	1x8	1x8	1x8
	SFF	1x8 Opsion E	4x4, 4x2, 4x1, 4x1	0x1110	0x1110 (not used)	1x8	1x8 (Socket only)	1x8	1x8	1x8	1x8	1x8	1x8	1x8	1x8	1x8	1x8	1x8	1x8	1x8
	SFF	2x4	2x4, 2x2, 2x1	0x1110	0x1110 (not used)	2x4	2x4 (Socket only)	2x4	2x4	2x4	2x4	2x4	2x4	2x4	2x4	2x4	2x4	2x4	2x4	2x4
	Network Card - Supported PCI Configurations	SFF	4x2	4x2, 2x4, 2x2, 2x1	0x1110	0x1110 (not used)	4x2	4x2 (Socket only)	4x2	4x2	4x2	4x2	4x2	4x2	4x2	4x2	4x2	4x2	4x2	4x2
		RSUD	1x8 Opsion A	1x8, 1x4, 1x2, 1x1	0x1110	0x1110 (not used)	1x8	1x8 (Socket only)	1x8	1x8	1x8	1x8	1x8	1x8	1x8	1x8	1x8	1x8	1x8	1x8
SFF		1x8 Opsion A	2x8, 2x4, 2x2, 2x1	0x1110	0x1110 (not used)	1x8	1x8 (Socket only)	1x8	1x8	1x8	1x8	1x8	1x8	1x8	1x8	1x8	1x8	1x8	1x8	
SFF		1x8 Opsion B	1x8, 1x4, 1x2, 1x1	0x1110	0x1110 (not used)	1x8	1x8 (Socket only)	1x8	1x8	1x8	1x8	1x8	1x8	1x8	1x8	1x8	1x8	1x8	1x8	1x8
SFF		2x8 Opsion B	2x8, 2x4, 2x2, 2x1	0x1110	0x1110 (not used)	2x8	2x8 (Socket only)	2x8	2x8	2x8	2x8	2x8	2x8	2x8	2x8	2x8	2x8	2x8	2x8	2x8
SFF		1x8 Opsion C	4x4, 4x2, 4x1	0x1110	0x1110 (not used)	1x8	1x8 (Socket only)	1x8	1x8	1x8	1x8	1x8	1x8	1x8	1x8	1x8	1x8	1x8	1x8	1x8
SFF		4x4	4x4, 2x8, 2x4, 2x2, 2x1	0x1110	0x1110 (not used)	4x4	4x4 (Socket only)	4x4	4x4	4x4	4x4	4x4	4x4	4x4	4x4	4x4	4x4	4x4	4x4	4x4
SFF		2x8 Opsion A	4x8, 4x4, 4x2, 4x1	0x1110	0x1110	2x8	2x8 (Socket only)	2x8	2x8	2x8	2x8	2x8	2x8	2x8	2x8	2x8	2x8	2x8	2x8	2x8
SFF		4x8 Opsion A	4x8, 4x4, 4x2, 4x1	0x1110	0x1110	4x8	4x8 (Socket only)	4x8	4x8	4x8	4x8	4x8	4x8	4x8	4x8	4x8	4x8	4x8	4x8	4x8
SFF		2x8 Opsion B	2x8, 2x4, 2x2, 2x1	0x1110	0x1110	2x8	2x8 (Socket only)	2x8	2x8	2x8	2x8	2x8	2x8	2x8	2x8	2x8	2x8	2x8	2x8	2x8
SFF		2x8 Opsion C	4x4, 4x2, 4x1	0x1110	0x1110	2x8	2x8 (Socket only)	2x8	2x8	2x8	2x8	2x8	2x8	2x8	2x8	2x8	2x8	2x8	2x8	2x8
RSUD		RSUD	RSUD	4x4, 2x8, 2x4, 2x2, 2x1	0x1110	0x1110 (not used)	4x4	4x4 (Socket only)	4x4	4x4	4x4	4x4	4x4	4x4	4x4	4x4	4x4	4x4	4x4	4x4
RSUD	RSUD	RSUD	1x8, 1x4, 1x2, 1x1	0x1110	0x1110	1x8	1x8 (Socket only)	1x8	1x8	1x8	1x8	1x8	1x8	1x8	1x8	1x8	1x8	1x8	1x8	
SFF	1x32 Opsion B	2x8, 2x4, 2x2, 2x1	0x1110	0x1110	1x32	1x32 (Socket only)	1x32	1x32	1x32	1x32	1x32	1x32	1x32	1x32	1x32	1x32	1x32	1x32	1x32	
SFF	1x32 Opsion C	1x8, 1x4, 1x2, 1x1	0x1110	0x1110	1x32	1x32 (Socket only)	1x32	1x32	1x32	1x32	1x32	1x32	1x32	1x32	1x32	1x32	1x32	1x32	1x32	

Minimum Required Edge	Network Card - Supported PCIe Configurations	Single Host				Quad Host				Quad Host			
		1 Host	2 Hosts	4 Hosts	8 Hosts	2 Hosts	4 Hosts	8 Hosts	16 Hosts	2 Hosts	4 Hosts	8 Hosts	16 Hosts
1x8 Option A	1x8 Option A	1x8	1x8	1x8	1x8	1x8	1x8	1x8	1x8	1x8	1x8	1x8	1x8
1x4	1x4	1x4	1x4	1x4	1x4	1x4	1x4	1x4	1x4	1x4	1x4	1x4	1x4
1x2	1x2	1x2	1x2	1x2	1x2	1x2	1x2	1x2	1x2	1x2	1x2	1x2	1x2
1x1	1x1	1x1	1x1	1x1	1x1	1x1	1x1	1x1	1x1	1x1	1x1	1x1	1x1
2x8 Option B	2x8 Option B	2x8	2x8	2x8	2x8	2x8	2x8	2x8	2x8	2x8	2x8	2x8	2x8
2x4	2x4	2x4	2x4	2x4	2x4	2x4	2x4	2x4	2x4	2x4	2x4	2x4	2x4
4x2 Option D	4x2 Option D	4x2	4x2	4x2	4x2	4x2	4x2	4x2	4x2	4x2	4x2	4x2	4x2
RSVD	RSVD	RSVD	RSVD	RSVD	RSVD	RSVD	RSVD	RSVD	RSVD	RSVD	RSVD	RSVD	RSVD
2C	2C	2C	2C	2C	2C	2C	2C	2C	2C	2C	2C	2C	2C
4C	4C	4C	4C	4C	4C	4C	4C	4C	4C	4C	4C	4C	4C
8C	8C	8C	8C	8C	8C	8C	8C	8C	8C	8C	8C	8C	8C
16C	16C	16C	16C	16C	16C	16C	16C	16C	16C	16C	16C	16C	16C

3.5.4 Bifurcation Detection Flow

The following detection flow shall be used to determine the resulting link count and lane width based on the baseboard and OCP NIC 3.0 card configurations.

1. The baseboard shall read the state of the PRSNTB[3:0]# pins [for the Primary Connector and Secondary Connector \(if applicable\)](#). An OCP NIC 3.0 card is present in the system if the resulting value is not 0b1111 [on the Primary Connector](#).
2. Firmware determines the OCP NIC 3.0 card PCIe lane width capabilities per [Table 32](#)~~Table 34~~ by reading the PRSNTB[3:0]# pins.
3. The baseboard reconfigures the PCIe bifurcation on its ports to match the highest common lane width and lowest common link count on the card.
4. For cases where the baseboard request a link count override (such as requesting a 4-host baseboard requesting 4 x4 operation on a supported card that would otherwise default to a 2 x8 case), the BIF[0:2]# pins shall be asserted as appropriate. Asserting the BIF[0:2]# pins assumes the OCP NIC 3.0 card supports the requested link override.

- o [Note: For cards that are already powered up, BIF\[0:2\]# reconfiguration requires a transition back to ID Mode. During this transition, the card power rails are inactive and manageability links may be briefly lost due to the RBT isolation state.](#)

~~4-5~~ The BIF[0:2]# pins must be in their valid states upon the assertion of AUX_PWR_EN.

~~5-6~~ AUX_PWR_EN is asserted. An OCP NIC 3.0 card is allowed a max ramp time T_{APL} between AUX_PWR_EN assertion and NIC_PWR_GOOD assertion.

~~6-7~~ MAIN_PWR_EN is asserted. An OP NIC 3.0 card is allowed a max ramp time T_{MPL} between MAIN_PWR_EN assertion and NIC_PWR_GOOD reassertion. For cards that do not have a separate AUX and MAIN power domain, this state is an unconditional transition to NIC_PWR_GOOD.

~~7-8~~ The PCIe REFCLK shall become valid a minimum of 100 μ s before the deassertion of PERST#.

~~8-9~~ PERST# shall be deasserted >1s after NIC_PWR_GOOD assertion as defined in [Figure 100](#)~~Figure~~

[94](#). Refer to Section [3.11](#)~~3-12~~ for timing details.

Commented [PH4]: For this use case when the system is up, i.e user setup to request link count override, the management interface would be lost momentarily if system toggle AUX_PWR_EN. This has negative end user experience for cards with single power domain. Seeking NIC vendors feedback on ways to eliminate this negative effect. This negative side effect should be spec/describe if there is not a solution.

3.5.5 PCIe Bifurcation Examples

For illustrative purposes, the following figures show several common bifurcation permutations [using a SFF](#).

3.5.5.1 Single Host (1 x16) Baseboard with a 1 x16 OCP NIC 3.0 Card (Single Controller)

[Figure 87](#)[Figure 85](#) illustrates a single host baseboard that supports x16 with a single controller OCP NIC 3.0 card that also supports x16. The PRSTNB[3:0]# state is 0b0111. The BIF[2:0]# state is 0b000 to set the card as a 1x16 for bifurcation capable controllers. For controllers without bifurcation support, the BIF[2:0] pin connections are not required on the card. The PRSNTB encoding notifies the baseboard that this card is only capable of 1 x16. The single host baseboard determines that it is also capable of supporting 1 x16. The resulting link width is 1 x16.

Figure 8785: Single Host (1 x16) and 1 x16 OCP NIC 3.0 Card (Single Controller)

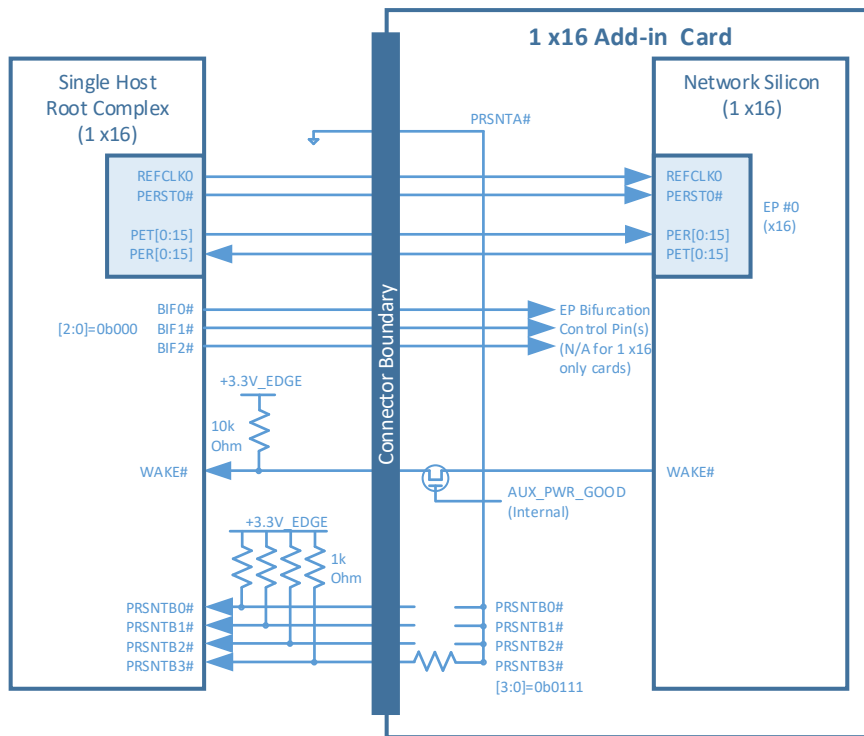

3.5.5.2 Single Host (2 x8) Baseboard with a 2 x8 OCP NIC 3.0 Card (Dual Controllers)

Figure 88 illustrates a single host baseboard that supports 2 x8 with a single controller OCP NIC 3.0 card that also supports 2 x8 with dual controllers. The PRSTNB[3:0]# state is 0b0110. The BIF[2:0]# state is 0b000 in this example because the network card only supports a 2x8. The PRSNTB encoding notifies the baseboard that this card is only capable of 2 x8. The single host baseboard determines that it is also capable of supporting 2 x8. The resulting link width is 2 x8.

Figure 88: Single Host (2 x8) and 2 x8 OCP NIC 3.0 Card (Dual Controllers)

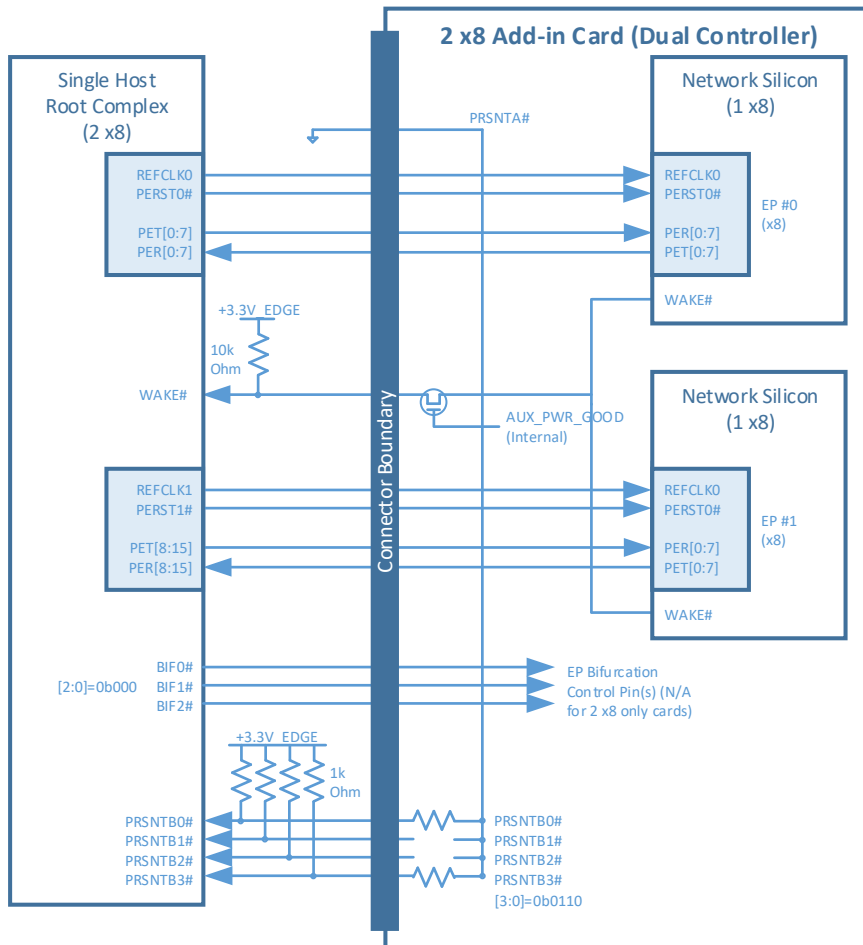

3.5.5.3 Quad Host (4 x4) Baseboard with a 4 x4 OCP NIC 3.0 Card (Single Controller)

Figure 8987 illustrates a quad host baseboard that supports 4 x4 with a single controller OCP NIC 3.0 card that supports 1 x16, 2 x8 and 4 x4. The PRSTNB[3:0]# state is 0b0100. The BIF[2:0]# state in this example is 0b110 as the end point network controller is forced to bifurcate to 4 x4. The PRSNTB encoding notifies the baseboard that this card is only capable of 1 x16, 2 x8 and 4 x4. The quad host baseboard determines that it is also capable of supporting 4 x4. The resulting link width is 4 x4.

Figure 8987: Quad Hosts (4 x4) and 4 x4 OCP NIC 3.0 Card (Single Controller)

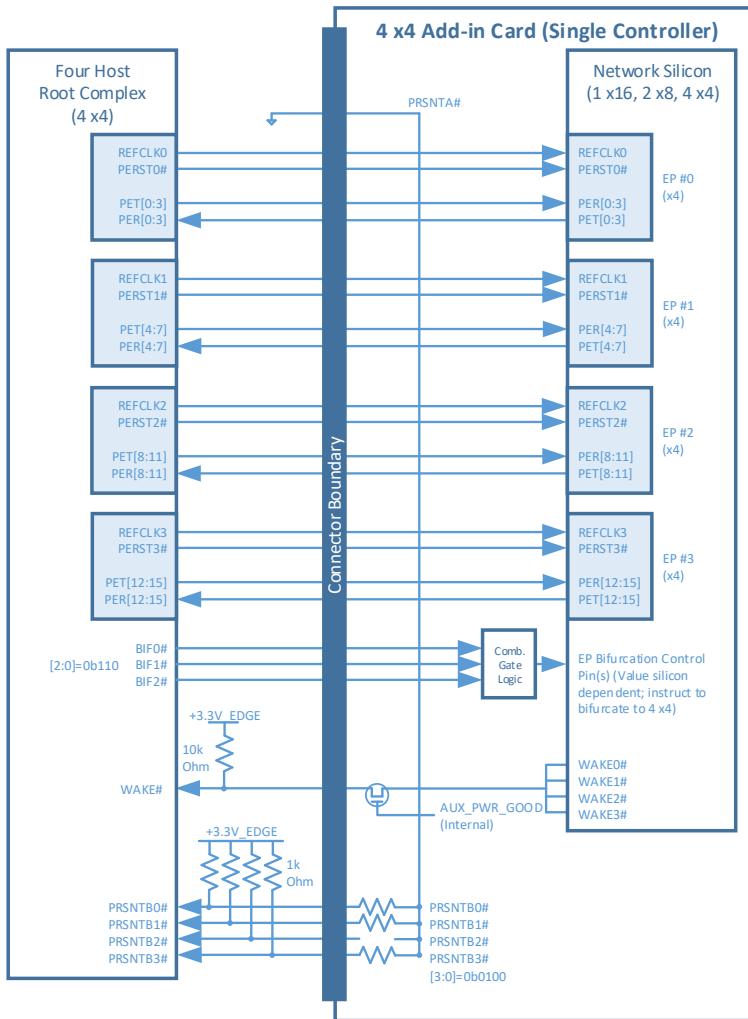

3.5.5.4 Quad Host (4 x4) Baseboard with a 4 x4 OCP NIC 3.0 Card (Quad Controllers)

Figure 90 illustrates a quad host baseboard that supports 4 x4 with a quad controller OCP NIC 3.0 card that supports 4 x4. The PRSTNB[3:0]# state is 0b0011. The BIF[2:0]# state is a don't care value as there is no need to instruct the end-point network controllers to a specific bifurcation (each controller only supports 1x4 in this example). The PRSNTB encoding notifies the baseboard that this card is only capable of 4 x4. The quad host baseboard determines that it is also capable of supporting 4 x4. The resulting link width is 4 x4.

Figure 90: Quad Hosts (4 x4) and 4 x4 OCP NIC 3.0 Card (Quad Controllers)

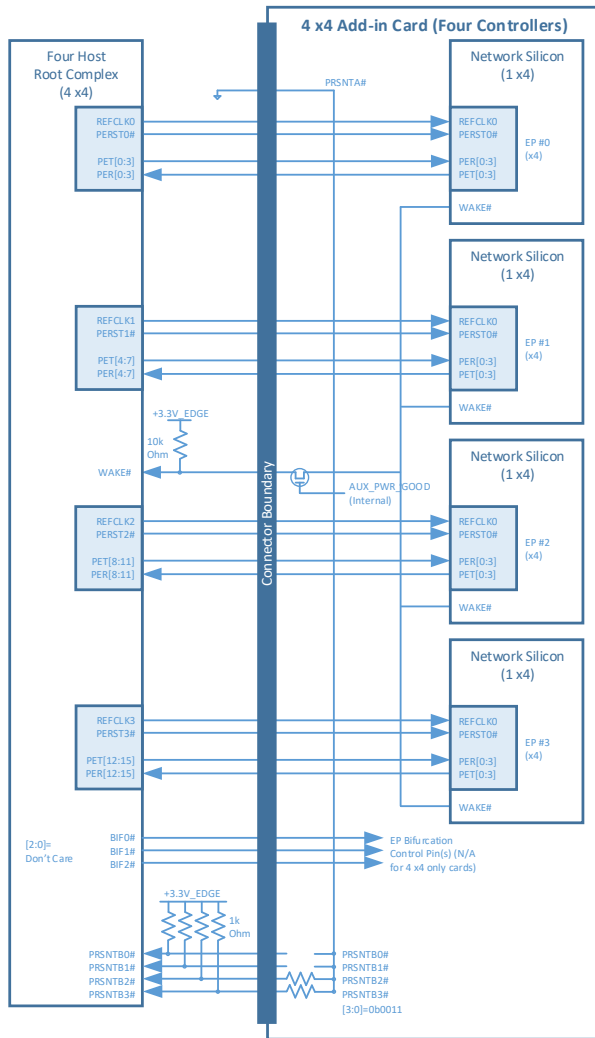

3.5.5.5 Single Host (1 x16, no Bifurcation) Baseboard with a 2 x8 OCP NIC 3.0 Card (Dual Controller)

Figure 91 illustrates a single host baseboard that supports 1 x16 with a dual controller OCP NIC 3.0 card that supports 2 x8. The PRSTNB[3:0]# state is 0b0110. The BIF[2:0]# state is 0b000 as each silicon instance only supports 1x8. The PRSNTB encoding notifies the baseboard that this card is only capable of 2 x8. The quad host baseboard determines that it is capable of 1x 16, but down shifts to 1 x8. The resulting link width is 1 x8 and only on endpoint 0.

Figure 91: Single Host with no Bifurcation (1 x16) and 2 x8 OCP NIC 3.0 Card (Dual Controllers)

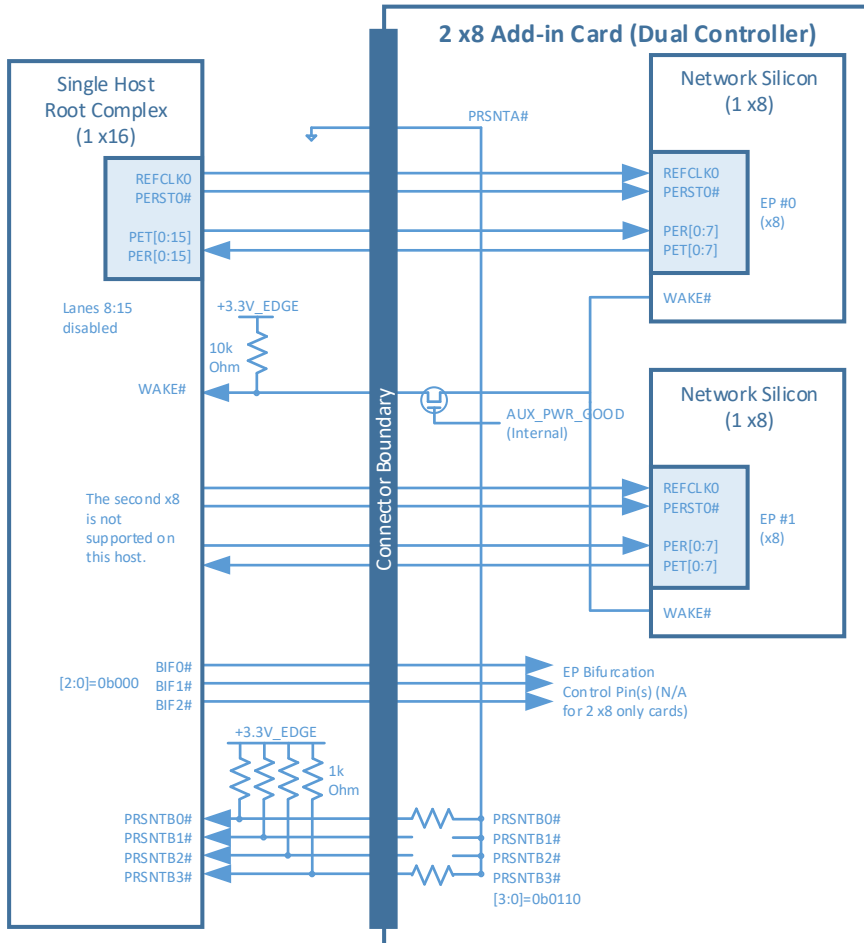

3.6 PCIe REFCLK and PERST# Clocking Topology Mapping

The OCP NIC 3.0 specification allows for up to four PCIe REFCLKs and PERST# signals on the Primary Connector and up to two PCIe REFCLKs and PERST# signals on the Secondary Connector. In general, the association of each REFCLK and PERST# is based on the card PCIe Link number on a per connector basis and is shown in Table 33-Table 32. Cards that implement both the Primary and Secondary Connectors have a total of up to 6 available REFCLKs and 6 PERST# signals.

REFCLK[0:3] and PERST[0:3]# are defined for use in this release of the specification. REFCLK[4:5] and PERST[4:5]# are not currently defined for use. The following tables enumerate the REFCLK and PERST# mapping for SFF cards for 1, 2 and 4 links; LFF cards for 1, 2, 4 and 8 links. For a LFF 8 link scenario, the lower x4 “link-a” and upper x4 “link-b” of each x8 lanes are expected to use the same REFCLK and PERST (see Table 35). A 1:2 clock driver circuit is expected on the OCP NIC 3.0 card in this case.

For multi-host use cases, the baseboard may require a multiplexer circuit to direct the Host 1, Host 2 PCIe reference clock to the connector REFCLK1 signal to maintain proper REFCLK associations for a card with two links. Refer to the diagrams in Sections 3.6.1 and 3.6.2.

Table 33: PCIe Clock-REFCLK and PERST Associations

REFCLK #	PERST #	Description	Availability (Connector)
REFCLK0	PERST0#	REFCLK-0 associated with Link 0.	Primary and Secondary Connectors only.
REFCLK1	PERST1#	REFCLK-1 associated with Link 1.	Primary and Secondary Connectors only.
REFCLK2	PERST2#	REFCLK-2 associated with Link 2.	Primary Connector only.
REFCLK3	PERST3#	REFCLK-3 associated with Link 3.	Primary Connector only.
REFCLK4	PERST4#	Not used.	Secondary Connector only.
REFCLK5	PERST5#	Not used.	Secondary Connector only.

Table 34: SFF PCIe Link / REFCLKn / PERSTn mapping for 1, 2 and 4 Links

Primary Connector			
Lanes [0:3]	Lanes [4:7]	Lanes [8:11]	Lanes [12:15]
Link 0 – x16, REFCLK0, PERST0#			
Link 0 – x8, REFCLK0, PERST0#		Link 1 – x8, REFCLK1, PERST1#	
Link 0 – x4, REFCLK0, PERST0#	Link 1 – x4, REFCLK1, PERST1#	Link 2 – x4, REFCLK2, PERST2#	Link 3 – x4, REFCLK3, PERST3#

Table 35: LFF PCIe Link / REFCLKn / PERSTn mapping for 1, 2, 4 and 8 Links

Primary Connector				Secondary Connector			
Lanes [0:3]	Lanes [4:7]	Lanes [8:11]	Lanes [12:15]	Lanes [16:19]	Lanes [20:23]	Lanes [24:27]	Lanes [28:31]
Link 0 – x32, REFCLK0, PERST0#				Link 1 – x16, REFCLK1, PERST1#			
Link 0 – x8, REFCLK0, PERST0#		Link 1 – x8, REFCLK1, PERST1#		Link 2 – x8, REFCLK2, PERST2#		Link 3 – x8, REFCLK3, PERST3#	
Link 0a – x4, REFCLK0, PERST0#	Link 0b – x4, REFCLK0, PERST0#	Link 1a – x4, REFCLK1, PERST1#	Link 1b – x4, REFCLK1, PERST1#	Link 2a – x4, REFCLK2, PERST2#	Link 2b – x4, REFCLK2, PERST2#	Link 3a – x4, REFCLK3, PERST3#	Link 3b – x4, REFCLK3, PERST3#

3.6.1 SFF PCIe REFCLK and PERST# Mapping

The following figures show the Link n, REFCLKn, PERSTn mapping for the SFF with 1, 2 and 4 links as single, dual and quad host configurations. For clarity, the PCIe sideband signals are not illustrated this section. Please refer to the signal descriptions and associated diagrams for connectivity requirements.

For each OCP NIC 3.0 card, the following REFCLK connection rules must be followed:

For a 1 x16 capable OCP NIC 3.0 card, REFCLK0 shall be used for lanes [0:15].

For a 2 x8 capable OCP NIC 3.0 card, REFCLK0 shall be used for lanes [0:7] and REFCLK1 shall be used for lanes [8:15].

For a 4 x4 capable OCP NIC 3.0 card, REFCLK0 shall be used for lanes [0:3], REFCLK1 shall be used for lanes [4:7], REFCLK2 shall be used for lanes [8:11] and REFCLK3 shall be used for lanes [12:15]. Pins for REFCLK2 and REFCLK3 are located on the 28-pin OCP bay.

Figure 92: SFF PCIe REFCLK Mapping – Single Host – 1, 2 and 4 links

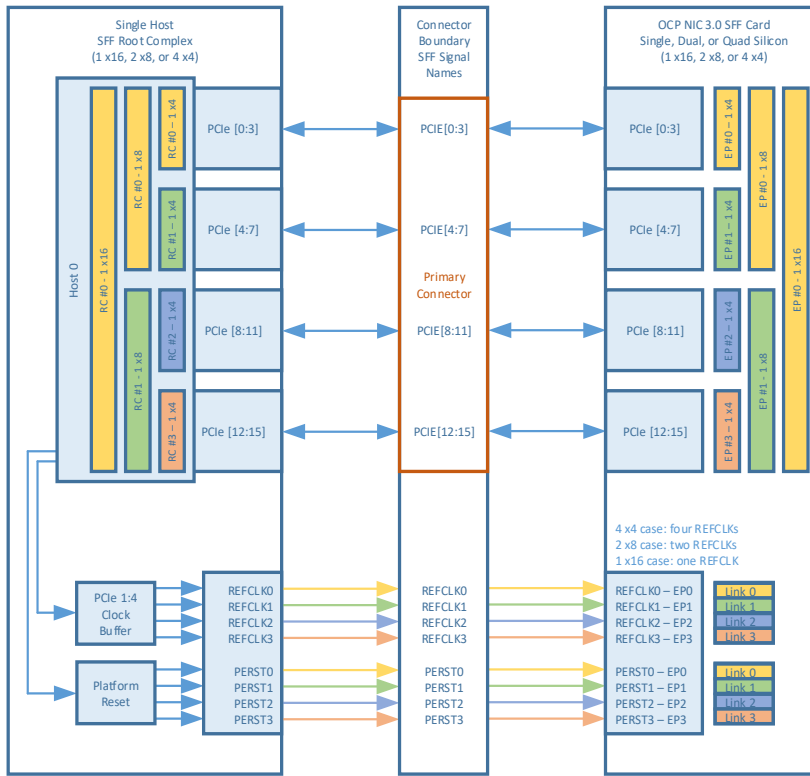

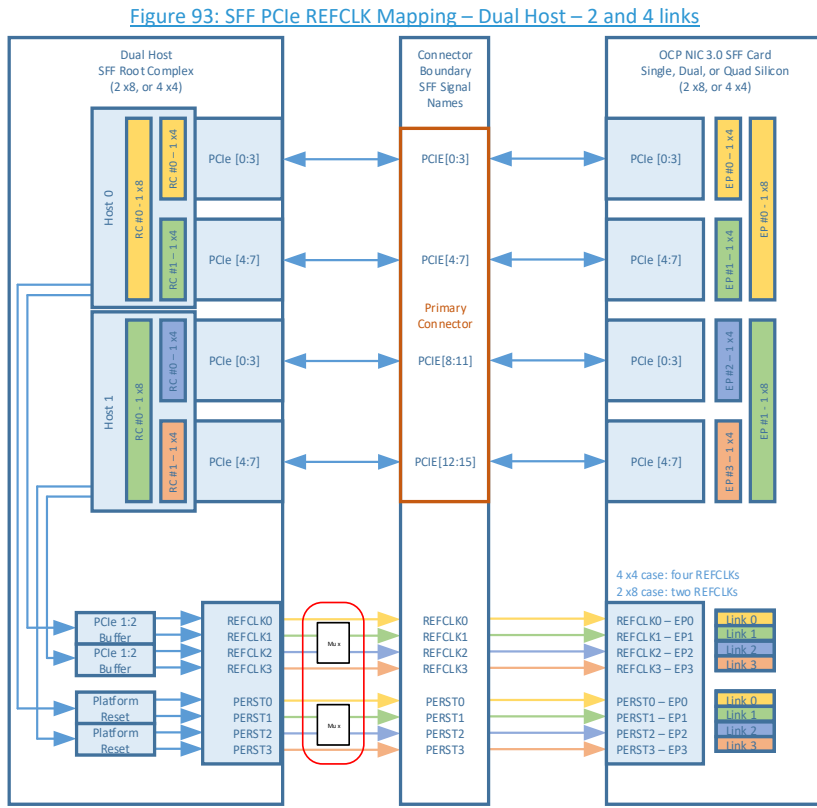

Note: For dual host applications that connect to a two link endpoint, the baseboard Host 1 REFCLK0 and PERST0 signal needs to be multiplexed to the REFCLK1 and PERST1 pins of the OCP NIC 3.0 card edge. This ensures the mandated Link n, REFCLKn and PERSTn mappings are maintained.

Figure 94: SFF PCIe REFCLK Mapping – Quad Host – 4 Links

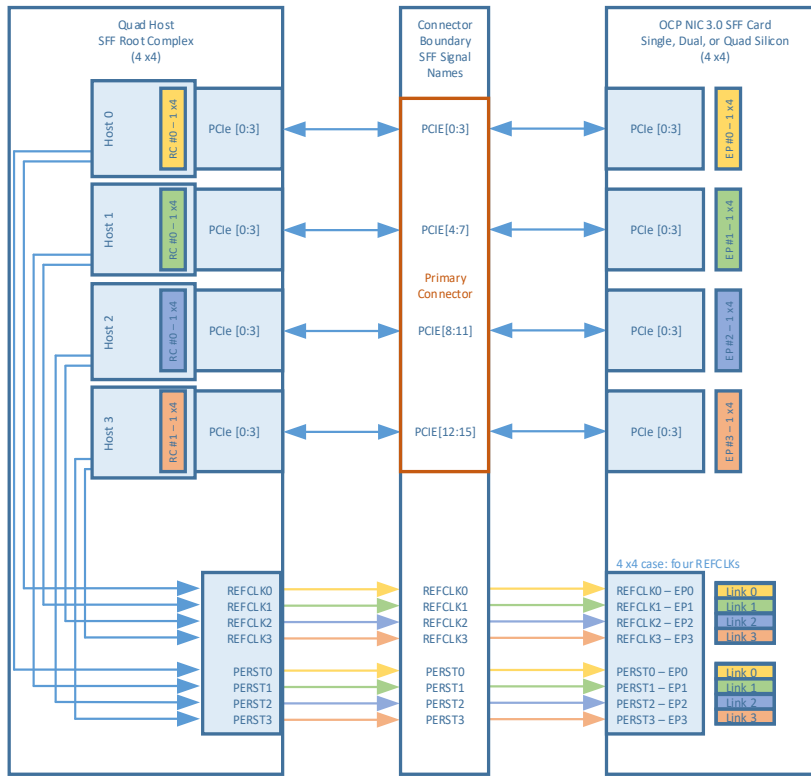

Note: For quad host applications that connect to a two link endpoint, the baseboard Host 2 REFCLK and PERST signal needs to be multiplexed to the REFCLK1 and PERST1 pins of the OCP NIC 3.0 card edge. This ensures the mandated Link n, REFCLKn and PERSTn mappings are maintained.

3.6.2 LFF PCIe REFCLK and PERST# Mapping

The following figures show the Link n, REFCLKn, PERSTn mapping for the LFF with 1, 2 and 4 links as single, dual and quad host configurations. For clarity, the PCIe sideband signals are not illustrated this section. Please refer to the signal descriptions and associated diagrams for connectivity requirements.

Figure 95: LFF PCIe REFCLK Mapping – Single Host – 1, 2 and 4 links

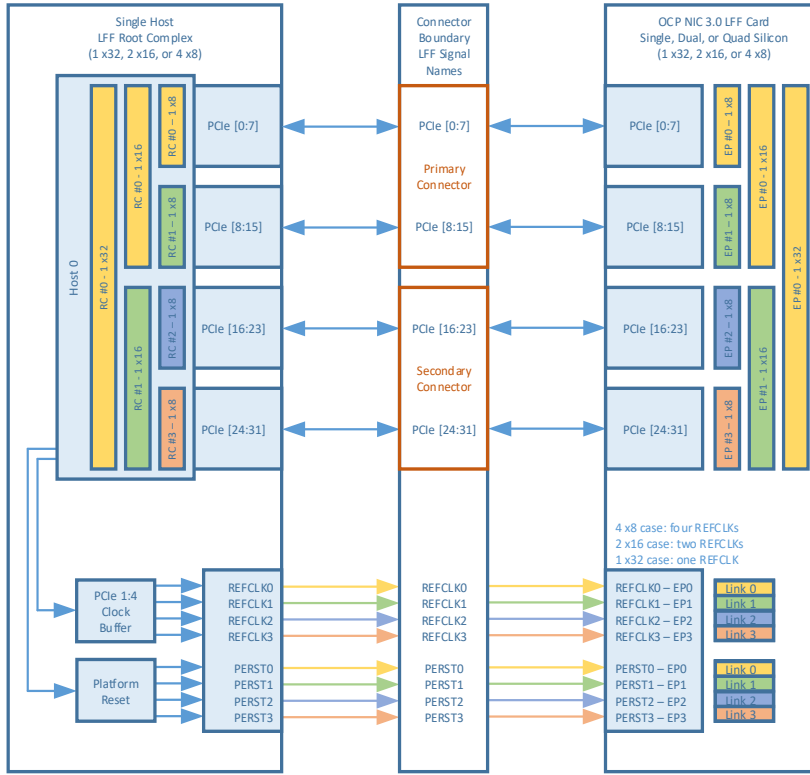
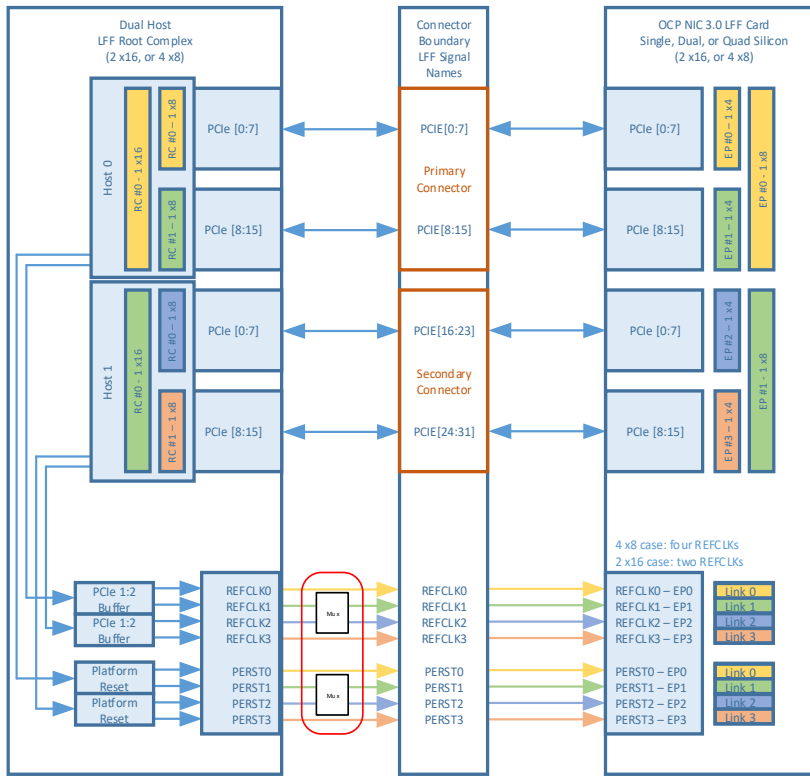
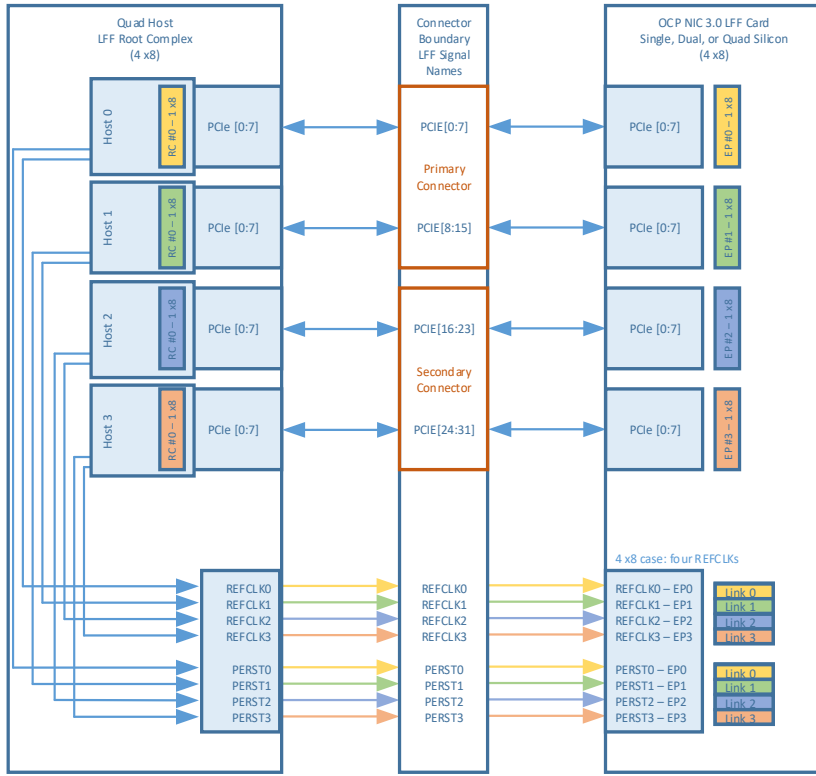

Figure 96: LFF PCIe REFCLK Mapping – Dual Host – 2 and 4 links



Note: For dual host applications that connect to a two link endpoint, the baseboard Host 1 REFCLK0 and PERST0 signal needs to be multiplexed to the REFCLK1 and PERST1 pins of the OCP NIC 3.0 card edge. This ensures the mandated Link n, REFCLKn and PERSTn mappings are maintained.

Figure 97: LFF PCIe REFCLK Mapping – Quad Host – 4 Links



Note: For quad host applications that connect to a two link endpoint, the baseboard Host 2 REFCLK and PERST signal needs to be multiplexed to the REFCLK1 and PERST1 pins of the OCP NIC 3.0 card edge. This ensures the mandated Link n, REFCLKn and PERSTn mappings are maintained.

Figure 90: PCIe Interface Connections for 1 x16 and 2 x8 OCP NIC 3.0 Cards

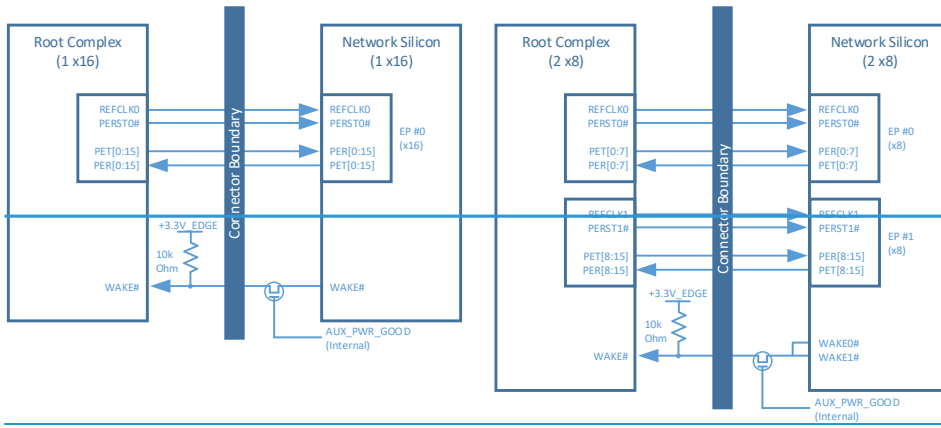
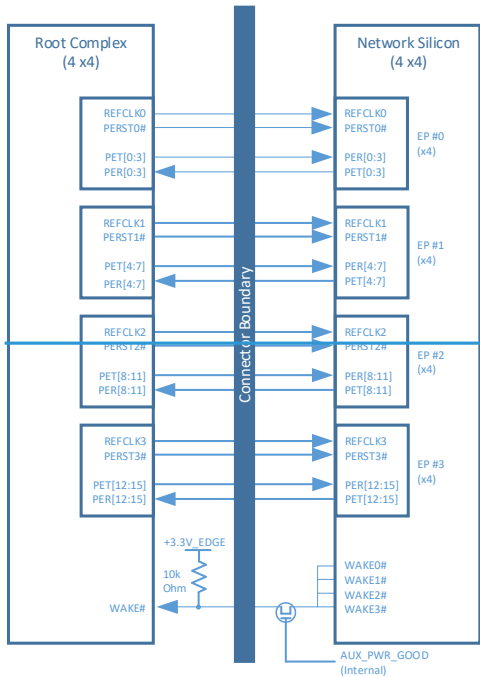

Figure 91: PCIe Interface Connections for a 4 x4 OCP NIC 3.0 Card



3.6.13.6.3 PCIe Bifurcation Results and REFCLK and PERST# Mapping Mapping Expansion

For the cases where the baseboard and OCP NIC 3.0 card bifurcation are permissible on the baseboard and OCP NIC 3.0 card, an expanded PCIe Bifurcation spreadsheet is available on the OCP Wiki site: <https://www.opencompute.org/wiki/Server/Mezz>.

Implementers shall use the spreadsheet version that is aligned with the spec. At the time of this writing, the latest spreadsheet is version 0.84.

The spreadsheet in this section enumerates all of the supported PCIe link, lane and REFCLK mappings for each supported configuration. The bifurcation decoder is shown in Section 3.5.3.

Commented [NT5]: I deleted the bifurcation expanded table screenshots from the spec. The spreadsheet tables are LARGE in cell count and are hard to read in the PDF. Text updated to point users to the bifurcation expanded tables in the OCP spreadsheet.

Table 33: Bifurcation for Single Host, Single Socket and Single Upstream Link (BIF[2:0]#=0b000)

Single Host, Single Upstream Socket, One Upstream Link, no bifurcation										Key: Cells shown as Link/Lane (e.g. Lx0/Ln0); HD = Host Disabled Lane															
Card Width	Card Name	Supported Modes	Bifurcation	Host	Upstream Devices	Upstream Links	BF (2.0#)	Re-using Link	Ln0	Ln1	Ln2	Ln3	Ln4	Ln5	Ln6	Ln7	Ln8	Ln9	Ln10	Ln11	Ln12	Ln13	Ln14	Ln15	
n/a	Not Present	Card Not Present	FRSNTES3.0#	1Host	1Upstream Socket	1Link	0x000	-	Lx0, Ln0	Lx0, Ln1	Lx0, Ln2	Lx0, Ln3	Lx0, Ln4	Lx0, Ln5	Lx0, Ln6	Lx0, Ln7									
2C	1x8 Option A	1x8, 1x4, 1x2, 1x1	0x110	1Host	1Upstream Socket	1Link	0x000	1x8	Lx0, Ln0	Lx0, Ln1	Lx0, Ln2	Lx0, Ln3	Lx0, Ln4	Lx0, Ln5	Lx0, Ln6	Lx0, Ln7									
2C	1x4	1x4, 1x2, 1x1	0x110	1Host	1Upstream Socket	1Link	0x000	1x2	Lx0, Ln0	Lx0, Ln1	Lx0, Ln2	Lx0, Ln3													
2C	1x2	1x2, 1x1	0x110	1Host	1Upstream Socket	1Link	0x000	1x1	Lx0, Ln0																
2C	1x1	1x1	0x110	1Host	1Upstream Socket	1Link	0x000	1x1	Lx0, Ln0																
2C	1x8 Option B	1x8, 1x4, 1x2, 1x1	0x101	1Host	1Upstream Socket	1Link	0x000	1x8	Lx0, Ln0	Lx0, Ln1	Lx0, Ln2	Lx0, Ln3	Lx0, Ln4	Lx0, Ln5	Lx0, Ln6	Lx0, Ln7	HD	HD	HD	HD	HD	HD	HD	HD	HD
4C	2x8 Option B	2x8, 2x4, 2x2, 2x1	0x101	1Host	1Upstream Socket	1Link	0x000	1x8	Lx0, Ln0	Lx0, Ln1	Lx0, Ln2	Lx0, Ln3	Lx0, Ln4	Lx0, Ln5	Lx0, Ln6	Lx0, Ln7	HD	HD	HD	HD	HD	HD	HD	HD	HD
4C	2x8 Option C	2x8, 1x4, 4x4, 4x2, 4x1	0x100	1Host	1Upstream Socket	1Link	0x000	1x8	Lx0, Ln0	Lx0, Ln1	Lx0, Ln2	Lx0, Ln3	Lx0, Ln4	Lx0, Ln5	Lx0, Ln6	Lx0, Ln7									
2C	1x8 Option D	2x4, 4x4, 4x2, 4x1	0x100	1Host	1Upstream Socket	1Link	0x000	1x8	Lx0, Ln0	Lx0, Ln1	Lx0, Ln2	Lx0, Ln3	Lx0, Ln4	Lx0, Ln5	Lx0, Ln6	Lx0, Ln7	HD	HD	HD	HD	HD	HD	HD	HD	HD
RSVD	RSVD	RSVD	0x101	1Host	1Upstream Socket	1Link	0x000	-	Lx0, Ln0	Lx0, Ln1	Lx0, Ln2	Lx0, Ln3													
2C	2x4	2x4, 2x2, 2x1	0x101	1Host	1Upstream Socket	1Link	0x000	1x2	Lx0, Ln0	Lx0, Ln1	Lx0, Ln2	Lx0, Ln3													
2C	4x2	2x2, 2x1	0x101	1Host	1Upstream Socket	1Link	0x000	1x2	Lx0, Ln0	Lx0, Ln1	Lx0, Ln2	Lx0, Ln3													
RSVD	RSVD	RSVD	0x100	1Host	1Upstream Socket	1Link	0x000	-	Lx0, Ln0	Lx0, Ln1	Lx0, Ln2	Lx0, Ln3													
4C	1x8 Option A	1x8, 1x4, 1x2, 1x1	0x011	1Host	1Upstream Socket	1Link	0x000	1x8	Lx0, Ln0	Lx0, Ln1	Lx0, Ln2	Lx0, Ln3	Lx0, Ln4	Lx0, Ln5	Lx0, Ln6	Lx0, Ln7	Lx0, Ln8	Lx0, Ln9	Lx0, Ln10	Lx0, Ln11	Lx0, Ln12	Lx0, Ln13	Lx0, Ln14	Lx0, Ln15	
4C	2x8 Option A	2x8, 2x4, 2x2, 2x1	0x010	1Host	1Upstream Socket	1Link	0x000	1x8	Lx0, Ln0	Lx0, Ln1	Lx0, Ln2	Lx0, Ln3	Lx0, Ln4	Lx0, Ln5	Lx0, Ln6	Lx0, Ln7	Lx0, Ln8	Lx0, Ln9	Lx0, Ln10	Lx0, Ln11	Lx0, Ln12	Lx0, Ln13	Lx0, Ln14	Lx0, Ln15	
4C	1x8 Option B	1x8, 1x4, 1x2, 1x1	0x001	1Host	1Upstream Socket	1Link	0x000	1x8	Lx0, Ln0	Lx0, Ln1	Lx0, Ln2	Lx0, Ln3	Lx0, Ln4	Lx0, Ln5	Lx0, Ln6	Lx0, Ln7	HD	HD	HD	HD	HD	HD	HD	HD	HD
4C	1x8 Option C	2x8, 2x4, 2x2, 2x1	0x000	1Host	1Upstream Socket	1Link	0x000	1x8	Lx0, Ln0	Lx0, Ln1	Lx0, Ln2	Lx0, Ln3	Lx0, Ln4	Lx0, Ln5	Lx0, Ln6	Lx0, Ln7	HD	HD	HD	HD	HD	HD	HD	HD	HD
4C	1x8 Option D	4x4, 4x2, 4x1	0x001	1Host	1Upstream Socket	1Link	0x000	1x4	Lx0, Ln0	Lx0, Ln1	Lx0, Ln2	Lx0, Ln3	HD	HD	HD	HD	HD	HD	HD	HD	HD	HD	HD	HD	HD
RSVD	RSVD	RSVD	0x000	1Host	1Upstream Socket	1Link	0x000	-	Lx0, Ln0	Lx0, Ln1	Lx0, Ln2	Lx0, Ln3													
RSVD	RSVD	RSVD	0x000	1Host	1Upstream Socket	1Link	0x000	-	Lx0, Ln0	Lx0, Ln1	Lx0, Ln2	Lx0, Ln3													

Table 34: Bifurcation for Single Host, Single Socket and Single/Dual Upstream Links (BIF[2:0]#-0b000)

Single Host, Single Upstream Socket, One or Two Upstream Links	Card Width	Card Short Name	Supported Bifurcation Modes	Card Encoding FFSM(B[3:0])#	Host	Upstream Devices For 2 Links	BIF [2:0]#	Resulting Link	Ln 0	Ln 1	Ln 2	Ln 3	Ln 4	Ln 5	Ln 6	Ln 7	Ln 8	Ln 9	Ln 10	Ln 11	Ln 12	Ln 13	Ln 14	Ln 15
1x8, 1x8, 1x4, 1x2, 1x1 2x8, 2x4, 2x2, 2x1	1x8	Option A	Card Not Present	0b1111	1Host	1Upstream Socket For 2 Links	0b0000	1x8	Lk0	Lk0	Lk0	Lk0	Lk0	Lk0	Lk0									
	2x8	Option A	1x4, 1x2, 1x1	0b1110	1Host	1Upstream Socket For 2 Links	0b0000	1x4	Lk0	Lk0	Lk0	Lk0	Lk0	Lk0	Lk0	Lk0								
	2x4	Option A	1x2, 1x1	0b1110	1Host	1Upstream Socket For 2 Links	0b0000	1x2	Lk0	Lk0	Lk0	Lk0	Lk0	Lk0	Lk0	Lk0								
	1x1	Option A	1x1	0b1110	1Host	1Upstream Socket For 2 Links	0b0000	1x1	Lk0	Lk0	Lk0	Lk0	Lk0	Lk0	Lk0	Lk0								
	1x8	Option B	2x8, 2x4, 2x1	0b1101	1Host	1Upstream Socket For 2 Links	0b0000	1x8	Lk0	Lk0	Lk0	Lk0	Lk0	Lk0	Lk0	Lk0	Lk0	HD	HD	HD	HD	HD	HD	HD
	2x8	Option B	4x4, 4x2, 4x1	0b1101	1Host	1Upstream Socket For 2 Links	0b0000	2x8	Lk0	Lk0	Lk0	Lk0	Lk0	Lk0	Lk0	Lk0	Lk0	Lk0	Lk0	Lk0	Lk0	Lk0	Lk0	Lk0
	2x4	Option C	2x4	0b1100	1Host	1Upstream Socket For 2 Links	0b0000	1x8	Lk0	Lk0	Lk0	Lk0	Lk0	Lk0	Lk0	Lk0	Lk0							
	1x8	Option D	4x2 (Furr 8 lanes), 4x1	0b1000	1Host	1Upstream Socket For 2 Links	0b0000	1x8	Lk0	Lk0	Lk0	Lk0	Lk0	Lk0	Lk0	Lk0	Lk0	Lk0	Lk0	Lk0	Lk0	Lk0	Lk0	Lk0
	1x8	Option D	2x8, 2x4, 2x2 (Furr 8 lanes), 4x1	0b1010	1Host	1Upstream Socket For 2 Links	0b0000	-	Lk0	Lk0	Lk0	Lk0	Lk0	Lk0	Lk0	Lk0	Lk0	Lk0	Lk0	Lk0	Lk0	Lk0	Lk0	Lk0
	2x4	Option D	2x4, 2x2, 2x1	0b1010	1Host	1Upstream Socket For 2 Links	0b0000	1x4	Lk0	Lk0	Lk0	Lk0	Lk0	Lk0	Lk0	Lk0	Lk0	Lk0	Lk0	Lk0	Lk0	Lk0	Lk0	Lk0
	1x4	Option D	1x4, 1x2, 1x1	0b1001	1Host	1Upstream Socket For 2 Links	0b0000	1x2	Lk0	Lk0	Lk0	Lk0	Lk0	Lk0	Lk0	Lk0	Lk0	Lk0	Lk0	Lk0	Lk0	Lk0	Lk0	Lk0
	4x2	Option D	2x2, 2x1	0b1001	1Host	1Upstream Socket For 2 Links	0b0000	-	Lk0	Lk0	Lk0	Lk0	Lk0	Lk0	Lk0	Lk0	Lk0	Lk0	Lk0	Lk0	Lk0	Lk0	Lk0	Lk0
	1x8	Option A	2x8, 1x8, 1x4, 1x2, 1x1	0b0111	1Host	1Upstream Socket For 2 Links	0b0000	1x8	Lk0	Lk0	Lk0	Lk0	Lk0	Lk0	Lk0	Lk0	Lk0	Lk0	Lk0	Lk0	Lk0	Lk0	Lk0	Lk0
	2x8	Option A	2x8, 2x4, 2x2, 2x1	0b0110	1Host	1Upstream Socket For 2 Links	0b0000	2x8	Lk0	Lk0	Lk0	Lk0	Lk0	Lk0	Lk0	Lk0	Lk0	Lk0	Lk0	Lk0	Lk0	Lk0	Lk0	Lk0
	1x8	Option B	1x8, 1x4, 1x2, 1x1	0b0101	1Host	1Upstream Socket For 2 Links	0b0000	1x8	Lk0	Lk0	Lk0	Lk0	Lk0	Lk0	Lk0	Lk0	Lk0	Lk0	Lk0	Lk0	Lk0	Lk0	Lk0	Lk0
	2x8	Option B	2x8, 2x4, 2x2, 2x1	0b0100	1Host	1Upstream Socket For 2 Links	0b0000	1x8	Lk0	Lk0	Lk0	Lk0	Lk0	Lk0	Lk0	Lk0	Lk0	Lk0	Lk0	Lk0	Lk0	Lk0	Lk0	Lk0
	1x8	Option C	4x4, 4x2, 4x1	0b0011	1Host	1Upstream Socket For 2 Links	0b0000	2x4	Lk0	Lk0	Lk0	Lk0	Lk0	Lk0	Lk0	Lk0	Lk0	Lk0	Lk0	Lk0	Lk0	Lk0	Lk0	Lk0
	RSVD	Option C	RSVD	0b0010	1Host	1Upstream Socket For 2 Links	0b0000	-	Lk0	Lk0	Lk0	Lk0	Lk0	Lk0	Lk0	Lk0	Lk0	Lk0	Lk0	Lk0	Lk0	Lk0	Lk0	Lk0
	RSVD	Option C	RSVD	0b0001	1Host	1Upstream Socket For 2 Links	0b0000	-	Lk0	Lk0	Lk0	Lk0	Lk0	Lk0	Lk0	Lk0	Lk0	Lk0	Lk0	Lk0	Lk0	Lk0	Lk0	Lk0
	RSVD	Option C	RSVD	0b0000	1Host	1Upstream Socket For 2 Links	0b0000	-	Lk0	Lk0	Lk0	Lk0	Lk0	Lk0	Lk0	Lk0	Lk0	Lk0	Lk0	Lk0	Lk0	Lk0	Lk0	Lk0

Key: Cells shown as Lnk#Ln# (e.g. Lk0Ln0); HD=Host Disabled Lane

Table 35: Bifurcation for Single Host, Single Socket and Single/Dual/Quad Upstream Links
(BIF[2:0]#-0b000)

Min Card Width		Supported Bifurcation Modes	Host	Upstream Devices	BIF	Key: Cells shown as Ln1, Lane 6, e.g. LK0, Ln0, HD = Host Disabled Lane																
1x8, 1x4, 1x2, 1x1 2x4, 2x2, 2x1 4x4, 4x2, 4x1	Add-in-Card Encoding PSM[B3:0]#					Host	Upstream Devices	Upstream Links	Ln0	Ln1	Ln2	Ln3	Ln4	Ln5	Ln6	Ln7	Ln8	Ln9	Ln10	Ln11	Ln12	Ln13
2C	1x8 Option A	1x8, 1x4, 1x2, 1x1	Host	1 Upstream Socket	0x0000		Lk0	Lk0	Lk0	Lk0	Lk0	Lk0	Lk0									
2C	1x4	1x4, 1x2, 1x1	Host	1 Upstream Socket	0x110		Lk0	Lk0	Lk0	Lk0	Lk0	Lk0	Lk0									
2C	1x2	1x2, 1x1	Host	1 Upstream Socket	0x110		Lk0	Lk0	Lk0	Lk0	Lk0	Lk0	Lk0									
2C	1x1	1x1	Host	1 Upstream Socket	0x110		Lk0	Lk0	Lk0	Lk0	Lk0	Lk0	Lk0									
2C	1x8 Option B	2x4, 2x2, 2x1	Host	1 Upstream Socket	0x101		Lk0	Lk0	Lk0	Lk0	Lk0	Lk0	Lk0	HD	HD	HD	HD	HD	HD	HD	HD	HD
4C	2x8 Option B	2x8, 2x4, 2x2, 2x1	Host	1 Upstream Socket	0x101		Lk0	Lk0	Lk0	Lk0	Lk0	Lk0	Lk0	Lk0	Lk0	Lk0	Lk0	Lk0	Lk0	Lk0	Lk0	Lk0
2C	1x8 Option D	4x2 (Frac 8 lanes), 4x1	Host	1 Upstream Socket	0x100		Lk0	Lk0	Lk0	Lk0	Lk0	Lk0	Lk0									
4C	1x8 Option D	4x2 (Frac 8 lanes), 4x1	Host	1 Upstream Socket	0x100		Lk0	Lk0	Lk0	Lk0	Lk0	Lk0	Lk0									
RSVD	RSVD	RSVD	Host	1 Upstream Socket	0x010		Lk0	Lk0	Lk0	Lk0	Lk0	Lk0	Lk0									
2C	2x4	1x4, 1x2, 1x1	Host	1 Upstream Socket	0x001		Lk0	Lk0	Lk0	Lk0	Lk0	Lk0	Lk0									
2C	4x2	2x2, 2x1	Host	1 Upstream Socket	0x001		Lk0	Lk0	Lk0	Lk0	Lk0	Lk0	Lk0									
RSVD	RSVD	RSVD or future 8 encoding	Host	1 Upstream Socket	0x000		Lk0	Lk0	Lk0	Lk0	Lk0	Lk0	Lk0									
4C	1x8 Option A	2x8, 2x4, 2x2, 2x1	Host	1 Upstream Socket	0x011		Lk0	Lk0	Lk0	Lk0	Lk0	Lk0	Lk0	Lk0	Lk0	Lk0	Lk0	Lk0	Lk0	Lk0	Lk0	Lk0
4C	2x8 Option A	1x8, 1x4, 1x2, 2x1	Host	1 Upstream Socket	0x010		Lk0	Lk0	Lk0	Lk0	Lk0	Lk0	Lk0	Lk0	Lk0	Lk0	Lk0	Lk0	Lk0	Lk0	Lk0	Lk0
4C	1x8 Option B	2x8, 2x4, 2x2, 2x1	Host	1 Upstream Socket	0x001		Lk0	Lk0	Lk0	Lk0	Lk0	Lk0	Lk0	Lk0	Lk0	Lk0	Lk0	Lk0	Lk0	Lk0	Lk0	Lk0
4C	1x8 Option C	2x8, 2x4, 2x2, 2x1	Host	1 Upstream Socket	0x010		Lk0	Lk0	Lk0	Lk0	Lk0	Lk0	Lk0	Lk0	Lk0	Lk0	Lk0	Lk0	Lk0	Lk0	Lk0	Lk0
4C	1x8 Option C	4x4, 4x2, 4x1	Host	1 Upstream Socket	0x011		Lk0	Lk0	Lk0	Lk0	Lk0	Lk0	Lk0	Lk0	Lk0	Lk0	Lk0	Lk0	Lk0	Lk0	Lk0	Lk0
RSVD	RSVD	RSVD	Host	1 Upstream Socket	0x010		Lk0	Lk0	Lk0	Lk0	Lk0	Lk0	Lk0	Lk0	Lk0	Lk0	Lk0	Lk0	Lk0	Lk0	Lk0	Lk0
RSVD	RSVD	RSVD	Host	1 Upstream Socket	0x001		Lk0	Lk0	Lk0	Lk0	Lk0	Lk0	Lk0	Lk0	Lk0	Lk0	Lk0	Lk0	Lk0	Lk0	Lk0	Lk0
RSVD	RSVD	RSVD	Host	1 Upstream Socket	0x000		Lk0	Lk0	Lk0	Lk0	Lk0	Lk0	Lk0	Lk0	Lk0	Lk0	Lk0	Lk0	Lk0	Lk0	Lk0	Lk0

Table 36: Bifurcation for Single Host, Dual Sockets and Dual Upstream Links (BIF[2:0]#=0b001)

Single Host: Two Upstream Sockets, Two Upstream Links	AF14 In-Card Encoding		Host	Upstream Devices	Upstream Links	BIF [2:0]#	Re-bundling Link	Key: Cells shown as Link/Lane (e.g. L10/L10:HD) - Host Disabled, Lane														
	Card Width	Card Short Name						Supported Bifurcation Modes	Ln 0	Ln 1	Ln 2	Ln 3	Ln 4	Ln 5	Ln 6	Ln 7	Ln 8	Ln 9	Ln 10	Ln 11	Ln 12	Ln 13
2C	1x8	Option A	1x8, 1x4, 1x2, 1x1	2 Upstream Sockets	2 Links	0b110	-	Lk0, Ln0	Lk0, Ln0	Lk0, Ln0	Lk0, Ln0	Lk0, Ln0	Lk0, Ln0	Lk0, Ln0	Lk0, Ln0	Lk0, Ln0	Lk0, Ln0	Lk0, Ln0	Lk0, Ln0	Lk0, Ln0	Lk0, Ln0	
2C	1x8	Option A	1x8, 1x4, 1x2, 1x1	2 Upstream Sockets	2 Links	0b110	(Socket 0 only)	Lk0, Ln0	Lk0, Ln0	Lk0, Ln0	Lk0, Ln0	Lk0, Ln0	Lk0, Ln0	Lk0, Ln0	Lk0, Ln0	Lk0, Ln0	Lk0, Ln0	Lk0, Ln0	Lk0, Ln0	Lk0, Ln0	Lk0, Ln0	
2C	1x4		1x4, 1x2, 1x1	2 Upstream Sockets	2 Links	0b001	(Socket 0 only)	Lk0, Ln0	Lk0, Ln0	Lk0, Ln0	Lk0, Ln0	Lk0, Ln0	Lk0, Ln0	Lk0, Ln0	Lk0, Ln0	Lk0, Ln0	Lk0, Ln0	Lk0, Ln0	Lk0, Ln0	Lk0, Ln0	Lk0, Ln0	
2C	1x2		1x2, 1x1	2 Upstream Sockets	2 Links	0b001	(Socket 0 only)	Lk0, Ln0	Lk0, Ln0	Lk0, Ln0	Lk0, Ln0	Lk0, Ln0	Lk0, Ln0	Lk0, Ln0	Lk0, Ln0	Lk0, Ln0	Lk0, Ln0	Lk0, Ln0	Lk0, Ln0	Lk0, Ln0	Lk0, Ln0	
2C	1x1		1x1	2 Upstream Sockets	2 Links	0b001	(Socket 0 only)	Lk0, Ln0	Lk0, Ln0	Lk0, Ln0	Lk0, Ln0	Lk0, Ln0	Lk0, Ln0	Lk0, Ln0	Lk0, Ln0	Lk0, Ln0	Lk0, Ln0	Lk0, Ln0	Lk0, Ln0	Lk0, Ln0	Lk0, Ln0	
2C	1x8	Option B	1x8, 1x4, 1x2, 1x1	2 Upstream Sockets	2 Links	0b101	1x8	Lk0, Ln0	Lk0, Ln0	Lk0, Ln0	Lk0, Ln0	Lk0, Ln0	Lk0, Ln0	Lk0, Ln0	Lk0, Ln0	Lk0, Ln0	Lk0, Ln0	Lk0, Ln0	Lk0, Ln0	Lk0, Ln0	Lk0, Ln0	
2C	2x8	Option B	2x8, 2x4, 2x1	2 Upstream Sockets	2 Links	0b001	(Socket 0 only)	Lk0, Ln0	Lk0, Ln0	Lk0, Ln0	Lk0, Ln0	Lk0, Ln0	Lk0, Ln0	Lk0, Ln0	Lk0, Ln0	Lk0, Ln0	Lk0, Ln0	Lk0, Ln0	Lk0, Ln0	Lk0, Ln0	Lk0, Ln0	
4C	2x8	Option B	4x4, 4x2, 4x1	2 Upstream Sockets	2 Links	0b001	2x8	Lk0, Ln0	Lk0, Ln0	Lk0, Ln0	Lk0, Ln0	Lk0, Ln0	Lk0, Ln0	Lk0, Ln0	Lk0, Ln0	Lk0, Ln0	Lk0, Ln0	Lk0, Ln0	Lk0, Ln0	Lk0, Ln0	Lk0, Ln0	
2C	1x8	Option D	1x8, 1x4, 1x2	2 Upstream Sockets	2 Links	0b100	2x8	Lk0, Ln0	Lk0, Ln0	Lk0, Ln0	Lk0, Ln0	Lk0, Ln0	Lk0, Ln0	Lk0, Ln0	Lk0, Ln0	Lk0, Ln0	Lk0, Ln0	Lk0, Ln0	Lk0, Ln0	Lk0, Ln0	Lk0, Ln0	
2C	1x8	Option D	1x8, 1x4, 1x2	2 Upstream Sockets	2 Links	0b001	(Socket 0 only)	Lk0, Ln0	Lk0, Ln0	Lk0, Ln0	Lk0, Ln0	Lk0, Ln0	Lk0, Ln0	Lk0, Ln0	Lk0, Ln0	Lk0, Ln0	Lk0, Ln0	Lk0, Ln0	Lk0, Ln0	Lk0, Ln0	Lk0, Ln0	
4C	1x8	Option D	1x8, 1x4, 1x2	2 Upstream Sockets	2 Links	0b100	2x8	Lk0, Ln0	Lk0, Ln0	Lk0, Ln0	Lk0, Ln0	Lk0, Ln0	Lk0, Ln0	Lk0, Ln0	Lk0, Ln0	Lk0, Ln0	Lk0, Ln0	Lk0, Ln0	Lk0, Ln0	Lk0, Ln0	Lk0, Ln0	
RSVD	RSVD	RSVD	RSVD	2 Upstream Sockets	2 Links	0b001	-	Lk0, Ln0	Lk0, Ln0	Lk0, Ln0	Lk0, Ln0	Lk0, Ln0	Lk0, Ln0	Lk0, Ln0	Lk0, Ln0	Lk0, Ln0	Lk0, Ln0	Lk0, Ln0	Lk0, Ln0	Lk0, Ln0	Lk0, Ln0	
2C	2x4		2x4, 2x2, 2x1	2 Upstream Sockets	2 Links	0b010	1x4	Lk0, Ln0	Lk0, Ln0	Lk0, Ln0	Lk0, Ln0	Lk0, Ln0	Lk0, Ln0	Lk0, Ln0	Lk0, Ln0	Lk0, Ln0	Lk0, Ln0	Lk0, Ln0	Lk0, Ln0	Lk0, Ln0	Lk0, Ln0	
2C	1x4		1x4, 1x2, 1x1	2 Upstream Sockets	2 Links	0b001	(Socket 0 only)	Lk0, Ln0	Lk0, Ln0	Lk0, Ln0	Lk0, Ln0	Lk0, Ln0	Lk0, Ln0	Lk0, Ln0	Lk0, Ln0	Lk0, Ln0	Lk0, Ln0	Lk0, Ln0	Lk0, Ln0	Lk0, Ln0	Lk0, Ln0	
2C	2x2		2x2, 2x1	2 Upstream Sockets	2 Links	0b001	1x2	Lk0, Ln0	Lk0, Ln0	Lk0, Ln0	Lk0, Ln0	Lk0, Ln0	Lk0, Ln0	Lk0, Ln0	Lk0, Ln0	Lk0, Ln0	Lk0, Ln0	Lk0, Ln0	Lk0, Ln0	Lk0, Ln0	Lk0, Ln0	
RSVD	RSVD	RSVD	RSVD	2 Upstream Sockets	2 Links	0b100	-	Lk0, Ln0	Lk0, Ln0	Lk0, Ln0	Lk0, Ln0	Lk0, Ln0	Lk0, Ln0	Lk0, Ln0	Lk0, Ln0	Lk0, Ln0	Lk0, Ln0	Lk0, Ln0	Lk0, Ln0	Lk0, Ln0	Lk0, Ln0	
4C	1x16	Option A	1x16, 1x8, 1x4, 1x2, 1x1	2 Upstream Sockets	2 Links	0b011	1x8	Lk0, Ln0	Lk0, Ln0	Lk0, Ln0	Lk0, Ln0	Lk0, Ln0	Lk0, Ln0	Lk0, Ln0	Lk0, Ln0	Lk0, Ln0	Lk0, Ln0	Lk0, Ln0	Lk0, Ln0	Lk0, Ln0	Lk0, Ln0	
4C	2x8	Option A	2x8, 2x4, 2x2, 2x1	2 Upstream Sockets	2 Links	0b010	2x8	Lk0, Ln0	Lk0, Ln0	Lk0, Ln0	Lk0, Ln0	Lk0, Ln0	Lk0, Ln0	Lk0, Ln0	Lk0, Ln0	Lk0, Ln0	Lk0, Ln0	Lk0, Ln0	Lk0, Ln0	Lk0, Ln0	Lk0, Ln0	
4C	1x16	Option B	1x16, 1x8, 1x4, 1x2, 1x1	2 Upstream Sockets	2 Links	0b011	2x8	Lk0, Ln0	Lk0, Ln0	Lk0, Ln0	Lk0, Ln0	Lk0, Ln0	Lk0, Ln0	Lk0, Ln0	Lk0, Ln0	Lk0, Ln0	Lk0, Ln0	Lk0, Ln0	Lk0, Ln0	Lk0, Ln0	Lk0, Ln0	
4C	1x16	Option B	1x16, 1x8, 1x4, 1x2, 1x1	2 Upstream Sockets	2 Links	0b010	2x8	Lk0, Ln0	Lk0, Ln0	Lk0, Ln0	Lk0, Ln0	Lk0, Ln0	Lk0, Ln0	Lk0, Ln0	Lk0, Ln0	Lk0, Ln0	Lk0, Ln0	Lk0, Ln0	Lk0, Ln0	Lk0, Ln0	Lk0, Ln0	
4C	1x16	Option C	4x4, 4x2, 4x1	2 Upstream Sockets	2 Links	0b010	2x8	Lk0, Ln0	Lk0, Ln0	Lk0, Ln0	Lk0, Ln0	Lk0, Ln0	Lk0, Ln0	Lk0, Ln0	Lk0, Ln0	Lk0, Ln0	Lk0, Ln0	Lk0, Ln0	Lk0, Ln0	Lk0, Ln0	Lk0, Ln0	
4C	4x4		4x4, 4x2, 4x1	2 Upstream Sockets	2 Links	0b001	2x4	Lk0, Ln0	Lk0, Ln0	Lk0, Ln0	Lk0, Ln0	Lk0, Ln0	Lk0, Ln0	Lk0, Ln0	Lk0, Ln0	Lk0, Ln0	Lk0, Ln0	Lk0, Ln0	Lk0, Ln0	Lk0, Ln0	Lk0, Ln0	
RSVD	RSVD	RSVD	RSVD	2 Upstream Sockets	2 Links	0b001	(EF 0 and 2 only)	Lk0, Ln0	Lk0, Ln0	Lk0, Ln0	Lk0, Ln0	Lk0, Ln0	Lk0, Ln0	Lk0, Ln0	Lk0, Ln0	Lk0, Ln0	Lk0, Ln0	Lk0, Ln0	Lk0, Ln0	Lk0, Ln0	Lk0, Ln0	
RSVD	RSVD	RSVD	RSVD	2 Upstream Sockets	2 Links	0b001	-	Lk0, Ln0	Lk0, Ln0	Lk0, Ln0	Lk0, Ln0	Lk0, Ln0	Lk0, Ln0	Lk0, Ln0	Lk0, Ln0	Lk0, Ln0	Lk0, Ln0	Lk0, Ln0	Lk0, Ln0	Lk0, Ln0	Lk0, Ln0	
RSVD	RSVD	RSVD	RSVD	2 Upstream Sockets	2 Links	0b001	-	Lk0, Ln0	Lk0, Ln0	Lk0, Ln0	Lk0, Ln0	Lk0, Ln0	Lk0, Ln0	Lk0, Ln0	Lk0, Ln0	Lk0, Ln0	Lk0, Ln0	Lk0, Ln0	Lk0, Ln0	Lk0, Ln0	Lk0, Ln0	
RSVD	RSVD	RSVD	RSVD	2 Upstream Sockets	2 Links	0b001	-	Lk0, Ln0	Lk0, Ln0	Lk0, Ln0	Lk0, Ln0	Lk0, Ln0	Lk0, Ln0	Lk0, Ln0	Lk0, Ln0	Lk0, Ln0	Lk0, Ln0	Lk0, Ln0	Lk0, Ln0	Lk0, Ln0	Lk0, Ln0	

Table 37: Bifurcation for Single Host, Quad Sockets and Quad Upstream Links (BIF[2:0]#=0b010)

Single Host, Four Upstream Sockets, Four Upstream Links	4 x4, 4x2, 4x1				Key: Cells shown as Link/Lane (e.g. Lk0/Ln0), HD = Host Disabled, Line																		
Card Width	Card Name	Supported Modes	Host	Upstream Devices	Upstream Links	BIF [2:0]#	Re-bundling Link	Ln0	Ln1	Ln2	Ln3	Ln4	Ln5	Ln6	Ln7	Ln8	Ln9	Ln10	Ln11	Ln12	Ln13	Ln14	Ln15
1x4	Not Present	Card Not Present	1Host	4 Upstream Sockets	4 Links	0b010	-	Lk0, Ln0	Lk0, Ln0	Lk0, Ln0	Lk0, Ln0	Lk0, Ln0	Lk0, Ln0	Lk0, Ln0	Lk0, Ln0	Lk0, Ln0	Lk0, Ln0	Lk0, Ln0	Lk0, Ln0	Lk0, Ln0	Lk0, Ln0	Lk0, Ln0	Lk0, Ln0
2C	1x8 Option A	1x8, 1x4, 1x2, 1x1	1Host	4 Upstream Sockets	4 Links	0b110	1x4 (Socket 0 only)	Lk0, Ln0	Lk0, Ln0	Lk0, Ln0	Lk0, Ln0	Lk0, Ln0	Lk0, Ln0	Lk0, Ln0	Lk0, Ln0	Lk0, Ln0	Lk0, Ln0	Lk0, Ln0	Lk0, Ln0	Lk0, Ln0	Lk0, Ln0	Lk0, Ln0	Lk0, Ln0
2C	1x4	1x4, 1x2, 1x1	1Host	4 Upstream Sockets	4 Links	0b110	1x4 (Socket 0 only)	Lk0, Ln0	Lk0, Ln0	Lk0, Ln0	Lk0, Ln0	Lk0, Ln0	Lk0, Ln0	Lk0, Ln0	Lk0, Ln0	Lk0, Ln0	Lk0, Ln0	Lk0, Ln0	Lk0, Ln0	Lk0, Ln0	Lk0, Ln0	Lk0, Ln0	Lk0, Ln0
2C	1x2	1x2, 1x1	1Host	4 Upstream Sockets	4 Links	0b010	1x2 (Socket 0 only)	Lk0, Ln0	Lk0, Ln0	Lk0, Ln0	Lk0, Ln0	Lk0, Ln0	Lk0, Ln0	Lk0, Ln0	Lk0, Ln0	Lk0, Ln0	Lk0, Ln0	Lk0, Ln0	Lk0, Ln0	Lk0, Ln0	Lk0, Ln0	Lk0, Ln0	Lk0, Ln0
2C	1x1	1x1	1Host	4 Upstream Sockets	4 Links	0b010	1x1 (Socket 0 only)	Lk0, Ln0	Lk0, Ln0	Lk0, Ln0	Lk0, Ln0	Lk0, Ln0	Lk0, Ln0	Lk0, Ln0	Lk0, Ln0	Lk0, Ln0	Lk0, Ln0	Lk0, Ln0	Lk0, Ln0	Lk0, Ln0	Lk0, Ln0	Lk0, Ln0	Lk0, Ln0
2C	1x8 Option B	1x8, 1x4, 1x2, 1x1	1Host	4 Upstream Sockets	4 Links	0b101	2x4	Lk0, Ln0	Lk0, Ln0	Lk0, Ln0	Lk0, Ln0	Lk0, Ln0	Lk0, Ln0	Lk0, Ln0	Lk0, Ln0	Lk0, Ln0	Lk0, Ln0	Lk0, Ln0	Lk0, Ln0	Lk0, Ln0	Lk0, Ln0	Lk0, Ln0	Lk0, Ln0
4C	2x8 Option B	2x8, 2x4, 2x2, 2x1	1Host	4 Upstream Sockets	4 Links	0b101	4x4	Lk0, Ln0	Lk0, Ln0	Lk0, Ln0	Lk0, Ln0	Lk0, Ln0	Lk0, Ln0	Lk0, Ln0	Lk0, Ln0	Lk0, Ln0	Lk0, Ln0	Lk0, Ln0	Lk0, Ln0	Lk0, Ln0	Lk0, Ln0	Lk0, Ln0	Lk0, Ln0
4C	2x8 Option B	4x4, 4x2, 4x1	1Host	4 Upstream Sockets	4 Links	0b110	2x4	Lk0, Ln0	Lk0, Ln0	Lk0, Ln0	Lk0, Ln0	Lk0, Ln0	Lk0, Ln0	Lk0, Ln0	Lk0, Ln0	Lk0, Ln0	Lk0, Ln0	Lk0, Ln0	Lk0, Ln0	Lk0, Ln0	Lk0, Ln0	Lk0, Ln0	Lk0, Ln0
2C	1x8 Option D	4x2 (First 8 lanes), 4x1	1Host	4 Upstream Sockets	4 Links	0b110	4x4	Lk0, Ln0	Lk0, Ln0	Lk0, Ln0	Lk0, Ln0	Lk0, Ln0	Lk0, Ln0	Lk0, Ln0	Lk0, Ln0	Lk0, Ln0	Lk0, Ln0	Lk0, Ln0	Lk0, Ln0	Lk0, Ln0	Lk0, Ln0	Lk0, Ln0	Lk0, Ln0
4C	1x8 Option D	1x8, 1x4, 1x2, 1x1	1Host	4 Upstream Sockets	4 Links	0b101	2x4	Lk0, Ln0	Lk0, Ln0	Lk0, Ln0	Lk0, Ln0	Lk0, Ln0	Lk0, Ln0	Lk0, Ln0	Lk0, Ln0	Lk0, Ln0	Lk0, Ln0	Lk0, Ln0	Lk0, Ln0	Lk0, Ln0	Lk0, Ln0	Lk0, Ln0	Lk0, Ln0
RSVD	RSVD	RSVD	1Host	4 Upstream Sockets	4 Links	0b101	-	Lk0, Ln0	Lk0, Ln0	Lk0, Ln0	Lk0, Ln0	Lk0, Ln0	Lk0, Ln0	Lk0, Ln0	Lk0, Ln0	Lk0, Ln0	Lk0, Ln0	Lk0, Ln0	Lk0, Ln0	Lk0, Ln0	Lk0, Ln0	Lk0, Ln0	Lk0, Ln0
2C	2x4	2x4, 2x2, 2x1	1Host	4 Upstream Sockets	4 Links	0b010	2x2	Lk0, Ln0	Lk0, Ln0	Lk0, Ln0	Lk0, Ln0	Lk0, Ln0	Lk0, Ln0	Lk0, Ln0	Lk0, Ln0	Lk0, Ln0	Lk0, Ln0	Lk0, Ln0	Lk0, Ln0	Lk0, Ln0	Lk0, Ln0	Lk0, Ln0	Lk0, Ln0
2C	4x2	4x2 (First 8 lanes), 4x1	1Host	4 Upstream Sockets	4 Links	0b100	-	Lk0, Ln0	Lk0, Ln0	Lk0, Ln0	Lk0, Ln0	Lk0, Ln0	Lk0, Ln0	Lk0, Ln0	Lk0, Ln0	Lk0, Ln0	Lk0, Ln0	Lk0, Ln0	Lk0, Ln0	Lk0, Ln0	Lk0, Ln0	Lk0, Ln0	Lk0, Ln0
RSVD	RSVD	RSVD	1Host	4 Upstream Sockets	4 Links	0b011	1x4	Lk0, Ln0	Lk0, Ln0	Lk0, Ln0	Lk0, Ln0	Lk0, Ln0	Lk0, Ln0	Lk0, Ln0	Lk0, Ln0	Lk0, Ln0	Lk0, Ln0	Lk0, Ln0	Lk0, Ln0	Lk0, Ln0	Lk0, Ln0	Lk0, Ln0	Lk0, Ln0
4C	1x16 Option A	1x8, 1x4, 1x2, 1x1	1Host	4 Upstream Sockets	4 Links	0b011	2x4	Lk0, Ln0	Lk0, Ln0	Lk0, Ln0	Lk0, Ln0	Lk0, Ln0	Lk0, Ln0	Lk0, Ln0	Lk0, Ln0	Lk0, Ln0	Lk0, Ln0	Lk0, Ln0	Lk0, Ln0	Lk0, Ln0	Lk0, Ln0	Lk0, Ln0	Lk0, Ln0
4C	2x8 Option A	2x8, 2x4, 2x2, 2x1	1Host	4 Upstream Sockets	4 Links	0b010	2x4	Lk0, Ln0	Lk0, Ln0	Lk0, Ln0	Lk0, Ln0	Lk0, Ln0	Lk0, Ln0	Lk0, Ln0	Lk0, Ln0	Lk0, Ln0	Lk0, Ln0	Lk0, Ln0	Lk0, Ln0	Lk0, Ln0	Lk0, Ln0	Lk0, Ln0	Lk0, Ln0
4C	1x16 Option B	1x8, 1x4, 1x2, 1x1	1Host	4 Upstream Sockets	4 Links	0b011	2x4	Lk0, Ln0	Lk0, Ln0	Lk0, Ln0	Lk0, Ln0	Lk0, Ln0	Lk0, Ln0	Lk0, Ln0	Lk0, Ln0	Lk0, Ln0	Lk0, Ln0	Lk0, Ln0	Lk0, Ln0	Lk0, Ln0	Lk0, Ln0	Lk0, Ln0	Lk0, Ln0
4C	1x16 Option B	2x8, 2x4, 2x2, 2x1	1Host	4 Upstream Sockets	4 Links	0b010	2x4	Lk0, Ln0	Lk0, Ln0	Lk0, Ln0	Lk0, Ln0	Lk0, Ln0	Lk0, Ln0	Lk0, Ln0	Lk0, Ln0	Lk0, Ln0	Lk0, Ln0	Lk0, Ln0	Lk0, Ln0	Lk0, Ln0	Lk0, Ln0	Lk0, Ln0	Lk0, Ln0
4C	1x16 Option C	2x8, 2x4, 2x2, 2x1	1Host	4 Upstream Sockets	4 Links	0b010	4x4	Lk0, Ln0	Lk0, Ln0	Lk0, Ln0	Lk0, Ln0	Lk0, Ln0	Lk0, Ln0	Lk0, Ln0	Lk0, Ln0	Lk0, Ln0	Lk0, Ln0	Lk0, Ln0	Lk0, Ln0	Lk0, Ln0	Lk0, Ln0	Lk0, Ln0	Lk0, Ln0
4C	1x16 Option C	4x4, 4x2, 4x1	1Host	4 Upstream Sockets	4 Links	0b011	4x4	Lk0, Ln0	Lk0, Ln0	Lk0, Ln0	Lk0, Ln0	Lk0, Ln0	Lk0, Ln0	Lk0, Ln0	Lk0, Ln0	Lk0, Ln0	Lk0, Ln0	Lk0, Ln0	Lk0, Ln0	Lk0, Ln0	Lk0, Ln0	Lk0, Ln0	Lk0, Ln0
4C	4x4	4x4	1Host	4 Upstream Sockets	4 Links	0b011	4x4	Lk0, Ln0	Lk0, Ln0	Lk0, Ln0	Lk0, Ln0	Lk0, Ln0	Lk0, Ln0	Lk0, Ln0	Lk0, Ln0	Lk0, Ln0	Lk0, Ln0	Lk0, Ln0	Lk0, Ln0	Lk0, Ln0	Lk0, Ln0	Lk0, Ln0	Lk0, Ln0
RSVD	RSVD	RSVD	1Host	4 Upstream Sockets	4 Links	0b010	-	Lk0, Ln0	Lk0, Ln0	Lk0, Ln0	Lk0, Ln0	Lk0, Ln0	Lk0, Ln0	Lk0, Ln0	Lk0, Ln0	Lk0, Ln0	Lk0, Ln0	Lk0, Ln0	Lk0, Ln0	Lk0, Ln0	Lk0, Ln0	Lk0, Ln0	Lk0, Ln0
RSVD	RSVD	RSVD	1Host	4 Upstream Sockets	4 Links	0b010	-	Lk0, Ln0	Lk0, Ln0	Lk0, Ln0	Lk0, Ln0	Lk0, Ln0	Lk0, Ln0	Lk0, Ln0	Lk0, Ln0	Lk0, Ln0	Lk0, Ln0	Lk0, Ln0	Lk0, Ln0	Lk0, Ln0	Lk0, Ln0	Lk0, Ln0	Lk0, Ln0
RSVD	RSVD	RSVD	1Host	4 Upstream Sockets	4 Links	0b010	-	Lk0, Ln0	Lk0, Ln0	Lk0, Ln0	Lk0, Ln0	Lk0, Ln0	Lk0, Ln0	Lk0, Ln0	Lk0, Ln0	Lk0, Ln0	Lk0, Ln0	Lk0, Ln0	Lk0, Ln0	Lk0, Ln0	Lk0, Ln0	Lk0, Ln0	Lk0, Ln0

Table 38: Bifurcation for Single Host, Quad Sockets and Quad Upstream Links—First 8 PCIe Lanes
(BIF[2:0]#=0b011)

Min Card Width	Card Short Name	Supported Bifurcation Modes	Host	Add-in-Card Encoding PSX01ES3.0#	Upstream Devices	Upstream Links	BIF [2:0]#	Re-uting Link	Key: Cells shown as Ln0, Ln1, Ln2, Ln3, Ln4, Ln5, Ln6, Ln7, Ln8, Ln9, Ln10, Ln11, Ln12, Ln13, Ln14, Ln15															
									Ln0	Ln1	Ln2	Ln3	Ln4	Ln5	Ln6	Ln7	Ln8	Ln9	Ln10	Ln11	Ln12	Ln13	Ln14	Ln15
2C	1x8 Option A	1x8, 1x4, 1x2, 1x1	1Host	0b1110	4 Upstream Sockets	4Links	0b011	1x2	Ln0	Ln0														
2C	1x4	1x4, 1x2, 1x1	1Host	0b1110	4 Upstream Sockets	4Links	0b011	(Socket 0 only)	Ln0	Ln0														
2C	1x2	1x2, 1x1	1Host	0b1110	4 Upstream Sockets	4Links	0b011	(Socket 0 only)	Ln0	Ln0														
2C	1x1	1x1	1Host	0b1110	4 Upstream Sockets	4Links	0b011	(Socket 0 only)	Ln0	Ln0														
2C	1x8 Option B	1x8, 1x4, 1x2, 1x1, 2x4, 2x2, 2x1	1Host	0b1101	4 Upstream Sockets	4Links	0b011	2x2	Ln0, Ln1	Ln1														
4C	2x8 Option B	1x8, 1x4, 2x4, 2x2, 2x1	1Host	0b1101	4 Upstream Sockets	4Links	0b011	(Socket 0 & 2 only)	Ln0	Ln0														
2C	1x8 Option D	2x4, 1x8, 1x4	1Host	0b1100	4 Upstream Sockets	4Links	0b011	4x2	Ln0	Ln0	Ln1	Ln1	Ln2	Ln2	Ln3	Ln3								
4C	1x8 Option D	4x2, (First 8 lanes), 4x1	1Host	0b1100	4 Upstream Sockets	4Links	0b011	4x2	Ln0	Ln0	Ln1	Ln1	Ln2	Ln2	Ln3	Ln3								
RSVD	RSVD	RSVD	1Host	0b0111	4 Upstream Sockets	4Links	0b011	-																
2C	2x4	2x4, 2x2, 2x1	1Host	0b0110	4 Upstream Sockets	4Links	0b011	2x2	Ln0	Ln0														
RSVD	RSVD	1x4, 1x2, 1x1	1Host	0b1001	4 Upstream Sockets	4Links	0b011	(Socket 0 & 2 only)	Ln0	Ln0	Ln1	Ln1	Ln2	Ln2	Ln3	Ln3								
2C	4x2	1x2, 1x1	1Host	0b1001	4 Upstream Sockets	4Links	0b011	4x2	Ln0	Ln0	Ln1	Ln1	Ln2	Ln2	Ln3	Ln3								
4C	1x8 Option A	1x8, 1x4, 1x2, 1x1	1Host	0b1000	4 Upstream Sockets	4Links	0b011	-																
4C	2x8 Option A	2x8, 2x4, 2x2, 2x1	1Host	0b0111	4 Upstream Sockets	4Links	0b011	1x2	Ln0	Ln0														
4C	2x8 Option A	1x8, 1x4, 1x2, 1x1	1Host	0b0110	4 Upstream Sockets	4Links	0b011	(Socket 0 only)	Ln0	Ln0														
4C	1x8 Option B	2x8, 2x4, 2x2, 2x1	1Host	0b0101	4 Upstream Sockets	4Links	0b011	(Socket 1 & 2 only)	Ln0	Ln0	Ln1	Ln1	Ln2	Ln2	Ln3	Ln3								
4C	1x8 Option B	1x8, 1x4, 2x4, 2x2, 2x1	1Host	0b0100	4 Upstream Sockets	4Links	0b011	(Socket 0 only)	Ln0	Ln0														
4C	1x8 Option C	2x8, 2x4, 2x2, 2x1	1Host	0b0100	4 Upstream Sockets	4Links	0b011	2x2	Ln0	Ln0	Ln1	Ln1	Ln2	Ln2	Ln3	Ln3								
4C	4x4	4x4, 1x2, 4x1	1Host	0b0011	4 Upstream Sockets	4Links	0b011	2x2	Ln0	Ln0	Ln1	Ln1	Ln2	Ln2	Ln3	Ln3								
RSVD	RSVD	RSVD	1Host	0b0010	4 Upstream Sockets	4Links	0b011	-																
RSVD	RSVD	RSVD	1Host	0b0001	4 Upstream Sockets	4Links	0b011	-																
RSVD	RSVD	RSVD	1Host	0b0000	4 Upstream Sockets	4Links	0b011	-																

Table 39: Bifurcation for Dual Host, Dual Sockets and Dual Upstream Links (BIF[2:0]#=#0b101)

Card Width	Card Name	Card Short Name	Supported Modes	Host	Upstream Devices	Upstream Links	BIF [2:0]#	Re-bus Link	Key: Cells shown as Link/Lane (e.g. Lk0/Ln0); HD - Host Disabled; Lane															
									Add-in-Card Encoding (P/N)	Ln 0					Ln 1					Ln 2				
										Lk0	Lk1	Lk2	Lk3	Lk4	Lk5	Lk6	Lk7	Lk8	Lk9	Lk10	Lk11	Lk12	Lk13	Lk14
2C	1x8 Option A	Card Not Present	1x8, 1x4, 1x2, 1x1	2 Host	2 Upstream Sockets	2 Links	0b001	-	Lk0: Lk0, Ln0	Lk0: Lk0, Ln0	Lk0: Lk0, Ln0	Lk0: Lk0, Ln0	Lk0: Lk0, Ln0	Lk0: Lk0, Ln0	Lk0: Lk0, Ln0	Lk0: Lk0, Ln0	Lk0: Lk0, Ln0	Lk0: Lk0, Ln0	Lk0: Lk0, Ln0	Lk0: Lk0, Ln0	Lk0: Lk0, Ln0	Lk0: Lk0, Ln0	Lk0: Lk0, Ln0	
2C	1x4	1x4, 1x2, 1x1	1x4, 1x2, 1x1	2 Host	2 Upstream Sockets	2 Links	0b001	2x8 (Host Only)	Lk0: Lk0, Ln0	Lk0: Lk0, Ln0	Lk0: Lk0, Ln0	Lk0: Lk0, Ln0	Lk0: Lk0, Ln0	Lk0: Lk0, Ln0	Lk0: Lk0, Ln0	Lk0: Lk0, Ln0	Lk0: Lk0, Ln0	Lk0: Lk0, Ln0	Lk0: Lk0, Ln0	Lk0: Lk0, Ln0	Lk0: Lk0, Ln0	Lk0: Lk0, Ln0	Lk0: Lk0, Ln0	
2C	1x2	1x2, 1x1	1x2, 1x1	2 Host	2 Upstream Sockets	2 Links	0b001	2x8 (Host Only)	Lk0: Lk0, Ln0	Lk0: Lk0, Ln0	Lk0: Lk0, Ln0	Lk0: Lk0, Ln0	Lk0: Lk0, Ln0	Lk0: Lk0, Ln0	Lk0: Lk0, Ln0	Lk0: Lk0, Ln0	Lk0: Lk0, Ln0	Lk0: Lk0, Ln0	Lk0: Lk0, Ln0	Lk0: Lk0, Ln0	Lk0: Lk0, Ln0	Lk0: Lk0, Ln0	Lk0: Lk0, Ln0	
2C	1x1	1x1	1x1	2 Host	2 Upstream Sockets	2 Links	0b001	2x8 (Host Only)	Lk0: Lk0, Ln0	Lk0: Lk0, Ln0	Lk0: Lk0, Ln0	Lk0: Lk0, Ln0	Lk0: Lk0, Ln0	Lk0: Lk0, Ln0	Lk0: Lk0, Ln0	Lk0: Lk0, Ln0	Lk0: Lk0, Ln0	Lk0: Lk0, Ln0	Lk0: Lk0, Ln0	Lk0: Lk0, Ln0	Lk0: Lk0, Ln0	Lk0: Lk0, Ln0	Lk0: Lk0, Ln0	
2C	1x8 Option B	2x8, 2x4, 2x2, 2x1	1x8, 1x4, 1x2, 1x1	2 Host	2 Upstream Sockets	2 Links	0b001	1x8	Lk0: Lk0, Ln0	Lk0: Lk0, Ln0	Lk0: Lk0, Ln0	Lk0: Lk0, Ln0	Lk0: Lk0, Ln0	Lk0: Lk0, Ln0	Lk0: Lk0, Ln0	Lk0: Lk0, Ln0	Lk0: Lk0, Ln0	Lk0: Lk0, Ln0	Lk0: Lk0, Ln0	Lk0: Lk0, Ln0	Lk0: Lk0, Ln0	Lk0: Lk0, Ln0	Lk0: Lk0, Ln0	
4C	2x8 Option B	4x4, 4x2, 4x1	2x8, 2x4, 2x2, 2x1	2 Host	2 Upstream Sockets	2 Links	0b001	2x8	Lk0: Lk0, Ln0	Lk0: Lk0, Ln0	Lk0: Lk0, Ln0	Lk0: Lk0, Ln0	Lk0: Lk0, Ln0	Lk0: Lk0, Ln0	Lk0: Lk0, Ln0	Lk0: Lk0, Ln0	Lk0: Lk0, Ln0	Lk0: Lk0, Ln0	Lk0: Lk0, Ln0	Lk0: Lk0, Ln0	Lk0: Lk0, Ln0	Lk0: Lk0, Ln0	Lk0: Lk0, Ln0	
2C	1x8 Option D	4x2 (First 8 lanes), 4x1	1x8, 1x4, 2x4, 2x2, 2x1	2 Host	2 Upstream Sockets	2 Links	0b001	2x8	Lk0: Lk0, Ln0	Lk0: Lk0, Ln0	Lk0: Lk0, Ln0	Lk0: Lk0, Ln0	Lk0: Lk0, Ln0	Lk0: Lk0, Ln0	Lk0: Lk0, Ln0	Lk0: Lk0, Ln0	Lk0: Lk0, Ln0	Lk0: Lk0, Ln0	Lk0: Lk0, Ln0	Lk0: Lk0, Ln0	Lk0: Lk0, Ln0	Lk0: Lk0, Ln0	Lk0: Lk0, Ln0	
4C	1x8 Option D	4x2 (First 8 lanes), 4x1	1x8, 1x4, 2x4, 2x2, 2x1	2 Host	2 Upstream Sockets	2 Links	0b001	2x8	Lk0: Lk0, Ln0	Lk0: Lk0, Ln0	Lk0: Lk0, Ln0	Lk0: Lk0, Ln0	Lk0: Lk0, Ln0	Lk0: Lk0, Ln0	Lk0: Lk0, Ln0	Lk0: Lk0, Ln0	Lk0: Lk0, Ln0	Lk0: Lk0, Ln0	Lk0: Lk0, Ln0	Lk0: Lk0, Ln0	Lk0: Lk0, Ln0	Lk0: Lk0, Ln0	Lk0: Lk0, Ln0	
RSVD	RSVD	RSVD	RSVD	2 Host	2 Upstream Sockets	2 Links	0b001	-	Lk0: Lk0, Ln0	Lk0: Lk0, Ln0	Lk0: Lk0, Ln0	Lk0: Lk0, Ln0	Lk0: Lk0, Ln0	Lk0: Lk0, Ln0	Lk0: Lk0, Ln0	Lk0: Lk0, Ln0	Lk0: Lk0, Ln0	Lk0: Lk0, Ln0	Lk0: Lk0, Ln0	Lk0: Lk0, Ln0	Lk0: Lk0, Ln0	Lk0: Lk0, Ln0	Lk0: Lk0, Ln0	
2C	2x4	4x2 (First 8 lanes), 4x1	1x4, 1x2, 1x1	2 Host	2 Upstream Sockets	2 Links	0b001	1x4	Lk0: Lk0, Ln0	Lk0: Lk0, Ln0	Lk0: Lk0, Ln0	Lk0: Lk0, Ln0	Lk0: Lk0, Ln0	Lk0: Lk0, Ln0	Lk0: Lk0, Ln0	Lk0: Lk0, Ln0	Lk0: Lk0, Ln0	Lk0: Lk0, Ln0	Lk0: Lk0, Ln0	Lk0: Lk0, Ln0	Lk0: Lk0, Ln0	Lk0: Lk0, Ln0	Lk0: Lk0, Ln0	
2C	4x2	2x2, 2x1	2x2, 2x1	2 Host	2 Upstream Sockets	2 Links	0b001	1x2	Lk0: Lk0, Ln0	Lk0: Lk0, Ln0	Lk0: Lk0, Ln0	Lk0: Lk0, Ln0	Lk0: Lk0, Ln0	Lk0: Lk0, Ln0	Lk0: Lk0, Ln0	Lk0: Lk0, Ln0	Lk0: Lk0, Ln0	Lk0: Lk0, Ln0	Lk0: Lk0, Ln0	Lk0: Lk0, Ln0	Lk0: Lk0, Ln0	Lk0: Lk0, Ln0	Lk0: Lk0, Ln0	
RSVD	RSVD	RSVD	RSVD	2 Host	2 Upstream Sockets	2 Links	0b001	-	Lk0: Lk0, Ln0	Lk0: Lk0, Ln0	Lk0: Lk0, Ln0	Lk0: Lk0, Ln0	Lk0: Lk0, Ln0	Lk0: Lk0, Ln0	Lk0: Lk0, Ln0	Lk0: Lk0, Ln0	Lk0: Lk0, Ln0	Lk0: Lk0, Ln0	Lk0: Lk0, Ln0	Lk0: Lk0, Ln0	Lk0: Lk0, Ln0	Lk0: Lk0, Ln0	Lk0: Lk0, Ln0	
4C	1x16 Option A	1x16, 1x8, 1x4, 1x2, 1x1	1x16, 1x8, 1x4, 1x2, 1x1	2 Host	2 Upstream Sockets	2 Links	0b001	1x8	Lk0: Lk0, Ln0	Lk0: Lk0, Ln0	Lk0: Lk0, Ln0	Lk0: Lk0, Ln0	Lk0: Lk0, Ln0	Lk0: Lk0, Ln0	Lk0: Lk0, Ln0	Lk0: Lk0, Ln0	Lk0: Lk0, Ln0	Lk0: Lk0, Ln0	Lk0: Lk0, Ln0	Lk0: Lk0, Ln0	Lk0: Lk0, Ln0	Lk0: Lk0, Ln0	Lk0: Lk0, Ln0	
4C	2x8 Option A	2x8, 2x4, 2x2, 2x1	2x8, 2x4, 2x2, 2x1	2 Host	2 Upstream Sockets	2 Links	0b001	2x8	Lk0: Lk0, Ln0	Lk0: Lk0, Ln0	Lk0: Lk0, Ln0	Lk0: Lk0, Ln0	Lk0: Lk0, Ln0	Lk0: Lk0, Ln0	Lk0: Lk0, Ln0	Lk0: Lk0, Ln0	Lk0: Lk0, Ln0	Lk0: Lk0, Ln0	Lk0: Lk0, Ln0	Lk0: Lk0, Ln0	Lk0: Lk0, Ln0	Lk0: Lk0, Ln0	Lk0: Lk0, Ln0	
4C	1x16 Option B	1x16, 1x8, 1x4, 1x2, 1x1	1x16, 1x8, 1x4, 1x2, 1x1	2 Host	2 Upstream Sockets	2 Links	0b001	2x8	Lk0: Lk0, Ln0	Lk0: Lk0, Ln0	Lk0: Lk0, Ln0	Lk0: Lk0, Ln0	Lk0: Lk0, Ln0	Lk0: Lk0, Ln0	Lk0: Lk0, Ln0	Lk0: Lk0, Ln0	Lk0: Lk0, Ln0	Lk0: Lk0, Ln0	Lk0: Lk0, Ln0	Lk0: Lk0, Ln0	Lk0: Lk0, Ln0	Lk0: Lk0, Ln0	Lk0: Lk0, Ln0	
4C	1x16 Option C	2x8, 2x4, 2x2, 2x1	2x8, 2x4, 2x2, 2x1	2 Host	2 Upstream Sockets	2 Links	0b001	2x8	Lk0: Lk0, Ln0	Lk0: Lk0, Ln0	Lk0: Lk0, Ln0	Lk0: Lk0, Ln0	Lk0: Lk0, Ln0	Lk0: Lk0, Ln0	Lk0: Lk0, Ln0	Lk0: Lk0, Ln0	Lk0: Lk0, Ln0	Lk0: Lk0, Ln0	Lk0: Lk0, Ln0	Lk0: Lk0, Ln0	Lk0: Lk0, Ln0	Lk0: Lk0, Ln0	Lk0: Lk0, Ln0	
4C	1x16 Option D	4x4, 4x2, 4x1	4x4, 4x2, 4x1	2 Host	2 Upstream Sockets	2 Links	0b001	2x4	Lk0: Lk0, Ln0	Lk0: Lk0, Ln0	Lk0: Lk0, Ln0	Lk0: Lk0, Ln0	Lk0: Lk0, Ln0	Lk0: Lk0, Ln0	Lk0: Lk0, Ln0	Lk0: Lk0, Ln0	Lk0: Lk0, Ln0	Lk0: Lk0, Ln0	Lk0: Lk0, Ln0	Lk0: Lk0, Ln0	Lk0: Lk0, Ln0	Lk0: Lk0, Ln0	Lk0: Lk0, Ln0	
RSVD	RSVD	RSVD	RSVD	2 Host	2 Upstream Sockets	2 Links	0b001	[EF 0 and 2 only]	Lk0: Lk0, Ln0	Lk0: Lk0, Ln0	Lk0: Lk0, Ln0	Lk0: Lk0, Ln0	Lk0: Lk0, Ln0	Lk0: Lk0, Ln0	Lk0: Lk0, Ln0	Lk0: Lk0, Ln0	Lk0: Lk0, Ln0	Lk0: Lk0, Ln0	Lk0: Lk0, Ln0	Lk0: Lk0, Ln0	Lk0: Lk0, Ln0	Lk0: Lk0, Ln0	Lk0: Lk0, Ln0	
RSVD	RSVD	RSVD	RSVD	2 Host	2 Upstream Sockets	2 Links	0b001	-	Lk0: Lk0, Ln0	Lk0: Lk0, Ln0	Lk0: Lk0, Ln0	Lk0: Lk0, Ln0	Lk0: Lk0, Ln0	Lk0: Lk0, Ln0	Lk0: Lk0, Ln0	Lk0: Lk0, Ln0	Lk0: Lk0, Ln0	Lk0: Lk0, Ln0	Lk0: Lk0, Ln0	Lk0: Lk0, Ln0	Lk0: Lk0, Ln0	Lk0: Lk0, Ln0	Lk0: Lk0, Ln0	
RSVD	RSVD	RSVD	RSVD	2 Host	2 Upstream Sockets	2 Links	0b001	-	Lk0: Lk0, Ln0	Lk0: Lk0, Ln0	Lk0: Lk0, Ln0	Lk0: Lk0, Ln0	Lk0: Lk0, Ln0	Lk0: Lk0, Ln0	Lk0: Lk0, Ln0	Lk0: Lk0, Ln0	Lk0: Lk0, Ln0	Lk0: Lk0, Ln0	Lk0: Lk0, Ln0	Lk0: Lk0, Ln0	Lk0: Lk0, Ln0	Lk0: Lk0, Ln0	Lk0: Lk0, Ln0	

3.7 Port Numbering and LED Implementations

The OCP NIC 3.0 I/O bracket shall provide port labeling for user identification.

LEDs shall be implemented on the OCP NIC 3.0 I/O bracket when there is sufficient space for local indication. LEDs are typically placed on the primary side. LEDs may be optionally implemented on the secondary side of the card for space constrained implementations. LEDs may be remotely implemented on the card Scan Chain (as defined in Section ~~3.4.53.4.5~~) for link/activity indication on the baseboard. LED configurations for the local and remote cases are described in the sections below. In all cases, the actual link rate may be directly queried through the management interface.

3.7.1 OCP NIC 3.0 Port Naming and Port Numbering

The numbering of all OCP NIC 3.0 external ports shall start from Port 1. When oriented with the primary side components facing up and viewing directly into the port, Port 1 shall be located on the left hand side. The port numbers shall sequentially increase to the right. Refer to ~~Figure 98~~[Figure 92](#) as an example implementation.

3.7.2 OCP NIC 3.0 Card LED Configuration

For low I/O count ~~small form factor~~[SFF](#) cards without built in light pipes (such as 1x QSFP, 2x QSFP, 2x SFP, or 2x RJ-45), or ~~a large form factor~~[LFF](#) cards, where additional I/O bracket area is available, the card shall locally implement on-board link/activity indications. The card may additionally implement LEDs on the optional Scan Chain data stream.

For 4x SFP, a permissible LED implementation may include right angle SMT mount LEDs placed on the secondary side of the OCP NIC 3.0 card. The LEDs shall be located below the line side I/O cages.

Note: Depending on the end faceplate implementation (e.g. with an ejector latch), the secondary side LED implementation may be obstructed and biased to the left to prevent interference with the ejector cam mechanism.

The recommended local (on-card) LED implementation uses two physical LEDs (a bicolored Speed A/Speed B Link LED and a discrete Activity LED). ~~Table 36~~[Table 42](#) describes the OCP NIC 3.0 card LED implementations.

The LEDs shall be uniformly illuminated across the indicator surface. LED surfaces with a diffusion treatment are preferred. For ease of indication within the operating environment, all OCP NIC 3.0 cards shall implement measures to prevent bleed-through between LED indicators and ~~its~~[their](#) surrounding chassis components.

Table 3642: OCP NIC 3.0 Card LED Configuration with Two Physical LEDs per Port

LED Pin	LED Color	Description
Link	Green	Active low. Bicolor multifunction LED.
	Amber	<p>This LED shall be used to indicate link.</p> <p>When the link is up, then this LED shall be lit and solid. This indicates that the link is established, there are no local or remote faults, and the link is ready for data packet transmission/reception.</p> <p>The LED is Green when the port is linked at its maximum speed. The LED is Amber when the port is not linked <u>but not operating</u> at the highest speed.</p> <p>The LED is off when no link is present.</p> <p>For silicon with limited I/O, the Amber LED may be omitted. In this case, the Green LED shall simply indicate link is up at any configured speed.</p> <p>The illuminated Link LED indicator may <u>be</u> blinked and used for port identification through vendor specific link diagnostic software.</p> <p>The Link LED shall be located on the left hand side or located on the top for each port when the OCP NIC 3.0 card is viewed in the horizontal plane.</p> <p>For serviceability, green LEDs shall emit light at a wavelength between 513_nm and 537_nm while amber LEDs shall emit light at a wavelength between 580_nm and 589_nm.</p> <p>For uniformity across OCP NIC 3.0 products, all link LEDs shall have its <u>their</u> luminance across the total surface area measured in millicandelas (mcd) with an average value between TBD_12 mcd to TBD_18 mcd.</p>
	Off	
Activity	Green	Active low.
	Off	<p>When the link is up and there is no activity, this LED shall be lit and solid.</p> <p>When the link is up and there is link activity, then this LED should blink at the interval-rate of <u>1/2 Hz to 5 Hz</u> 50-500ms during link activity.</p> <p>The activity LED shall be located on the right hand side or located on the bottom for each port when the OCP NIC 3.0 card is viewed in the horizontal plane.</p>

		<p>For serviceability, green LEDs shall emit light at a wavelength between 513_{nm} and 537_{nm}.</p> <p>For uniformity across OCP NIC 3.0 products, all activity LEDs shall have its<u>their</u> luminance across the total surface area measured in millicandelas (mcd) with an average value between 780-12<u>780-12</u> mcd and 780-18<u>780-18</u> mcd.</p>
--	--	---

3.7.3 OCP NIC 3.0 Card LED Ordering

For all OCP NIC 3.0 card use cases, each port shall implement the green/amber Link LED and a green activity LED. For I/O limited silicon, the amber LED may be omitted.

When the OCP NIC 3.0 card is viewed from the horizontal position, and with the primary component side facing up, the Link LED shall be located on the left side and the activity LED shall be located on the right. The LED placement may also make use of a stacked LED assembly, or light pipe in the vertical axis. In this case, the Link Activity LED shall be on the top of the stack, and the Activity LED shall be on the bottom of the stack when viewed from the horizontal position. In all cases, the port ordering shall increase from left to right when viewed from the same horizontal position.

The actual placement of the Link and Activity LEDs on the faceplate may be left up to the discretion of the OCP NIC 3.0 card designer. The LED port association ~~shall~~should be clearly labeled on the OCP NIC 3.0 card if the space allows. Similarly, the LED for link and the LED for Activity indication ~~shall~~should also be marked on the faceplate.

For 4xSFP configurations, the LEDs may be placed on the secondary side of the card using right-angle SMT components. OCP NIC 3.0 designers may opt to use the scan chain LEDs instead or in addition to the on-card indicators.

Figure 9892: Port and LED Ordering – Example SFF Link/Activity and Speed LED Placement

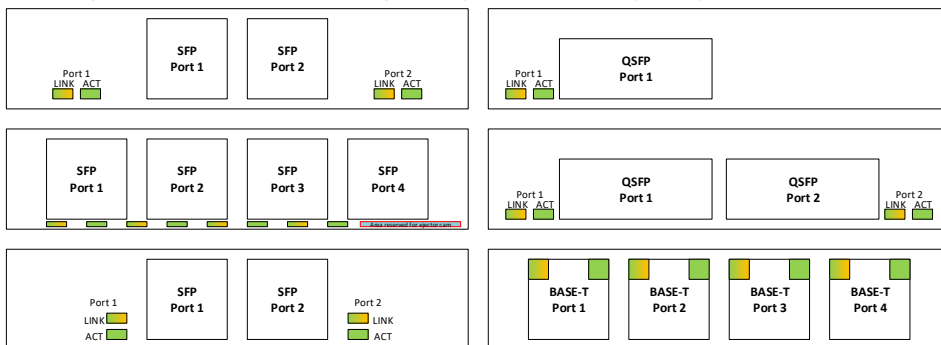

Note 1: The example port and LED ordering diagrams shown in ~~Figure 98~~Figure 92 are viewed with the card in the horizontal position and the primary side is facing up.

Note 2: The 4xSFP LED implementation is biased to the left to allow clearance for the ejector latch cam.

3.7.4 Baseboard LEDs Configuration over the Scan Chain

A ~~small form factor~~SFF OCP NIC 3.0 ~~card~~ with a fully populated I/O bracket (2x QSFP, 4x SFP or 4x RJ-45) does not have sufficient space for primary-side discrete on-board (faceplate) LED indicators. Section 3.7.23-8-2 presents an implementation for placing LEDs on the secondary side..

In this scenario, the line side link and activity LED indicators are implemented on the baseboard system via the Scan Chain for remote indication. The Scan Chain bit stream is defined in Section 3.4.53-4.5.

The baseboard LED implementation uses two discrete LEDs – a green/amber Link LED and a discrete green Activity. The physical baseboard LED implementation is left up to the baseboard vendor and is not defined in this specification. The LED implementation is optional for baseboards.

For serviceability, green LEDs shall emit light at a wavelength between 513_nm and 537_nm while amber LEDs shall emit light at a wavelength between 580_nm and 589_nm.

At the time of this writing, the Scan Chain definition allows for up to two link and one activity LED per port. A total of up to 8 ports are supported in the Scan Chain. The bit stream defines the LEDs to be active low (on). The Scan Chain LED implementation allows the NIC LED indicators to be remotely located on the OCP NIC 3.0 compliant chassis (e.g. front LED indicators with rear I/O cards).

3.8 Power Capacity and Power Delivery

There are four permissible power states: NIC Power Off, ID Mode, Aux Power Mode (S5), and Main Power Mode (S0). The transition of these states is shown in Figure 9993. The max available power envelopes for each of these states are defined in Table 37Table 43.

Figure 9993: Baseboard Power States

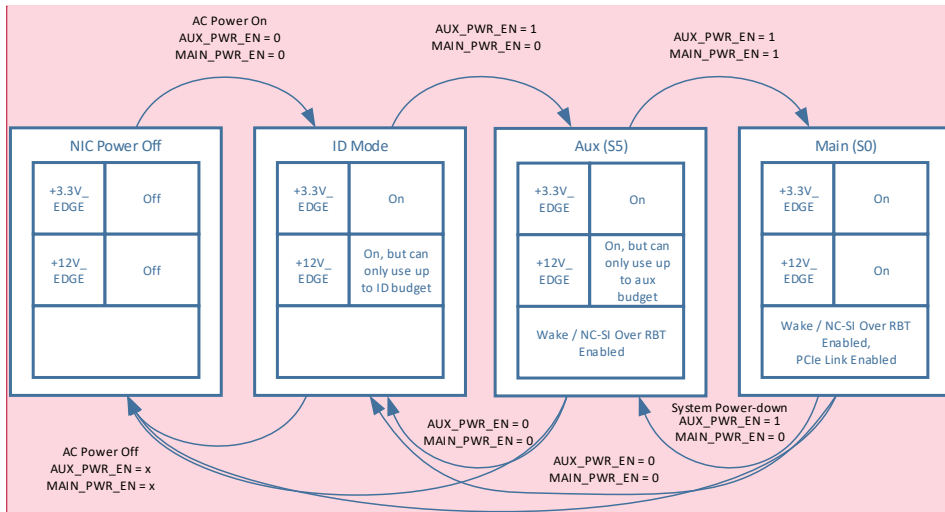

Commented [NT6]: Power state machine and sequencing diagrams need more detail. ... e.g. inclusion of the transition states and when isolators are disabled/enabled for 0v90. Include RBT_ISOLATE#

Table 3743: Power States

Power State	AUX_PWR_EN	MAIN_PWR_EN	PERSTn	FRU	Scan Chain	WAKEn	RBT Link	PCIe Link	+3.3V_EDGE	+12V_EDGE
NIC Power Off	Low	Low	Low							
ID Mode	Low	Low	Low	X	X ¹				X	X
Aux Power Mode (S5)	High	Low	Low	X	X	X	X		X	X
Main Power Mode (S0)	High	High	High	X	X	X	X	X	X	X

Note 1: Only the PRSNTB[0:3]# scan chain signals are valid in ID mode as the OCP NIC 3.0 card power rails have not yet been enabled via the AUX_PWR_EN/MAIN_PWR_EN signals.

3.8.1 NIC Power Off

In NIC power off mode, all power delivery has been turned off or disconnected from the baseboard. Transition to this state can be from any other state.

3.8.2 ID Mode

In the ID Mode, only +3.3V_EDGE is available for powering up management only functions. Only FRU and scan chain accesses are allowed in this mode. Only the card PRSNTB[0:3]# bits are valid on the chain in this mode as the OCP NIC 3.0 card power rails have not yet been enabled via the AUX_PWR_EN and MAIN_PWR_EN signals. The WAKE#, TEMP_WARN#, TEMP_CRIT#, Link and Activity bits are invalid and should be masked by the baseboard in ID Mode.

The +12V_EDGE rail is not intended to be used in ID Mode, however leakage current may be present. The max leakage is defined in Section [3.93-10](#). An OCP NIC 3.0 card shall transition to this mode when AUX_PWR_EN=0 and MAIN_PWR_EN=0.

3.8.3 Aux Power Mode (S5)

In Aux Power Mode provides both +3.3V_EDGE as well as +12V_EDGE is available. +12V_EDGE in Aux mode may be used to deliver power to the OCP NIC 3.0 card, but only up to the Aux mode budget as defined in [Table 38Table 44](#). An OCP NIC 3.0 card shall transition to this mode when AUX_PWR_EN=1, MAIN_PWR_EN=0, NIC_PWR_GOOD=1 and the duration (T_{APL}) has passed for the ID-Aux Power Mode ramp. This guarantees the ID mode to Aux Power Mode transition (as shown in [Figure 100Figure 94](#)) has completed and all Aux Power Mode rails are within operating tolerances. The WAKE#, TEMP_WARN#, and TEMP_CRIT# bits shall not sampled until these conditions are met.

3.8.4 Main Power Mode (S0)

In Main Power Mode provides both +3.3V_EDGE and +12V_EDGE across the OCP connector. The OCP NIC 3.0 card operates in full capacity. Up to 80_W may be delivered on +12V_EDGE for a SFF Card and up to 150_W for a LFF Card. Additionally, up to 3.63_W is delivered on each +3.3V_EDGE pin. An OCP NIC 3.0 card shall transition to this mode when AUX_PWR_EN=1, MAIN_PWR_EN=1, NIC_PWR_GOOD=1 and the duration (T_{MPL}) has passed for the Aux-Main Power Mode ramp. This guarantees the Aux Power Mode to Main Power Mode transition (as shown in [Figure 100Figure 94](#)) has completed and all Main Power Mode rails are within operating tolerances. The WAKE#, TEMP_WARN#, and TEMP_CRIT# bits shall not sampled until these conditions are met.

3.9 Power Supply Rail Requirements and Slot Power Envelopes

The baseboard provides +3.3V_EDGE and +12V_EDGE to both the Primary and Secondary Connectors. The rail requirements are leveraged from the PCIe CEM 4.0 specification. For OCP NIC 3.0 cards, the requirements are as follows:

Table 3844: Baseboard Power Supply Rail Requirements – Slot Power Envelopes

Power Rail	15 W Slot SFF Hot Aisle	25 W Slot SFF Hot Aisle	35 W Slot SFF Hot Aisle	80 W Slot SFF Cold Aisle	150 W LFF Cold Aisle
+3.3V_EDGE					
Voltage Tolerance	±9% (max)	±9% (max)	±9% (max)	±9% (max)	±9% (max)
Supply Current					
ID Mode	100_mA (max)	100_mA (max)	100_mA (max)	100_mA (max)	100_mA (max)
Aux Mode	1.1_A (max)	1.1_A (max)	1.1_A (max)	1.1_A (max)	2.2_A (max)
Main Mode	1.1_A (max)	1.1_A (max)	1.1_A (max)	1.1_A (max)	2.2_A (max)
Capacitive Load	150_μF (max)	150_μF (max)	150_μF (max)	150_μF (max)	300_μF (max)
+12V_EDGE					
Voltage Tolerance	+8/-12% (max)	+8/-12% (max)	+8/-12% (max)	+8/-12% (max)	+8/-12% (max)
Supply Current					
ID Mode	50_mA (max)	50_mA (max)	50_mA (max)	50_mA (max)	50_mA (max)
Aux Mode	0.7_A (max)	1.1_A (max)	1.5_A (max)	3.3_A (max)	6.3_A (max)
Main Mode	1.25_A (max)	2.1_A (max)	2.9_A (max)	6.6_A (max)	12.5_A (max)
Capacitive Load	500_μF (max)	500_μF (max)	500_μF (max)	500_μF (max)	1000_μF (max)

Note 1: While cards may draw up to the published power ratings, the baseboard vendor shall evaluate its cooling capacity for each slot power envelope to determine if a transition to Aux Power Mode is allowed.

Note 2: The maximum slew rate for each OCP NIC 3.0 card shall be no more than 0.1_A/μs per the PCIe CEM specification.

Note 3: Each OCP NIC 3.0 card shall limit the bulk capacitance to the max values published (500_μF for a [Small Form Factor SFF](#) card, 1000_μF for a [Large Form Factor LFF](#) card).

Note 4: For systems that implement hot plug, the baseboard shall limit the voltage slew rate such that the instantaneous inrush current shall not exceed the specified max current. The equation is defined in the PCIe CEM specification and is $dV/dt = I/C$; where:

I = max allowed current (A)

C = max allowed bulk capacitance (F)

dV/dt = maximum allowed voltage slew rate (V/s)

The OCP NIC 3.0 FRU definition provides a record for the max power consumption of the card. This value shall be used to aid in determining if the card may be enabled in a given OCP slot. Refer to Section 4.10.2 for the available FRU records.

Additionally, the baseboard shall advertise its slot power limits to aid in the overall board power budget allocation to prevent a high power card from being enabled in a lower power class slot. This is

implemented via the Slot Power Limit Control mechanism as defined in the PCIe Base Specification. The end point silicon will power up in a low power state until power is negotiated.

3.10 Hot Swap Considerations for +12V_EDGE and +3.3V_EDGE Rails

Hot plug and hot swap support is optional for baseboard implementers. However, the OCP NIC 3.0 form factor lends itself to potential hot plug and removal events while the baseboard is powered on. These events need to be carefully orchestrated with the ~~system~~ operating system and ~~system~~ management entity to prevent a system hang. A surprise extraction may occur in some instances when resources have not been quiesced and the card is removed. Many aspects of the system are involved in processing such an event in both cases. The current scope of this specification does not define an overall hardware or software system architecture to support hot plug. Instead, this specification only highlights the hardware elements that can be utilized to support hot plug for implementations.

The system implementer shall consider the use of hot_swap controllers on both the +12V_EDGE and +3.3V_EDGE pins to prevent damage to the baseboard or the OCP NIC 3.0 card. Hot_swap controllers ~~help limit with the~~ in-rush current ~~limiting~~ while also providing overcurrent ~~protection~~, undervoltage and overvoltage protection capabilities.

The hot swap controller may gate the +12V_EDGE and +3.3V_EDGE based on the PRSNTB[3:0]# value. Per Section 3.5.3, a card is present in the system when the encoded value is not 0b1111. The PRSNTB[3:0]# may be AND'ed together and connected to the hot_swap controller to accomplish this result. Per the OCP NIC 3.0 mechanical definition (Section 3.1.1), the present pins are short pins and engage only when the card is positively seated.

The PRSNTB[3:0]# pins are used to detect an OCP 3.0 NIC card insertion and removal event. The card type detection is described in Section 3.5. Through the use of in-band signaling, the PCIe link may be enabled to periodically train when a card is plugged in. Similarly, the signals may be used to detect a card removal. The card type is determined by querying the FRU data over the SMBus.

At the time of this writing, the DSP0222 Network Controller Sideband Interface (NC-SI) Specification does not define a mechanism to discover hot-plug support. Future work is needed for supporting this feature on NCSI over RBT interfaces.

Baseboards that do not support hot insertion, or hot extractions may opt to not implement these features.

3.11 Power Sequence Timing Requirements

The following figure shows the power sequence of PRSNTB[3:0]#, +3.3V_EDGE, +12V_EDGE relative to AUX_PWR_EN, [RBT_ISOLATE#](#), BIF[2:0]#, MAIN_PWR_EN, PERSTn*, and PCIe REFCLK stable on the baseboard. Additionally the OCP NIC 3.0 card power ramp, and NIC_PWR_GOOD are shown. Please refer to Section [3.4.63-4.6](#) for the NIC_PWR_GOOD definition. Refer to DMTF DSP0222 for details on the NC-SI [controller and](#) clock startup requirements.

Figure ~~10094~~: [Power-Up Sequencing](#)

Commented [NT7]: From Hung Phu (HPE) 9/26/2018:

Additional timing parameters to consider:

1) ID Mode Ready: Spec minimum time from system power in regulation to when system can start reading data from NIC cards in ID Mode. Seeking NIC vendors worst case timing for all intended devices that are avail in ID Mode.

2) BIF[0:2]# pins valid at AUX_PWR_EN assertion is problematic for dynamic bifurcation.. Possibly move BIF[0:2]# valid to prior NIC_PWR_GOOD but the timing need to be specified to prevent concerns w/ system driving unpowered (or ramping) I/O pins.

Proposal:

- a. System drives BIF[0:2]# after NIC_PWR_GOOD and NIC card can latch BIF[0:2]# with MAIN_PWR_EN. This may be a non-starter for single power domain card.
- b. Spec minimum ramp time for NIC_Power_Ramp (Aux) or minimum time after AUX_PWR_EN so the system can safely drive BIF[0:2]#.

3) Propose to add NC-SI start-up timing from DMTF DSP0222 spec of "T4 – Network Controller Power up ready interval – 2s max" from NIC_PWR_GOOD to RBT ready to power-up sequence in Fig 94. RBT can also be shown to be isolated prior to this timing.

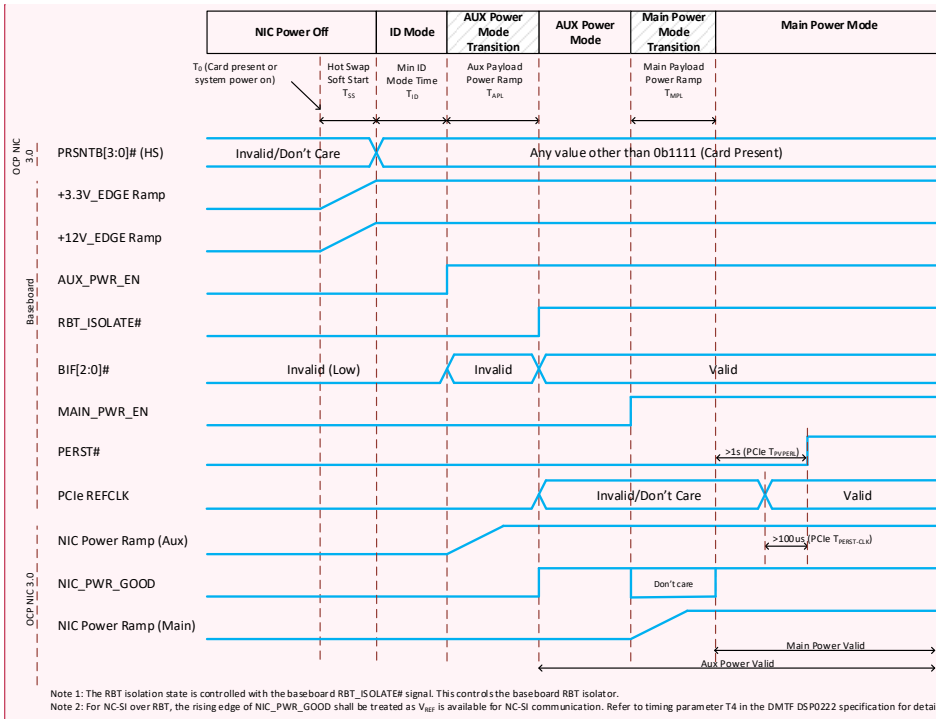

Open Compute Project • OCP NIC 3.0

Rev 0.840-83

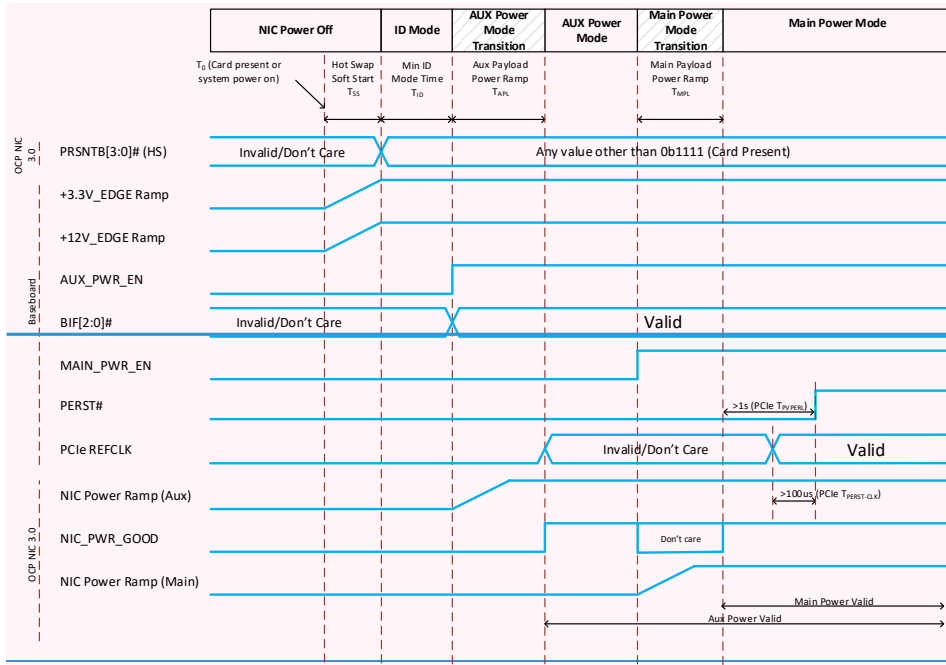

Commented [NT8]: Include RBT_ISOLATE# for Ov90.

Figure ~~10195~~: Power-Down Sequencing

Commented [NT9]:

From Hung Phu (HPE) 9/26/2018

1)For dynamic bifurcation use case where 3_3V_EDGE/12V_EDGE are still up, need minimum time duration for AUX_PWR_EN and MAIN_PWR_EN to stay down for NIC cards to completely discharge downstream VRs to prevent unintended side effect if the system come back up too fast.

2)Taux-ID <=100uS in diagram. Table 37 shows Taux-ID = 10ms?

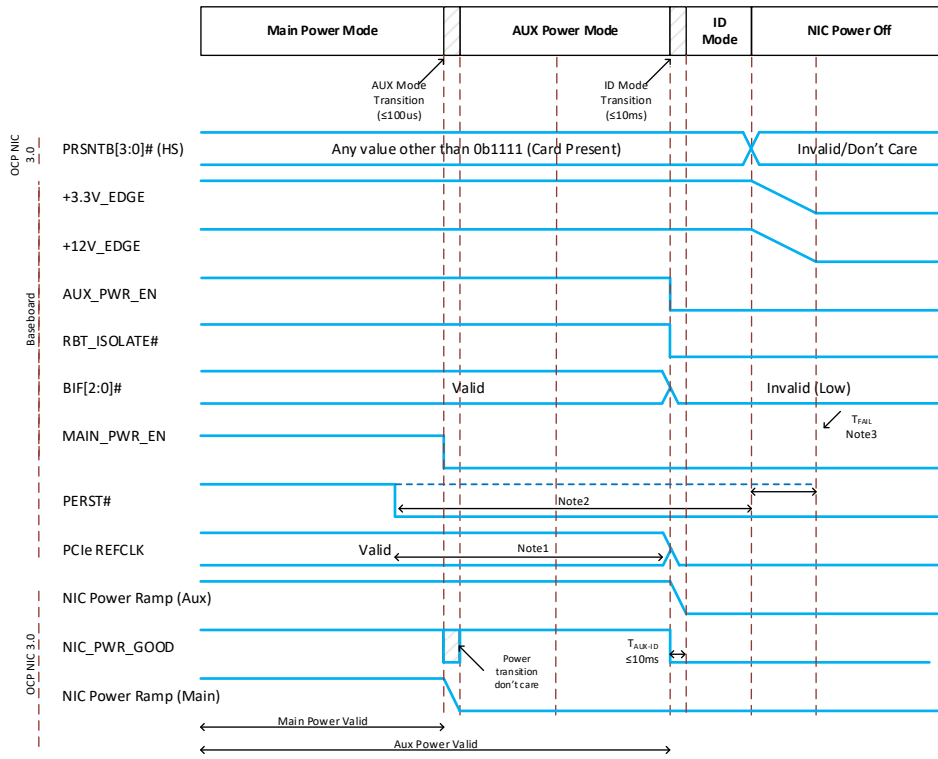

Note1: REFCLK go inactive after PERST# goes active. (PCIe CEM Section 2.2.3)
 Note2: PERST# goes active before the power on the connector is removed. (PCIe CEM Section 2.2.3)
 Note3: In the case of a surprise power down, PERST# goes active T_{FALL} after power is no longer stable.

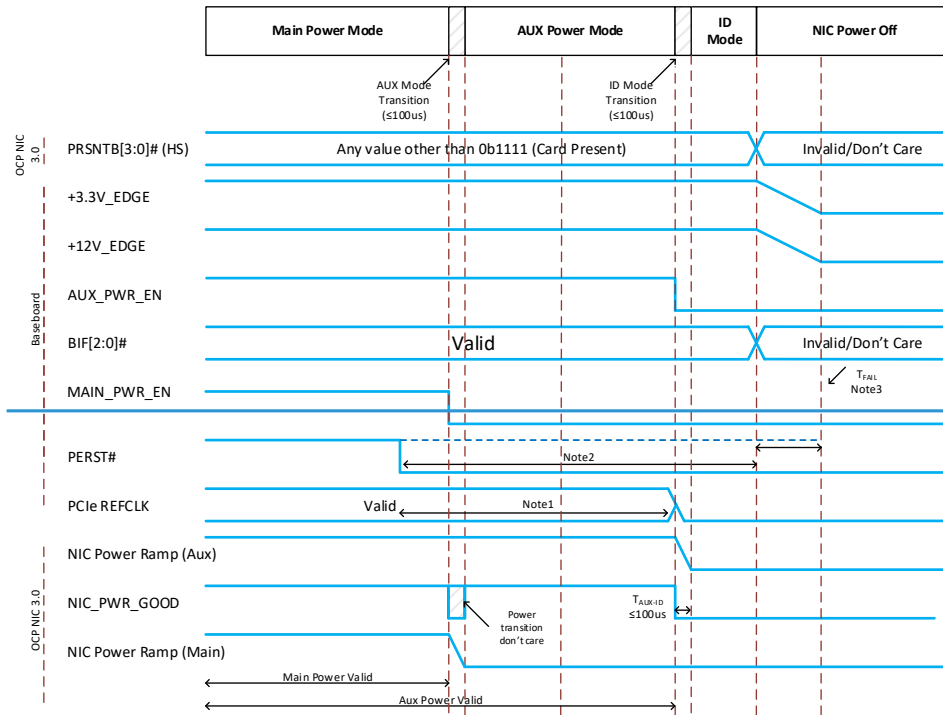

Note1: REFCLK go inactive after PERST# goes active. (PCIe CEM Section 2.2.3)
 Note2: PERST# goes active before the power on the connector is removed. (PCIe CEM Section 2.2.3)
 Note3: In the case of a surprise power down, PERST# goes active T_{FALL} after power is no longer stable.

Table 3945: Power Sequencing Parameters

Parameter	Value	Units	Description
T_{SS}	20	ms	Maximum time between system +3.3V_EDGE and +12V_EDGE ramp to power stable. This parameter is only applicable to hot swap controller-based implementations. For non-hot swap applications, the +3.3V_EDGE and +12V_EDGE ramp is system dependent.
$T_{SCAN\ RDY}$	1	ms	Minimum time required between +3.3V_EDGE stable to the first scan chain data valid read.
T_{ID}	20	ms	Minimum guaranteed time per spec to spend in ID mode.
T_{APL}	25	ms	Maximum time between AUX_PWR_EN assertion and t_e NIC_PWR_GOOD assertion.
T_{MPL}	25	ms	Maximum time between MAIN_PWR_EN assertion and t_e NIC_PWR_GOOD assertion.

T _{PVPERL}	1	s	Minimum time between NIC_PWR_GOOD assertion in Main Power Mode and PERST# deassertion. For OCP NIC 3.0 applications, this value is >1 second. This is longer than the minimum value specified in the PCIe CEM Specification, Rev 4.0.
T4	2	s	Maximum time interval from when the network controller NC-SI over RBT interface is able to respond to commands. The parameter T4 is defined in the DSP0222 specification and is measured from when V_{REF} becomes available. For OCP NIC 3.0, the value T4 is measured from the deassertion of RBT_ISOLATE#.
T _{PERST-CLK}	100	μs	Minimum Time PCIe REFCLK is stable before PERST# inactive.
T _{FAIL}	500	ns	In the case of a surprise power down, PERST# goes active at minimum T _{FAIL} after power is no longer stable.
T _{AUX-ID}	10	ms	Maximum time from AUX_PWR_EN deassertion to NIC_PWR_GOOD deassertion.

3.12 Digital I/O Specifications

All digital I/O pins on the connector boundary are +3.3V signaling levels. [Table 40Table-46](#) following tables provide the absolute max levels. Refer to the appropriate specifications for the RBT, PCIe and SMBus DC/AC specifications.

Table [4Q46](#): Digital I/O DC specifications

Symbol	Parameter	Min	Max	Units	Note
V _{OH}	Output voltage		3.6	V	
V _{OL}	Output low voltage		0.8	V	
I _{OH}	Output high current			mA	
I _{OH}	Output low current			mA	
V _{IH}	Input voltage		3.6	V	
V _{IL}	Input low voltage		0.8	V	
I _{OH}	Input current			mA	

Table [4147](#): Digital I/O AC specifications

Symbol	Parameter	Min	Max	Units	Note
T _{OR}	Output rise time			ns	
T _{OF}	Output fall time			ns	

4 Management and Pre-OS Requirements

OCP NIC 3.0 card management is an important aspect to overall system management. This section specifies a common set of management requirements for OCP NIC 3.0 implementations. There are three types of implementations (RBT+MCTP Type, RBT Type, and MCTP Type) depending on the physical sideband management interfaces, transports, and traffic supported over different transports. An OCP NIC 3.0 implementation shall support at least one type of implementation for card management. For a given type of implementation, an OCP NIC 3.0 card shall support type specific requirements described in Sections 4.1 through 4.7.

Table 4248: OCP NIC 3.0 Management Implementation Definitions

Management Type	Definition
RBT Type	The RBT Type management interface is exclusive to the Reduced Media Independent Interface (RMII) Based Transport (RBT). The NIC card is required to support the DSP0222 Network Controller Sideband Interface (NC-SI) Specification for this management
RBT+MCTP Type	The RBT+MCTP management interface supports both the RBT and MCTP standards, specifically the DSP0222 Network Controller Sideband Interface (NC-SI) Specification, DSP0236 Management Component Transport Protocol (MCTP) Base Specification, and the associated binding specifications. This is the preferred management implementation for baseboard NIC cards. See MCTP Type below for more details
MCTP Type	The MCTP management interface supports MCTP standards specifically the DSP0236 Management Component Transport Protocol (MCTP) Base Specification and the associated binding specifications.

4.1 Sideband Management Interface and Transport

OCP NIC 3.0 sideband management interfaces are used by a Management Controller (MC) or Baseboard Management Controller (BMC) to communicate with the NIC. [Table 43Table 49](#) summarizes the sideband management interface and transport requirements.

Table 4349: Sideband Management Interface and Transport Requirements

Requirement	RBT+MCTP Type	RBT Type	MCTP Type
NC-SI 1.1 compliant RMII Based Transport (RBT) including physical interface defined in Section 10 of DMTF DSP0222	Required	Required	N/A
I ² C compliant physical interface for FRU EEPROM	Required	Required	Required
SMBus 2.0 compliant physical interface	Required	N/A	Required
Management Component Transport Protocol (MCTP) Base 1.3 (DSP0236 1.3 compliant) over MCTP/SMBus Binding (DSP0237 1.1 compliant)	Required	N/A	Required
PCIe VDM compliant physical interface	Optional	Optional	Optional
Management Component Transport Protocol (MCTP) Base 1.3 (DSP0236 1.3 compliant) over MCTP/PCIe VDM Binding (DSP0238 1.0 compliant)	Optional	Optional	Optional

4.2 NC-SI Traffic

DMTF DSP0222 defines two types of NC-SI traffic: Pass-Through and Control. ~~Table 44~~Table 50 summarizes the NC-SI traffic requirements.

Table ~~44~~50: NC-SI Traffic Requirements

Requirement	RBT+MCTP Type	RBT Type	MCTP Type
NC-SI Control over RBT (DMTF DSP0222 1-1 or later compliant)	Required	Required	N/A
NC-SI Control over MCTP (DMTF DSP0261 1-2 compliant)	Required	N/A	Required
NC-SI Pass-Through over RBT (DMTF DSP0222 1-1 compliant)	Required	Required	N/A
NC-SI Pass-Through over MCTP (DMTF DSP0261 1-2 compliant)	Optional	N/A	Optional

Note: A Management Controller (MC) is allowed to use NC-SI Control traffic only without enabling NC-SI pass-through.

4.3 Management Controller (MC) MAC Address Provisioning

An OCP NIC 3.0 compliant card that supports NC-SI pass-through shall provision one or more MAC addresses per Package (refer to the Package definition as detailed in the DMTF DSP0222 specification) for Out-Of-Band (OOB) management traffic. The number of MC MAC addresses provisioned is implementation dependent. These MAC addresses are not exposed to the host(s) as available MAC addresses. The MC is not required to use these provisioned MAC addresses. ~~Table 45~~Table 51 summarizes the MC MAC address provisioning requirements.

Table ~~45~~51: MC MAC Address Provisioning Requirements

Requirement	RBT+MCTP Type	RBT Type	MCTP Type
<p>One or more MAC Addresses per package shall be provisioned for the MC.</p> <p>The OCP NIC 3.0 platform may choose to use the NIC vendor allocated MAC addresses for the BMC.</p> <p>The usage of provisioned MAC addresses are BMC implementation specific and is outside the scope of this specification.</p> <p>The recommended MAC address allocation scheme is stated below.</p> <p>Assumptions:</p> <ol style="list-style-type: none"> The number of BMCs or virtual BMCs is the same as the number of hosts (1:1 relationship between each host and the BMC). 	Required	Required	Optional

<p>2. The maximum number of partitions on each port is the same.</p> <p>Variables:</p> <ul style="list-style-type: none"> • <code>num_ports</code> – Number of Ports on the OCP NIC 3.0 card • <code>max_parts</code> – Maximum number of partitions on a port • <code>num_hosts</code> – Number of hosts supported by the NIC • <code>first_addr</code> – The MAC address of the first port on the first host for the first partition on that port • <code>host_addr[i]</code> – base MAC address of i^{th} host ($0 \leq i \leq \text{num_hosts}-1$) • <code>bmc_addr[i]</code> – base MAC address of i^{th} BMC ($0 \leq i \leq \text{num_hosts}-1$) <p>Formulae:</p> <ul style="list-style-type: none"> • $\text{host_addr}[i] = \text{first_addr} + i * \text{num_ports} * (\text{max_parts} + 1)$ • The assignment of MAC address used by i^{th} host on port j for the partition k is out of the scope of this specification. • $\text{bmc_addr}[i] = \text{host_addr}[i] + \text{num_ports} * \text{max_parts}$ • The MAC address used by i^{th} BMC on port j, where $0 \leq i \leq \text{num_hosts}-1$ and $0 \leq j \leq \text{num_ports} - 1$ is $\text{bmc_addr}[i] + j$ 			
<p>Support at least one of the following mechanism for provisioned MC MAC Address retrieval:</p> <ul style="list-style-type: none"> • NC-SI Control/RBT (DMTF DSP0222 1.1 or later compliant) • NC-SI Control/MCTP (DMTF DSP0261 1.2 compliant) <p>Note: This capability is planned to be included in revision 1.2 of the DSP0222 NC-SI specification.</p> <p>For DMTF DSP0222 1.1 compliant OCP NIC 3.0 implementations, MC MAC address retrieval shall be supported using NC-SI OEM commands. An OCP NIC 3.0 implementation, that is compliant with DMTF DSP0222 that defines standard NC-SI commands for MC MAC address retrieval, shall support those NC-SI commands.</p>	Required	Required	Optional

4.4 Temperature Reporting

An OCP NIC 3.0 implementation can have several silicon components including one or more ASICs implementing NIC functions and one or more transceiver modules providing physical network media connectivity. For the system management, it is important that temperatures of these components can be retrieved over sideband interfaces.

The temperature reporting interface shall be accessible in Aux Power Mode (S5), and Main Power Mode (S0). ~~Table 46~~Table 52 summarizes temperature reporting requirements. These requirements improve the system thermal management and allow the baseboard management device to access key component temperatures on an OCP NIC 3.0 card. When the temperature reporting function is implemented, it is required that the temperature reporting accuracy is within $\pm 3^{\circ}\text{C}$.

Table ~~46~~52: Temperature Reporting Requirements

Requirement	RBT+MCTP Type	RBT Type	MCTP Type
Component Temperature Reporting for a component with TDP $\geq 8\text{W}$ 5 W	Required	Required	Required
Component Temperature Reporting for a component with TDP $< 8\text{W}$ 5 W	Recommended	Recommended	Recommended
When the temperature sensor reporting function is implemented, the OCP NIC 3.0 card shall support PLDM for Platform Monitoring and Control (DSP0248 1.1 -compliant) for temperature reporting.	Required	Required	Required
When the temperature sensor reporting function is implemented, the OCP NIC 3.0 card shall report upper-warning, upper-critical, and upper-fatal thresholds for PLDM numeric sensors. Note: Refer to DSP0248 For definitions of the upper warning, upper critical, and upper fatal thresholds, refer to DSP0248 1.1 .	Required	Required	Required
When the temperature reporting function is implemented using PLDM numeric sensors, the temperature tolerance shall be reported as part of the sensor Platform Descriptor Record (PDR) format .	Required	Required	Required
Support for NIC self-shutdown. The purpose of this the self-shutdown feature is to “self-protect” the NIC ASIC from permanent damage due to high operating temperatures experienced by the NIC . The NIC can may accomplish this by reducing the power consumed by the device ASIC. A BMC may continuously monitor the NIC ASIC temperature and shutdown the NIC ASIC as soon as the temperature reaches a threshold value. There may be scenarios and implementations where the OCP NIC ASIC may be required to self-shutdown without	Optional	Optional	Optional

<p>depending on an external entity like the BMC. For those scenarios and implementations, the self-shutdown feature is a final effort in preventing permanent damage to the NIC ASIC at the expense of potential data loss.</p> <p>The <u>if the self-shutdown feature is implemented, the NIC ASIC shall monitor its temperature and shut-down itself as soon as the self-shutdown threshold value is reached. The value of the self-shutdown threshold is implementation specific. It is recommended that the self-shutdown threshold value is higher than the maximum junction temperature of the ASIC implementing the NIC function. It is also recommended that the self-shutdown threshold and this value is between the critical and fatal temperature thresholds of the ASIC. The self-shutdown feature is a final effort in preventing permanent card damage at the expense of potential data loss.</u></p> <p>If this <u>the self-shutdown</u> feature is implemented, care shall be taken to ensure that the board power down state is latched and that the board does not autonomously resume normal operation.</p> <p>Note: It is assumed that a system management function will prevent a component from reaching its fatal threshold temperature.</p> <p>The OCP NIC 3.0 card does not need to know the reason for the <u>NIC ASIC</u> self-shutdown threshold crossing (e.g. fan failure). After <u>entering the NIC ASIC enters</u> the self-shutdown state, the OCP NIC 3.0 card is may not <u>required to</u> be operational. This might cause the system with the OCP NIC 3.0 card to become unreachable via the NIC.</p> <p>In order to recover the NIC from ASIC from the self-shutdown state, the OCP NIC 3.0 card shall go through the NIC ID Mode state as described in Section <u>3.8.13.9.1</u>.</p> <p><u>If the self-shutdown feature is implemented, the implementation shall provide a mechanism to enable/disable the feature.</u></p> <p><u>Note: It is assumed that a system management function will prevent a component from reaching its fatal threshold temperature.</u></p>			
---	--	--	--

Commented [MC10]: The self-shutdown should be 5C or more higher than than Tjmax.

4.5 Power Consumption Reporting

An OCP NIC 3.0 implementation may be able to report the power consumed at the board level. It is important for the system management that the information about the power consumption can be retrieved over sideband interfaces. [Table 47](#)~~Table 53~~ summarizes power consumption reporting requirements.

[Table 47](#)~~53~~: Power Consumption Reporting Requirements

Requirement	RBT+MCTP Type	RBT Type	MCTP Type
Board Only Estimated Power Consumption Reporting. The value of this field is encoded into the FRU EEPROM contents. This field reports the board max power consumption value without transceivers plugged into the line side receptacles.	Required	Required	Required
Pluggable Transceiver Module Power Reporting. The pluggable transceivers plugged into the line side receptacles shall be inventoried (via an EEPROM query) and the total module power consumption is Power Class of the module shall be reported .	Required	Required	Required
Board Runtime Power Consumption Reporting. This value shall be optionally reported over the management binding interface. The runtime power value shall report the card edge power.	Optional	Optional	Optional
PLDM for Platform Monitoring and Control (DSP0248 1-1 compliant) shall be used for transceiver and component board power consumption reporting.	Required	Required	Required

4.6 Pluggable Transceiver Module Status and Temperature Reporting

A pluggable transceiver module is a compact, hot-pluggable transceiver used to connect the OCP 3.0 NIC to an external physical medium. It is important for proper system operation to know the presence and temperature of pluggable transceiver modules. [Table 48](#)~~Table 54~~ summarizes pluggable module status reporting requirements.

[Table 48](#)~~54~~: Pluggable Module Status Reporting Requirements

Requirement	RBT+MCTP Type	RBT Type	MCTP Type
Pluggable Transceiver modules Presence Status and Temperature Reporting	Required	Required	Required
PLDM for Platform Monitoring and Control (DSP0248 1-1 compliant) for reporting the pluggable transceiver module presence status and pluggable transceiver module temperature	Required	Required	Required

4.7 Management and Pre-OS Firmware Inventory and Update

An OCP NIC 3.0 implementation can have different types of firmware components for data path, control path, and management path operations. It is desirable that OCP NIC 3.0 implementations support an OS-independent mechanism for the management firmware update. It is desirable that the management

firmware update does not require a system reboot for the new firmware image to become active. [Table 49](#)~~Table 55~~ summarizes the firmware inventory and update requirements.

Table ~~4955~~: Management and Pre-OS Firmware Inventory and Update Requirements

Requirement	RBT+MCTP Type	RBT Type	MCTP Type
Network boot in UEFI driver (supporting both IPv4 and IPv6 addressing for network boot)	Required	Required	Required
UEFI secure boot for UEFI drivers	Required	Required	Required
UEFI Firmware Management Protocol (FMP)	Required	Required	Required
PLDM for Firmware Update (DSP0267 1.0 -compliant)	Required	Recommended	Required

4.7.1 Secure Firmware

It is highly recommended that an OCP NIC 3.0 card supports a secure firmware feature. In the future versions of the OCP NIC 3.0 specification, the secure firmware feature is intended to be required. When the secure firmware feature is enabled and where export compliance permits, the OCP NIC 3.0 card shall verify firmware components prior to the execution, execute only signed and verified firmware components, and only allow authenticated firmware updates. Where applicable, an OCP NIC 3.0 implementation shall use the guidelines provided in NIST SP 800-193 (~~draft~~) Platform Resiliency Guidelines for the following secure firmware functions:

- Signed Firmware Updates
- Ensure only valid/authenticated firmware updates can be applied. Refer to: NIST 800-193 Section 3.5 Firmware Update Mechanisms, and 4.1.2 Root of Trust for Update (RTU) and Chain of Trust for Update (CTU)
- Ensure authentication mechanisms cannot be bypassed. Refer to NIST 800-193 Section 4.2 Protection.
- Secure Boot
- Only boot trusted/authenticated firmware: NIST 800-193 4.1.3 Root of Trust for Detection (RTD) and Chain of Trust for Detection (CTD), and Section 4.3 Detection
- Recovery mechanism in case of boot failure: NIST 800-193 Section 4.4 Recovery

4.7.2 Firmware Inventory

The OCP NIC 3.0 card shall allow queries to obtain the firmware component versions, device model, and device ID via in-band and out-of-band interfaces without impacting NIC function and performance of said paths.

4.7.3 Firmware Inventory and Update in Multi-Host Environments

A multi-host capable OCP NIC 3.0 card shall gracefully handle concurrent in-band queries from multiple hosts and out-of-band access from the BMC for firmware component versions, device model, and device ID information.

A multi-host capable OCP NIC 3.0 card shall only permit one entity to perform write accesses to NIC firmware at a time, without creating contention.

A multi-host capable OCP NIC 3.0 card shall gracefully handle exceptions when more than one entity attempts to perform concurrent NIC firmware writes.

4.8 NC-SI Package Addressing and Hardware Arbitration Requirements

NC-SI over RBT is implemented via RMII pins between the MC and the OCP NIC 3.0 card. Protocol and implementation details of NC-SI over RBT can be found in the DMTF DSP0222 standard.

4.8.1 NC-SI over RBT Package Addressing

NC-SI over RBT capable OCP NIC 3.0 cards shall use a unique Package ID per ASIC when multiple ASICs share the single NC-SI physical interconnect to ensure there are no addressing conflicts.

Commented [HS11]: Current firmware inventory definition is vague. Need to define what it means in each environment including UEFI, OOB via PLDM, and NC-SI ctrl. Need to define what is the minimum set for firmware inventory.

There is no change in text needed. Firmware inventory information is implementation dependent.

Baseboards use the Slot_ID[1:0] values on the Primary Connector for this identification. The value of Slot_ID[1:0] is determined by the encoding shown in [Table 50Table-56](#). SLOT_ID[1:0] is statically set high or low on the baseboard and is available on the OCP Bay portion of the Primary Connector.

Table 5056: Slot_ID[1:0] to Package ID[2:0] Mapping

Physical Slot (Dec.)	SLOT_ID[1:0]		Package ID[2:0]		
	Pin OCP_A6	Pin OCP_B7	Package ID[2]	Package ID[1]	Package ID[0]
	SLOT_ID1	SLOT_ID0	PhysDev#	SLOT_ID1	SLOT_ID0
Slot 0	0	0	0/1	0	0
Slot 1	0	1	0/1	0	1
Slot 2	1	0	0/1	1	0
Slot 3	1	1	0/1	1	1

Package ID[2:0] is a 3-bit field and is encoded in the NC-SI Channel ID as bits [7:5]. SLOT_ID1 is associated with Package ID[1]. SLOT_ID0 is associated with Package ID[0]. The Package ID[2] value is based on the silicon instance on the same physical OCP NIC 3.0 card. Package ID[2]==0b0 is assigned for physical controller #0. Package ID[2]==0b1 is assigned for physical controller #1. In this case, physical controller #1 on the same card is at an address offset of +0x4. Refer to the specific endpoint device datasheet for details on the Package ID configuration options.

Note: The Package ID[2] field is optionally configurable in the NC-SI specification. If the target silicon hard codes this bit to 0b0, then a card must only implement a single silicon instance to prevent addressing conflicts.

Refer to the DMTF DSP0222 standard for more information on package addressing and Package ID.

4.8.2 Arbitration Ring Connections

For baseboards that implement two or more Primary Connectors, the NC-SI over RBT arbitration ring shall be connected to each other. The arbitration ring shall support operation with one card, or multiple cards installed. [Figure 80Figure-78](#) shows an example connection with dual Primary Connectors.

4.9 SMBus 2.0 Addressing Requirements

The SMBus provides a low speed management bus for the OCP NIC 3.0 card. The FRU EEPROM is directly connected to the OCP NIC 3.0 card edge on this bus and can be read by the baseboard in the ID Mode, Aux Power Mode and Main Power Mode. Network controllers may utilize the SMBus 2.0 interface for MCTP communications. OCP NIC 3.0 does not support MCTP over I²C due to the use of specific SMBus 2.0 addressing. Proper power domain isolation shall be implemented on the NIC.

4.9.1 SMBus Address Map

OCP NIC 3.0 cards shall support [the SMBus Address Resolution Protocol \(ARP\)](#). ~~This to allows for dynamic assignment of slave device addresses each device to be dynamically assigned an addresses for MCTP communication.~~ This method automatically resolves address conflicts and eliminates the need for manual [address configuration of addresses](#). The [SMBus address type type of dynamic addresses](#) can be either ~~a a dynamic-Dynamic and pPersistent aAddress device~~ or a ~~dynamic-Dynamic and volatile-Volatile address-Addressdevice~~. Refer to [the SMBus 2.0 specification](#) and Section 6.11 of DSP0237 [1-1](#) for details on SMBus address assignment.

A ~~system-baseboard~~ implementation may choose to only use fixed addresses for ~~an~~ OCP NIC 3.0 cards ~~on the system~~. The assignment of these fixed addresses is system dependent and ~~is~~ outside the scope of this specification. When fixed addresses are ~~assigned-used to OCP NIC 3.0 card~~, then the OCP NIC 3.0 card shall be a ~~fixed-Fixed~~ and ~~discoverable-Discoverable~~ SMBus device. Refer to ~~the~~ SMBus 2.0 specification for more details.

All predefined SMBus addresses for OCP NIC 3.0 are shown in ~~Table 51~~ ~~Table 57~~. Baseboard and OCP NIC 3.0 card designers must ensure additional devices do not conflict. The addresses shown are in 8-bit format and represent the read/write address pair.

Table ~~5157~~: FRU EEPROM Address Map

Physical Slot (Dec.)	SLOT_ID[1:0]		FRU EEPROM Address				
	Pin OCP_A6	Pin OCP_B7	A2	A1	A0	Binary Address	Hex Address
	SLOT_ID1	SLOT_ID0	SLOT_ID1	SLOT_ID0	Fixed		
Slot 0	0	0	0	0	0	0b1010_000X	0xA0/0xA1
Slot 1	0	1	0	1	0	0b1010_010X	0xA4/0xA5
Slot 2	1	0	1	0	0	0b1010_100X	0xA8/0xA9
Slot 3	1	1	1	1	0	0b1010_110X	0xAC/0xAD

4.10 FRU EEPROM

4.10.1 FRU EEPROM Address, Size and Availability

The FRU EEPROM provided for the baseboard to determine the card type and is directly connected to the SMBus on the card edge. Only one EEPROM is required for a single physical OCP NIC 3.0 card regardless of the PCIe width or number of physical card edge connectors it occupies. The FRU EEPROM is mandatory and shall be connected to the Primary Connector SMBus.

The EEPROM is addressable at the addresses indicated in ~~Table 51~~Table 57. The write/read pair is presented in 8-bit format. The size of EEPROM shall be at least 4Kbits for the base EEPROM map. OCP NIC 3.0 card suppliers may use a larger size EEPROM if needed to store vendor specific information. The FRU EEPROM shall use double byte addressing. The FRU EEPROM shall be write protected for production cards by pulling the EEPROM WP pin high to +3.3V_EDGE. The FRU shall be writable for manufacturing test and during card development by pulling the EEPROM WP pin low to ground.

The FRU EEPROM is readable in all three power states (ID mode, AUX(S5) mode, and MAIN(S0) mode).

4.10.2 FRU EEPROM Content Requirements

The FRU EEPROM shall follow the data format specified in [Section 17 of the IPMI Platform Management FRU Information Storage Definition v1.0 Document Revision 1.3 specification](#). ~~For OCP NIC 3.0, the FRU Information Device shall, at a minimum, contain the Common Header, Both the Product Board Info Area, and Board Product Info Area records and a MultiRecord Area for storing the OEM record. shall-These fields shall~~ be populated in the FRU EEPROM. Where applicable, fields common to the [Product Board Info](#) and [Board Product Info](#) records shall be populated with the same values so they are consistent.

The OEM record 0xC0 is used to store specific records for the OCP NIC 3.0 [and is stored in the MultiRecord area of the FRU layout](#). For an OCP NIC 3.0 card, the FRU EEPROM OEM record content based on the format defined in ~~Table 52~~Table 58 shall be populated.

Note: ~~Table 52~~Table 58 only shows a portion of the OEM record. The complete record includes a Common Header and valid record checksum as defined in the IPMI Platform Management FRU Information Storage Definition specification.

Table ~~5258~~: FRU EEPROM Record – OEM Record 0xC0, Offset 0x00

Offset	Length	Description
0	3	Manufacturer ID.

		For OCP NIC 3.0 compliant cards, the value of this field shall be set to the OCP IANA assigned number. This value is 0x7FA600, <u>Least Significant</u> byte first. (42623 in decimal)
3	1	OCP NIC 3.0 FRU OEM Record Version. For OCP NIC 3.0 cards compliant to this specification, the value of this field shall be set to 0x01.
4	1	Card Max power (in Watts) in MAIN (S0) mode. The encoded value is the calculated max power of the OCP NIC 3.0 card in the Main Power (S0) mode only and does not include the consumed power by transceivers plugged into the line side receptacle(s). 0x00 – 0xFE – Card power rounded up to the nearest Watt for fractional values. 0xFF – Unknown
5	1	Card Max power (in Watts) in AUX (S5) mode. The encoded value is the calculated max power of the OCP NIC 3.0 card in the Aux Power (S5) mode only and does not include the consumed power by transceivers plugged into the line side receptacle(s). 0x00 – 0xFE – Card power rounded up to the nearest Watt for fractional values. 0xFF – Unknown
6	1	Hot Aisle Card Cooling Tier. The encoded value reports the OCP NIC 3.0 Card Hot Card Cooling Tier as defined in Section 6.6.1. 0x00 – RSVD 0x01 – Hot Aisle Cooling Tier 1 0x02 – Hot Aisle Cooling Tier 2 0x03 – Hot Aisle Cooling Tier 3 0x04 – Hot Aisle Cooling Tier 4 0x05 – Hot Aisle Cooling Tier 5 0x06 – Hot Aisle Cooling Tier 6 0x07 – Hot Aisle Cooling Tier 7 0x08 – Hot Aisle Cooling Tier 8 0x09 – Hot Aisle Cooling Tier 9 0x0A – Hot Aisle Cooling Tier 10 0x0B – Hot Aisle Cooling Tier 11 0x0C – Hot Aisle Cooling Tier 12 0x0D – 0xFE – Reserved 0xFF – Unknown
7	1	Cold Aisle Card Cooling Tier. The encoded value reports the OCP NIC 3.0 Card Cold Aisle Cooling Tier as defined in Section 6.6.2. 0x00 – RSVD 0x01 – Cold Aisle Cooling Tier 1 0x02 – Cold Aisle Cooling Tier 2 0x03 – Cold Aisle Cooling Tier 3 0x04 – Cold Aisle Cooling Tier 4 0x05 – Cold Aisle Cooling Tier 5 0x06 – Cold Aisle Cooling Tier 6 0x07 – Cold Aisle Cooling Tier 7

		<p>0x08 – Cold Aisle Cooling Tier 8 0x09 – Cold Aisle Cooling Tier 9 0x0A – Cold Aisle Cooling Tier 10 0x0B – Cold Aisle Cooling Tier 11 0x0C – Cold Aisle Cooling Tier 12 0x0D – 0xFE – Reserved 0xFF – Unknown</p>
8	1	<p>Card active/passive cooling. This byte defines if the card has passive cooling (there is no fan on the card) or active cooling (a fan is located on the card). 0x00 – Passive Cooling 0x01 – Active Cooling 0x02 – 0xFE – Reserved 0xFF – Unknown</p>
9	2	<p>Hot aisle standby airflow requirement. The encoded value represents the amount of airflow, in LFM, required to cool the card in AUX (S5) mode while operating in a hot aisle environment. Refer to Section 6 for more information about the thermal and environmental requirements. Byte 9 is the LS-least significant byte, byte 10 is the MS-most significant byte. 0x0000-0xFFFFE – LFM required for cooling card in Hot Aisle Operation. 0xFFFFF – Unknown.</p>
11	2	<p>Cold aisle standby airflow requirement. The encoded value represents the amount of airflow, in LFM, required to cool the card in AUX (S5) mode while operating in a cold aisle environment. Refer to Section 6 for more information about the thermal and environmental requirements. Byte 11 is the LS-least significant byte, byte 12 is the MS-most significant byte. 0x0000-0xFFFFE – LFM required for cooling card in Cold Aisle Operation. 0xFFFFF – Unknown.</p>
13	1	<p>UART Configuration 1 – Secondary Connector. This byte denotes the UART configuration 1. A value 0x00 means no serial connection is implemented on the Secondary Connector card edge. Bits [2:0] denotes the UART baud rate per the encoding table below. If implemented, the encoded field value defines the default baud rate of the OCP NIC 3.0 card serial port. 0b000 – No serial connection 0b001 – 115200 baud 0b010 – 57600 baud 0b011 – 38400 baud 0b100 – 19200 baud 0b101 – 9600 baud 0b110 – 4800 baud 0b111 – 2400 baud Bits [4:3] denotes the number of data bits. 0b00 – No serial connection 0b01 – 7 data bits</p>

		<p>0b10 – 8 data bits 0b11 – Reserved</p> <p>Bits [7:5] denotes the parity bit character.</p> <p>0b000 – No serial connection 0b001 – None (N) 0b010 – Odd (O) 0b011 – Even (E) 0b100 – Mark (M) 0b101 – Space (S) 0b110 – Reserved 0b111 – Reserved</p>
14	1	<p>UART Configuration 2 – Secondary Connector.</p> <p>This byte denotes the UART configuration 2. A value 0x00 means no serial connection is implemented on the Secondary Connector card edge.</p> <p>Bits [1:0] denotes the number of stop bits.</p> <p>0b00 – No serial connection 0b01 – 1 stop bit 0b10 – 1.5 stop bits 0b11 – 2 stop bits</p> <p>Bits [3:2] denotes the flow control method.</p> <p>0b00 – No serial connection 0b01 – Software handshaking 0b10 – No handshaking 0b11 – Reserved</p> <p>Bits [7:4] are reserved and shall be encoded to a value of 0b0000.</p>
15	1	<p>USB Present – Primary Connector.</p> <p>This byte denotes a USB 2.0 connection is implemented on the Primary Connector card edge.</p> <p>0x00 – No USB 2.0 is present or is not implemented on the card edge 0x01 – A USB 2.0 connection is implemented on the card edge.</p>
16	1	<p>Manageability Type.</p> <p>This byte denotes the card manageability type and interface used.</p> <p>0x00 – No manageability 0x01 – RBT Type 0x02 – MCTP Type 0x03 – RBT + MCTP Type 0x04-0x0FF – Reserved for future use</p>
17:30	14	<p>Reserved for future use.</p> <p>Set each byte to 0xFF for this version of the specification.</p>
31	1	<p>Number of physical controllers (N).</p> <p>This byte denotes the number of physical controllers on the OCP NIC 3.0 card. If N=0, no controllers exist on this OCP NIC 3.0 card and this is the last byte in the FRU OEM Record.</p> <p>If $N \geq 1$, then the controller UUID records below shall be included for each controller N. OCP NIC 3.0 cards may implement up to six physical controllers (N=6) for a Large Form Factor LFF card.</p>
32:47	16	<p>Controller 1 UUID (if applicable).</p>

		This field reports the Controller 1 Universally Unique Device Identifier (UUID) and is used to aid in the dynamic slave address assignment over the SMBus Address Resolution Protocol. This field shall list the MS-most significant Byte-by-byte First-first (to align the FRU order to the reported UUID order on the SMBus). This field is populated with the UUID for Controller 1.
48:63	16	Controller 2 UUID (if applicable).
64:79	16	Controller 3 UUID (if applicable).
80:95	16	Controller 4 UUID (if applicable).
96:111	16	Controller 5 UUID (if applicable).
112:127	16	Controller 6 UUID (if applicable).

4.10.3 FRU Template

A FRU template is provided as a baseline implementation example. This FRU template contains the IPMI Platform Management FRU Information Storage Definition ~~v1-2~~ Product Info, Board Info records as well as the OEM record for OCP NIC 3.0.

The FRU template file may be downloaded from the OCP NIC 3.0 Wiki site:
<http://www.opencompute.org/wiki/Server/Mezz>.

5 Routing Guidelines and Signal Integrity Considerations

5.1 NC-SI ~~Over-over~~ RBT

For the purposes of this specification, the OCP NIC 3.0 card NC-SI signals min and max electrical trace length shall be between 2 inches and 4 inches on standard FR4 material. Additional trace length may be achieved with the use of lower loss material. This selection is left up to the card vendor when considering board materials. The traces shall be implemented as 50 Ohm \pm 10% impedance controlled nets. This requirement applies to both the ~~small-SFF~~ and ~~large form factor~~LFF OCP NIC 3.0 cards.

NC-SI ~~o~~Over RBT isolation buffers are required on the system board. The requirements for additional add-in card loading are reduced. OCP NIC 3.0 card and baseboard designers are encouraged to follow the guidelines defined in the RMII and NC-SI specifications for physical routing. Refer to Section ~~3.4.43-4.4~~ and the DSP0222 specification for example interconnect topologies.

5.1.1 Timing Budget

TBD – need to align on topologies.

5.2 SMBus 2.0

This section is a placeholder for SMBus 2.0 related routing guidelines and SI considerations. The OCP NIC 3.0 subgroup intends to define the bus operational speed range, capacitive loading, and range of pull up resistance values. Doing so allows the baseboard suppliers to design a SMBus interface that is compatible with OCP NIC 3.0 products.

Commented [TN12]: The OCP NIC 3.0 SI Workgroup is currently contributing to this section. The contents of this section are a work in progress and is expected to be complete for version 0v90.

Commented [TN13]: - Refer to the SMBus specification for details / speed / voltage range.

-Max capacitance and location of pull ups.

- Refer to SMBus specification as appropriate. Differences/implementation specific items for OCP NIC 3.0 are called out here.

5.3 PCIe

OCP NIC 3.0 card suppliers shall follow the PCIe routing specifications. Refer to the PCIe CEM and PCIe Base specifications for end-to-end channel signal integrity considerations.

5.3.1 Background

5.3.25.3.1 Channel Requirements

The OCP NIC 3.0 PCIe channel requirements align with the electrical budget and constraints as detailed in the PCI Express® CEM 4.0 Rev 1.0 and PCI Express Base Specification Rev 4.0. Exceptions or clarifications to the referenced specifications are noted in the sections below.

5.3.2.15.3.1.1 REFCLK requirements

REFCLK requirements are detailed in the PCI Express CEM 4.0 Rev 1.0 Section 2.1.

5.3.2.25.3.1.2 Add-in Card Electrical Budgets

This section defines the OCP NIC 3.0 card channel budget from the gold finger edge to the end point silicon. The values listed below are shown for reference and mirrors that of the PCIe CEM 4.0 specification.

Table 5359: PCIe Electrical Budgets

Parameter	PCIe CEM 4.0 Rev 1.0 Specification Section
AC coupling capacitors	Section 4.7.1
Insertion Loss Values (Voltage Transfer Function)	Section 4.7.2 and Appendix A. Section 4.7.10 for 16 GT/s
Jitter Values	Section 4.7.3 for 8 GT/s and 16 GT/s. Also refer to the PCIe Base Specification Section 8.3.5
Crosstalk	Section 4.7.4
Lane-to-lane skew (S_A) for Add-in cards	Section 4.7.5
Transmitter Equalization	Section 4.7.6 and PCIe Base Spec Chapter 9
Skew within a differential pair	Section 4.7.7
Differential data trace impedance	Section 4.7.8
Differential data trace propagation delay	Section 4.7.9

Commented [TN14]: Align per CEM.

Commented [NT15]: Need to scrub.

5.3.2.35.3.1.3 Baseboard Channel Budget

The baseboard channel budget directly follows the PCI Express CEM 4.0 Rev 1.0 specification. Details of the budget are outside of the scope of this specification.

5.3.2.45.3.1.4 SFF-TA-1002 Connector Channel Budget

Reference the SFF-TA-1002 Revision 1.1 or later.

5.3.2.55.3.1.5 Differential Impedance (Informative)

For PCIe transmit and receive differential pairs, the target impedance is 85 Ohms \pm 10%.

For the PCIe REFCLKs, the target impedance is 100 Ohms \pm 10%.

5.3.35.3.2 Test Fixtures

Test Fixtures are designed using the PCIe CEM 4.0 CLB and CBB. The fixtures host interface has been modified to the OCP connector standard and there are two version of the fixtures, one for Gen 3 PCIe and one for Gen 4 PCIe. Careful attention has been placed on these fixtures to help insure that standard test equipment automation should work without significant modification.

Commented [NT16]: Need higher quality photos of the test fixtures for 0v90.

Table 5460: PCIe Test Fixtures for OCP NIC 3.0

Test Fixture	PCIe Generation	PCB Material
Load Board	Gen 3	TU863
	Gen 4	TU883
Base Board	Gen 3	TU863
	Gen 4	TBD (+vISI board)

5.3.3.15.3.2.1 Load Board

Figure 10296: PCIe Load Board Test Fixture for OCP NIC 3.0 SFF

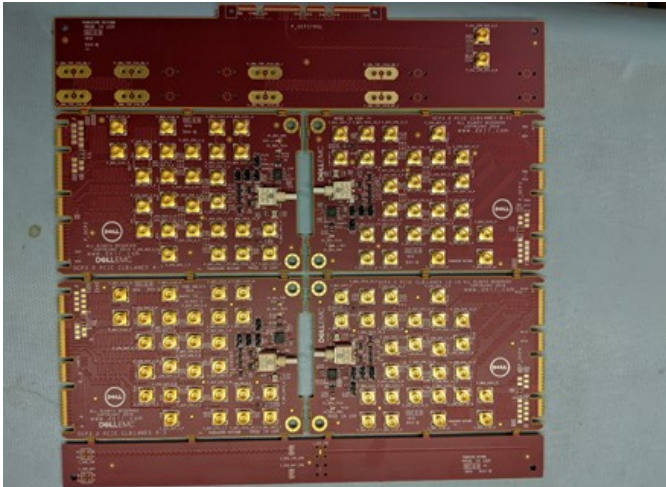

[5.3.3.25.3.2.2](#) Baseboard

Figure [10397](#): PCIe Base Board Test Fixture for OCP NIC 3.0 SFF

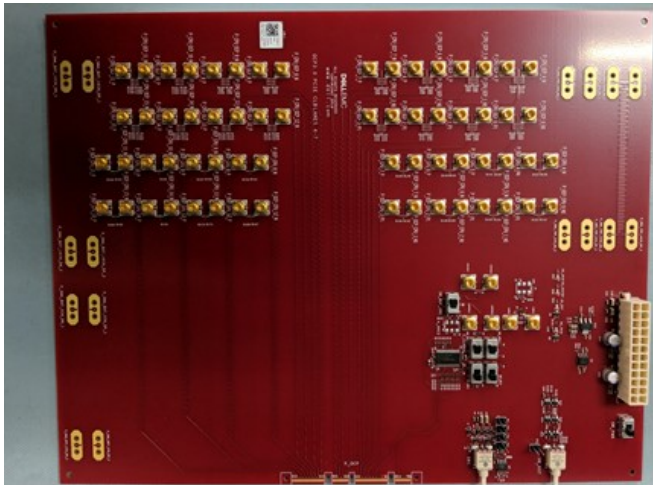

[5.3.45.3.3](#) Test Methodology

The OCP NIC 3.0 ~~form factor~~ is compliant to the applicable PCIe specifications. The electrical interface may be tested against the PCI Express® Architecture PHY Test Specification Revision 4.0, providing that the appropriate test fixtures from Section [5.3.25.3.3](#) are used.

[5.3.4.15.3.3.1](#) Test Setup

This section is a work-in-progress by the OCP NIC 3.0 SI Subgroup. The following information will be added in a future document release:

- Description of the OCP NIC 3.0 CLB and CBB test figure for use in the PCIe Architecture PHY Test Specifications.
- A user guide is in development through UNH.

6 Thermal and Environmental

6.1 Airflow Direction

The OCP NIC 3.0 card is designed to operate in either of two different airflow directions which are referred to as Hot Aisle and Cold Aisle. In both Hot Aisle and Cold Aisle configurations all airflow is directed over the topside of the card. Component placement must assume that there will be no airflow on the bottom side of the card. The local approach air temperature and velocity to the card is dependent on the capability of the system adopting OCP NIC 3.0 card. These parameters may be impacted by the operational altitude and relative humidity in Hot Aisle or Cold Aisle configurations. Design boundary conditions for Hot Aisle and Cold Aisle cooling are included below in Sections 6.1.1 and 6.1.2 respectively.

The two airflow directions of the Hot and Cold Aisle cases should not result in multiple thermal solutions to separately satisfy the varying thermal boundary conditions. Ideally, any specific OCP NIC 3.0 card design should function in systems with either Hot Aisle or Cold Aisle cooling. Thermal analysis in support of this specification have shown the Hot Aisle configuration to be more challenging than Cold Aisle but card vendors should make that determination for each card that is developed.

6.1.1 Hot Aisle Cooling

The airflow in typical server systems will approach from the card edge or heatsink side of the card. This airflow direction is referred to as Hot Aisle cooling and is illustrated below in [Figure 104](#)[Figure 98](#). The term Hot Aisle refers to the card being located at the rear of the system where the local inlet airflow is preheated by the upstream system components (e.g. HDD, CPU, DIMM, etc.).

[Figure 104](#)[98](#): Airflow Direction for Hot Aisle Cooling (SFF and LFF)

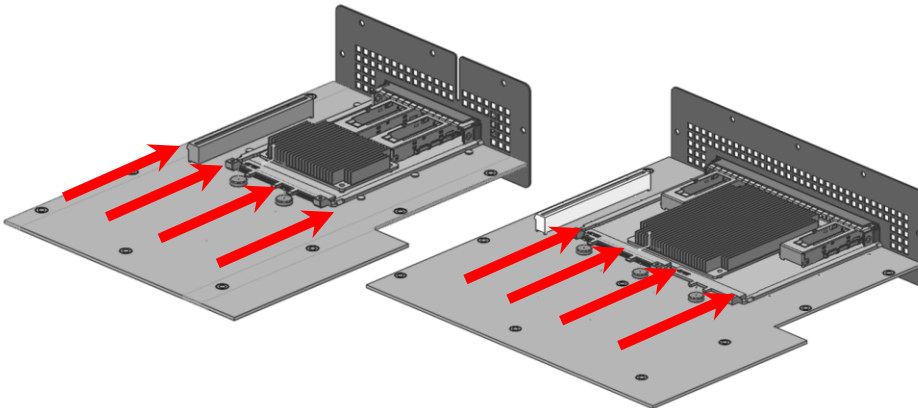

The boundary conditions for Hot Aisle cooling are shown below in [Table 55](#)[Table 61](#) and [Table 56](#)[Table 62](#). The low temperature is listed at 5°C and assumes fresh air could be ducted to the back of the system from the front. More typically the inlet temperature to the OCP NIC 3.0 card will be in the same range as PCIe cards located at the back of the system (55°C local inlet temperature). Depending on the system design, power density, and airflow the inlet temperature to the OCP NIC 3.0 card may be as high as 60°C or 65°C. The airflow velocities listed in [Table 56](#)[Table 62](#) represent the airflow velocities typical in

mainstream servers. Higher airflow velocities are available within the Hot Aisle cooling tiers listed in [Table 61](#) but card designers must be sure to understand the system level implications of such high card LFM requirements.

Table 5561: Hot Aisle Air Temperature Boundary Conditions

	Low	Typical	High	Max
Local Inlet air temperature	5°C (system inlet)	55°C	60°C	65°C

Table 5662: Hot Aisle Airflow Boundary Conditions

	Low	Typical	High	Max
Local inlet air velocity	50 LFM	100-200 LFM	300 LFM	System Dependent

6.1.2 Cold Aisle Cooling

When installed in the front of a server the airflow will approach from the I/O connector (e.g. SFP, QSFP or RJ-45) side of the card. This airflow direction is referred to as Cold Aisle cooling and is illustrated below in [Figure 105](#). The term Cold Aisle refers to the card being located at the front of the system where the local inlet airflow is assumed to be the same temperature as the system inlet airflow.

Figure 10599: Airflow Direction for Cold Aisle Cooling (SFF and LFF)

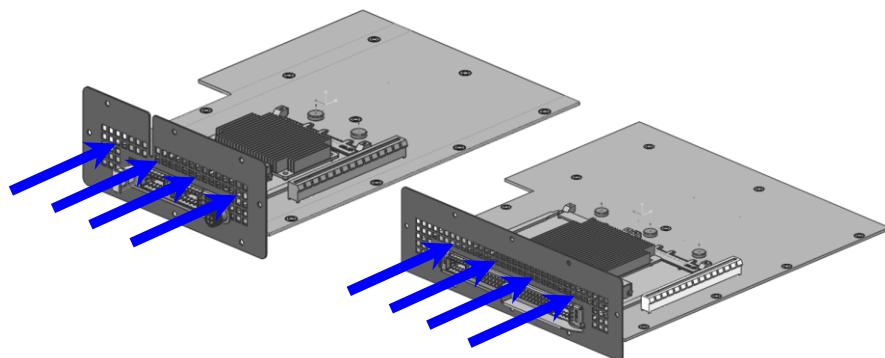

The boundary conditions for Cold Aisle cooling are shown below in [Table 57](#) and [Table 58](#). The temperature values listed in [Table 57](#) assume the inlet temperature to the OCP NIC 3.0 card to be the same as the system inlet. The low, typical, high, and max temperatures listed align with the ASHRAE A1, A2, A3, and A4 environmental classes. Depending on the system, the supported ASHRAE class may limit the maximum temperature to the OCP 3.0 NIC card. However, for more broad industry support, cards should be designed to the upper end of the ASHRAE classes (i.e. A4).

Table 5763: Cold Aisle Air Temperature Boundary Conditions

	Low	Typical	High	Max
Local Inlet Air Temperature	5°C	25-35°C ASHRAE A1/A2	40°C ASHRAE A3	45°C ASHRAE A4

Table 5864: Cold Aisle Airflow Boundary Conditions

Local Inlet Air Velocity	Low	Typical	High	Max
	50 LFM	100 LFM	200 LFM	System Dependent

6.2 Thermal Design Guidelines

The information in this section is intended to serve as a quick reference guide for OCP NIC 3.0 designers early in the design process. The information should be used as a reference for upfront thermal design and feasibility and should not replace detailed card thermal design analysis. The actual cooling capability of the card shall be defined based on the testing with the OCP NIC 3.0 thermal test fixture as defined in Section 6.4.

6.2.1 SFF Card ASIC Cooling – Hot Aisle

The ASIC or controller chip is typically the highest power component on the card. Thus, as OCP NIC 3.0 cards are developed it is important to understand the ASIC cooling capability. Figure 106Figure 100 below provides an estimate of the maximum ASIC power that can be supported as a function of the local inlet velocity for the SFF card in a hot aisle cooling configuration. Each curve in Figure 106Figure 100 represents a different local inlet air temperature from 45°C to 65°C.

Figure 106Figure 100: ASIC Supportable Power for Hot Aisle Cooling – SFF

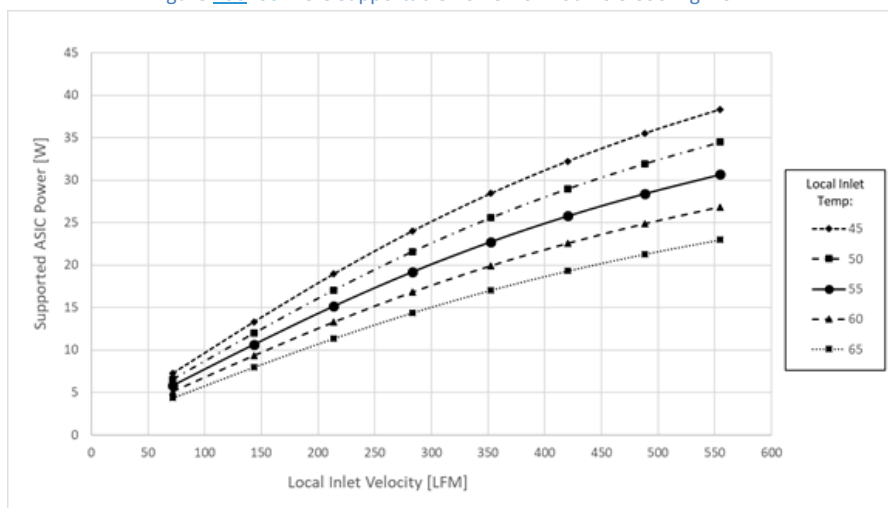

The curves shown in Figure 106Figure 100 were obtained using CFD analysis of a reference OCP NIC 3.0 SFF card. The reference card has a 20 mm x 20 mm ASIC with two QSFP connectors. Figure 107Figure 101 shows a comparison of the 3D CAD and CFD model geometry for the reference OCP NIC 3.0 card. Additional card geometry parameters and boundary conditions used in the reference CFD analysis are summarized in Table 59Table 65. The OCP NIC 3.0 simulation was conducted within a virtual version of the test fixture defined in Section 6.4.

Figure [107494](#): OCP NIC 3.0 SFF Reference Design and CFD Geometry

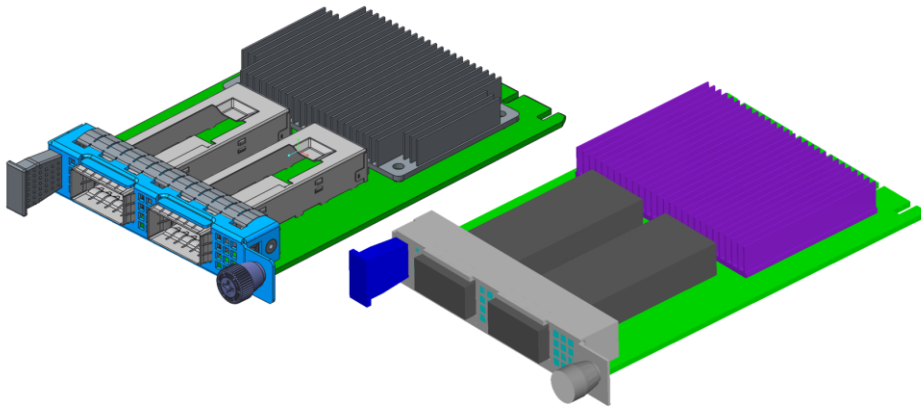

Table [5965](#): Reference OCP NIC 3.0 SFF Card Geometry

OCP NIC 3.0 Form Factor	SFF Card
Heatsink Width	65 mm
Heatsink Length	45 mm
Heatsink Height	9.24 mm
Heatsink Base Thickness	1.5 mm
Fin Count/Thickness	28/0.5 mm
Heatsink Material	Extruded Aluminum
ASIC Width	20
ASIC Length	20
ASIC Height	2.26
ASIC Theta-JC	0.17 C/W
ASIC Theta-JB	10 C/W
OCP PCB In-Plane Conductivity	34 W/mK
OCP PCB Normal Conductivity	0.33 W/mK
ASIC Max T-case	95°C
OCP NIC 3.0 I/O Connectors	Two QSFP @ 3.5 W each

An increase in the supported ASIC power or a decrease in the required airflow velocity may be achieved through heatsink size and material changes. For example, a larger heatsink or a heatsink made out of copper could improve ASIC cooling and effectively shift up the supportable power curves shown in [Figure 106Figure 100](#).

It is important to point out that the curves shown in [Figure 106Figure 100](#) represent only the maximum ASIC power that can be supported vs. the supplied inlet velocity. Other heat loads on the card may require airflow velocities above and beyond that required to cool the ASIC. SFP or QSFP optical transceivers located downstream of the ASIC will in many cases pose a greater cooling challenge than

the ASIC cooling. Cooling the optical transceivers becomes even more difficult as the ASIC power is increased due to additional preheating of the air as it moves through the ASIC heatsink. OCP NIC 3.0 designers must consider all heat sources early in the design process to ensure the card thermal solution is sufficient for the feature set.

Card designers must also consider the airflow capability of the server systems that the cards are targeted for use within. Figure 108 below shows the SFF ASIC supportable power curves with an overlay of three server airflow capability ranges. Designers must ensure that their thermal solutions and resulting card airflow requirements fall within the range of supportable system airflow velocity. Cards that are under-designed (e.g. require airflow greater than the system capability) will have thermal issues when deployed into the server system. Card designers are advised to work closely with system vendors to ensure they target the appropriate airflow and temperature boundary conditions.

Figure 108: Server System Airflow Capability – SFF Card Hot Aisle Cooling

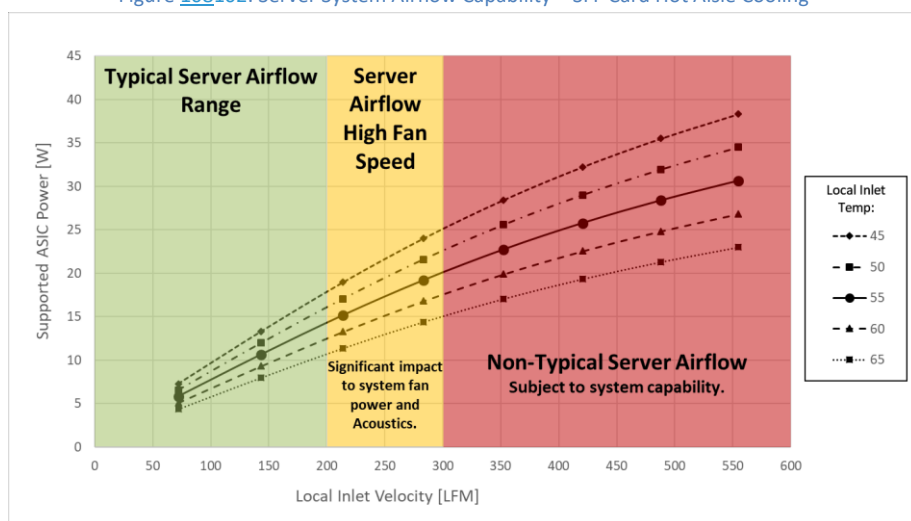

6.2.2 LFF Card ASIC Cooling – Hot Aisle

Figure 109 below provides an estimate of the maximum ASIC power that can be supported as a function of the local inlet velocity for the LFF card in a hot aisle cooling configuration. Each curve in Figure 109 represents a different local inlet air temperature from 45°C to 65°C.

Figure 109: ASIC Supportable Power for Hot Aisle Cooling – LFF Card

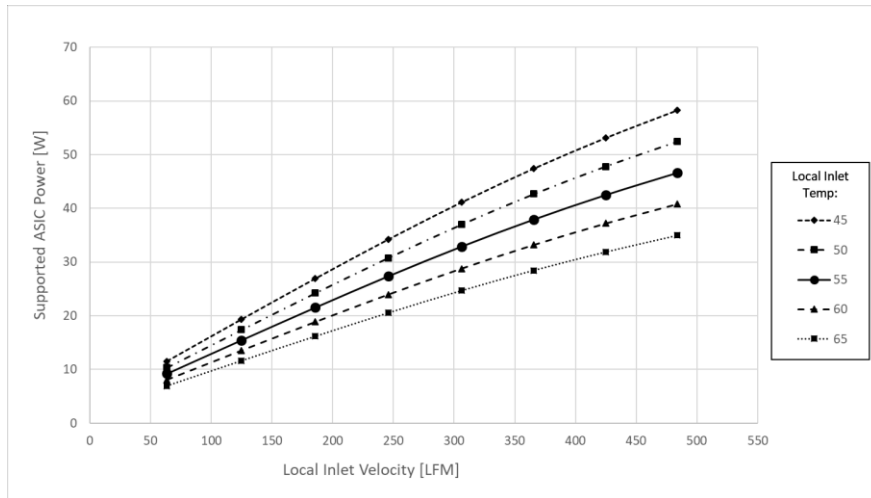

The curves shown in Figure 109 were obtained using CFD analysis of the reference OCP NIC 3.0 LFF card. The reference card has a 45 mm x 45 mm ASIC with two QSFP connectors. Additional card geometry parameters and boundary conditions used in the reference CFD analysis are summarized in Table 60. Figure 110 shows a comparison of the 3D CAD and CFD model geometry for the reference OCP NIC 3.0 card.

Figure 110: OCP NIC 3.0 LFF Reference Design and CFD Geometry

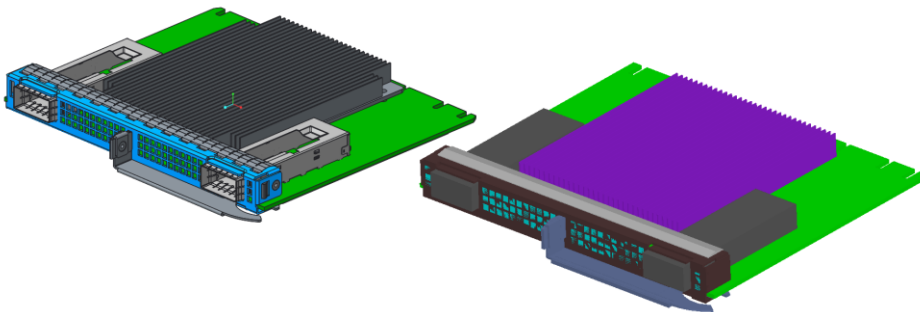

Table ~~6066~~: Reference OCP NIC 3.0 LFF Card Geometry

OCP NIC 3.0 Form Factor	LFF Card
Heatsink Width	75 mm
Heatsink Length	85 mm
Heatsink Height	9.3 mm
Heatsink Base Thickness	1.5 mm
Fin Count/Thickness	33/0.5 mm
Heatsink Material	Extruded Aluminum
ASIC Width	45
ASIC Length	45
ASIC Height	2.13
ASIC Theta-JC	0.17 C/W
ASIC Theta-JB	10 C/W
OCP PCB In-Plane Conductivity	34 W/mK
OCP PCB Normal Conductivity	0.33 W/mK
ASIC T-case Max	95°C
OCP NIC 3.0 I/O Connectors	Two QSFP @ 3.5_W each

It is important to note that the supportable power for the LFF card is considerably higher than for the SFF card due to the increased size of the ASIC heatsink. In addition, optics module cooling on the LFF card will also be considerably improved due to the arrangement of the optics in parallel to the ASIC heatsink rather than in series. These thermal advantages are key drivers for the LFF card geometry. The OCP NIC 3.0 simulation was conducted within a virtual version of the LFF card test fixture defined in Section 6.4.

[Figure 111](#)~~Figure 105~~ below shows the LFF ASIC supportable power curves with an overlay of three server airflow capability ranges. Designers must ensure that their thermal solutions and resulting card airflow requirements fall within the range of supportable system airflow velocity. Cards that are under-designed (e.g. require airflow greater than the system capability) will have thermal issues when deployed into the server system. Card designers are advised to work closely with system vendors to ensure they target the appropriate airflow and temperature boundary conditions.

Figure 111405: Server System Airflow Capability – LFF Card Hot Aisle Cooling

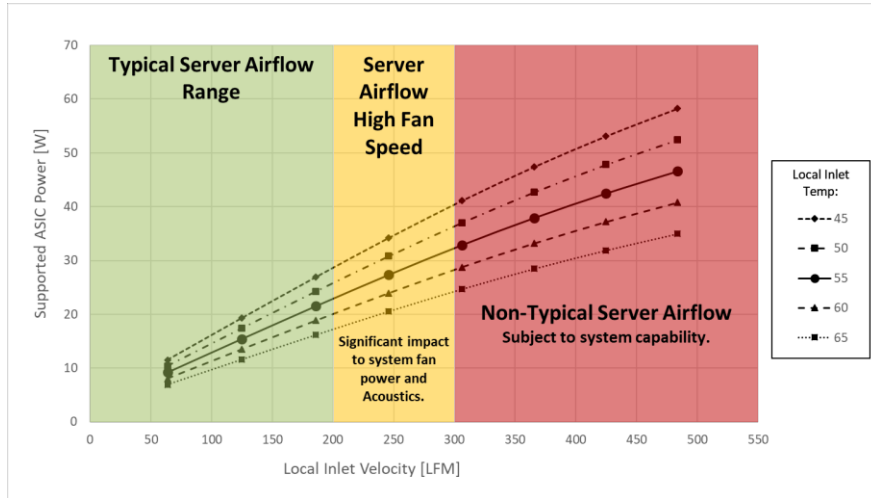

6.2.3 SFF Card ASIC Cooling – Cold Aisle

Compared to the Hot Aisle cooling configuration, there are several key differences for Cold Aisle ASIC cooling. With Cold Aisle cooling the airflow is pulled from the I/O connector side of the card. The I/O connectors and faceplate venting may affect the airflow through the ASIC heatsink. The I/O connectors may also preheat the airflow by some amount. In a Cold Aisle cooling configuration, other parallel airflow paths may result in less airflow passing over and through the OCP NIC 3.0 card compared to the Hot Aisle.

The ASIC cooling analysis for the SFF Card in the Cold Aisle configuration was conducted utilizing the same geometry and boundary conditions described in [Figure 107](#)[Figure 101](#) and [Table 59](#)[Table 65](#) with airflow moving from I/O connector to ASIC (opposite to the Hot Aisle analysis). [Figure 112](#)[Figure 106](#) below shows the results of this analysis for the Cold Aisle cooling configuration. Each curve in [Figure 112](#)[Figure 106](#) represents a different system inlet air temperature from 25°C to 45°C.

Figure 112106: ASIC Supportable Power for Cold Aisle Cooling – SFF Card

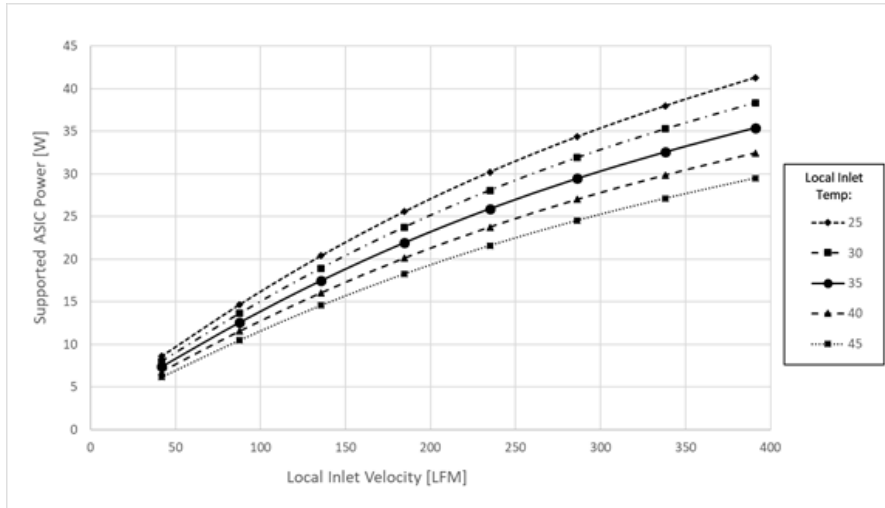

Similar to [Figure 108](#)[Figure 102](#) for Hot Aisle cooling, [Figure 113](#)[Figure 107](#) below shows the ASIC supportable power curves with an overlay of three Cold Aisle server airflow capability ranges. Designers must ensure that their thermal solutions and resulting card airflow requirements fall within the range of supportable Cold Aisle system airflow velocity. Cards that are under-designed (e.g. require airflow greater than the system capability) will have thermal issues when deployed into the server system. Card designers are advised to work closely with system vendors to ensure they target the appropriate airflow and temperature boundary conditions for both Hot and Cold Aisle cooling.

Figure 113107: Server System Airflow Capability – SFF Cold Aisle Cooling

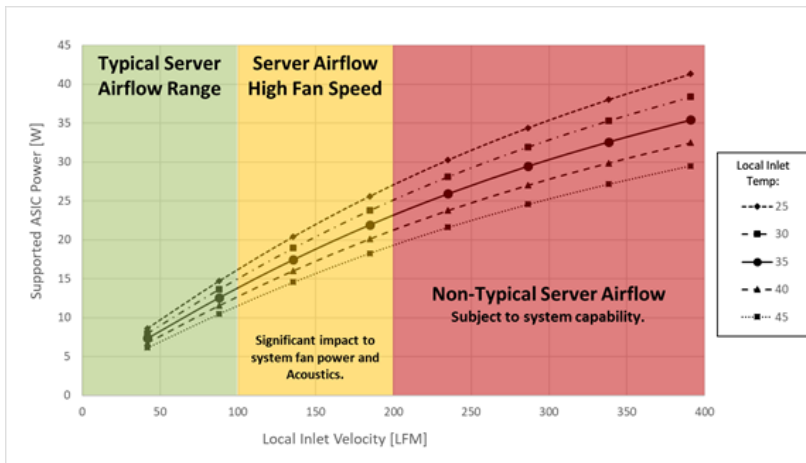

A comparison of Hot Aisle (55°C) and Cold Aisle (35°C) SFF ASIC cooling capability curves is shown below in [Figure 114](#)~~Figure 108~~. The comparison shows the Hot Aisle ASIC cooling capability at 12_W at 150_LFM while the cold Aisle cooling capability shows support for 19_W at 150_LFM. In general, based on the reference geometry, the Cold Aisle cooling configuration allows for higher supported ASIC power at lower velocities due primarily to the lower inlet temperatures local to the OCP NIC 3.0 card when in the Cold Aisle cooling configuration.

Figure [114108](#): ASIC Supportable Power Comparison – SFF Card

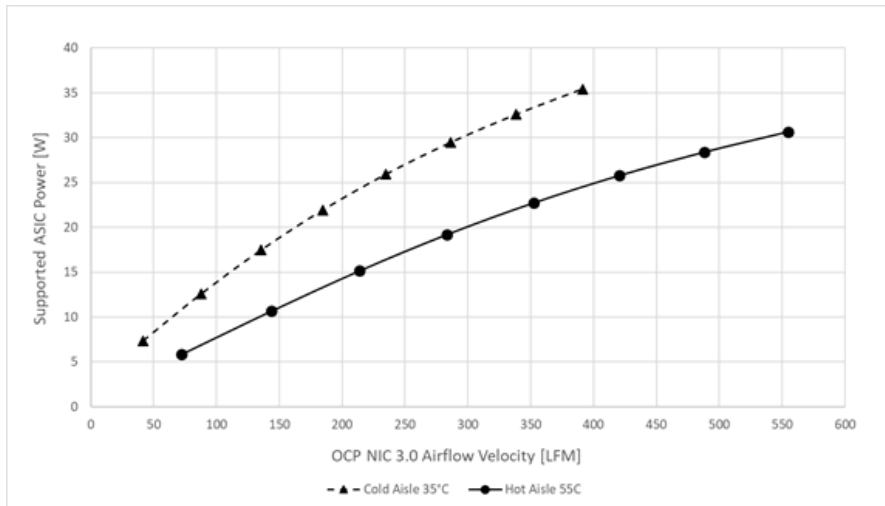

6.2.4 LFF Card ASIC Cooling – Cold Aisle

The ASIC cooling analysis for the LFF card in Cold Aisle configuration was conducted utilizing the same geometry and boundary conditions described in [Figure 110](#) and [Table 60](#) with airflow moving from I/O connector to ASIC (opposite to the Hot Aisle analysis). [Figure 115](#) below shows the results of this analysis for the Cold Aisle cooling configuration. Each curve in [Figure 115](#) represents a different system inlet air temperature from 25°C to 45°C.

Figure 115: ASIC Supportable Power for Cold Aisle Cooling – LFF Card

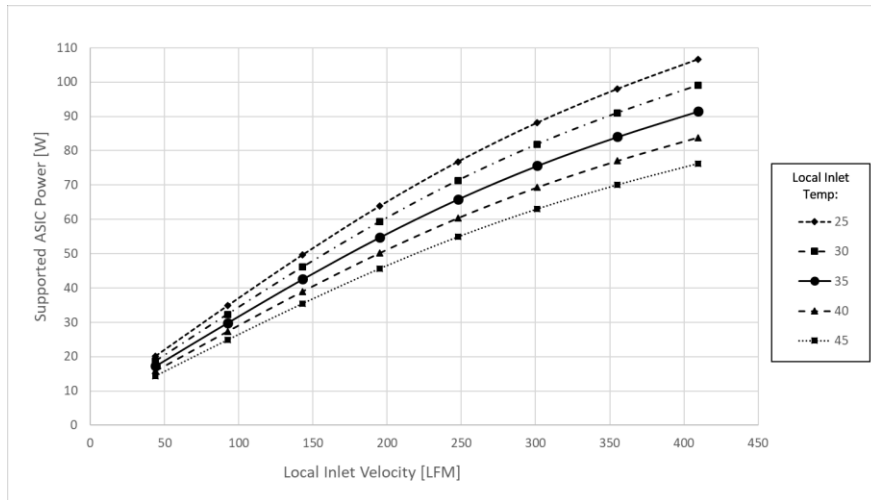

Similar to [Figure 113](#) for LFF Hot Aisle cooling, [Figure 116](#) below shows the LFF ASIC supportable power curves with an overlay of three Cold Aisle server airflow capability ranges. Designers must ensure that their thermal solutions and resulting card airflow requirements fall within the range of supportable Cold Aisle system airflow velocity. Cards that are under-designed (e.g. require airflow greater than the system capability) will have thermal issues when deployed into the server system. Card designers are advised to work closely with system vendors to ensure they target the appropriate airflow and temperature boundary conditions for both Hot and Cold Aisle cooling.

Figure 116410: Server System Airflow Capability – LFF Cold Aisle Cooling

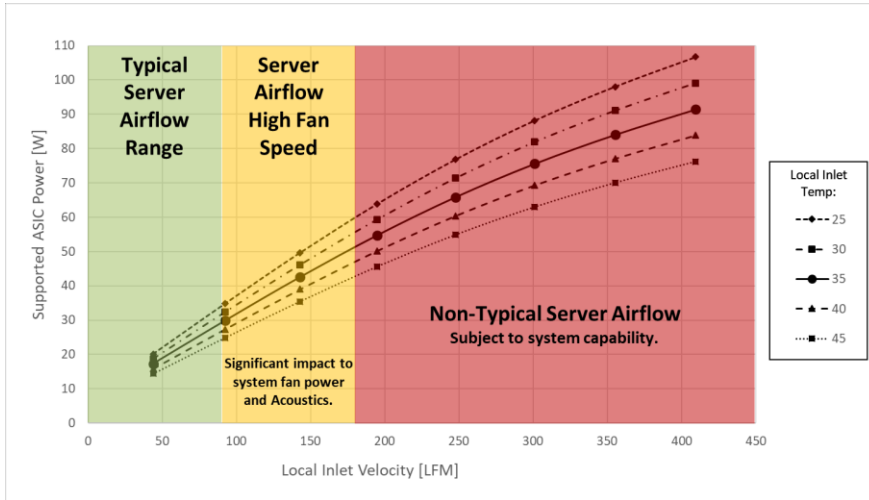

A comparison of Hot Aisle (55°C) and Cold Aisle (35°C) LFF ASIC cooling capability curves is shown below in [Figure 117141](#). The comparison shows the Hot Aisle ASIC cooling capability at 19_W at 150_LFM while the cold Aisle cooling capability shows support for 42_W at 150_LFM. In general, based on the reference geometry, the Cold Aisle cooling configuration allows for higher supported ASIC power at lower velocities due primarily to the lower inlet temperatures local to the OCP NIC 3.0 card when in the Cold Aisle cooling configuration.

Figure 117141: ASIC Supportable Power Comparison – LFF Card

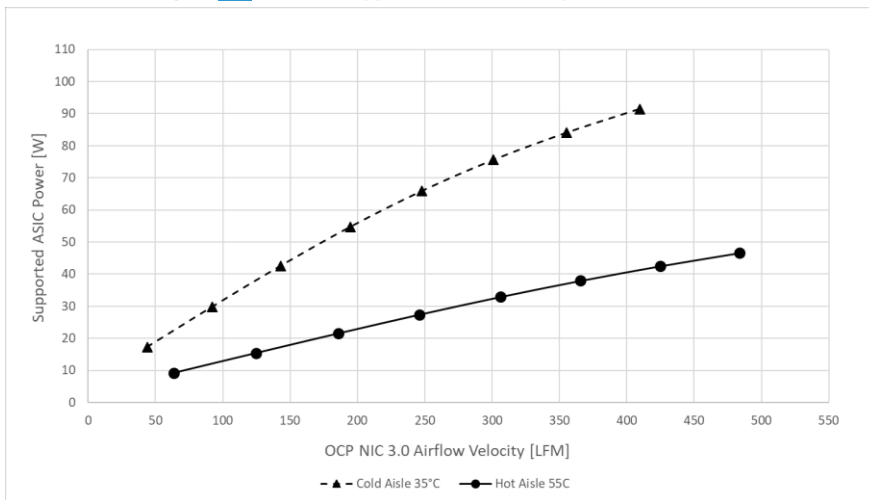

6.3 Thermal Simulation (CFD) Modeling

CFD models of the SFF and LFF cards developed for the analysis detailed in Section 6.2 are available for download on the OCP NIC 3.0 Wiki: <http://www.opencompute.org/wiki/Server/Mezz>

The thermal models available on the wiki site are in Icepak format. CAD step file exports from those models are also available to aid in re-creation of the models in other CFD software tools. Note that the geometry utilized in the CFD models is based on the OCP NIC 3.0 thermal test fixture detailed in Section 6.4.

Thermal simulation of OCP NIC 3.0 cards using the provided CFD models is recommended. Ideally, vendors developing OCP NIC 3.0 cards would perform CFD analysis to validate card thermal solutions using the provided CFD models prior to building card prototypes. One prototype is available, vendors would then perform thermal testing on the functional cards using the thermal test fixtures detailed in Section 6.4.

6.4 Thermal Test Fixture

Thermal test fixtures have been developed for SFF and LFF OCP NIC 3.0 cards. The test fixtures are intended to provide a common thermal test platform for card vendors, server vendors, and other industry groups planning to develop or utilize the OCP NIC 3.0 card form factors. Details of the thermal test fixtures are as follows:

- Sheet metal side walls, base, faceplate, and top cover
- Thumbscrew top cover access
- PCB sandwiched between base and side walls
- Intended for attachment to wind tunnel or flow bench such as those available at: <http://www.fantester.com/>
- Allows for thermal testing of functional OCP NIC 3.0 cards in a metered airflow environment
- Input power from external power supplies allows for OCP NIC 3.0 card power measurement
- Power connections for 3.3_V, GND, GND, 12_V (SFF)
- Power connections for 3.3_V, GND, GND, GND, 12_V, 12_V (LFF)
- RJ45 connector for NC-SI pass-through
- USB Type-X connector for microprocessor connectivity
- Functions as a remote PCIe extension with intent to position host server under the fixture for connection to system PCIe slot
- Single x16 connection to server host on bottom side of the fixture PCB (SFF)
- Dual x16 connection to server host on bottom side of the fixture PCB (LFF)
- Predefined locations for fixture airflow/temperature sensors on fixture PCB silkscreen. Quantity 3x per board.
- Quantity 4x for LFF – see [Figure 123](#)~~Figure 117~~

- Candlestick style sensors [are](#) available at:
<https://www.gats.com/Products/Instruments/Temperature-and-Velocity-Measurement/Sensors/Candlestick-Sensor>
- Candlestick sensors must be procured separately, not integrated with fixture PCB
- Blockage above OCP3 card to mimic system geometry and prevent airflow bypass
- Low profile PCIe card for SFF fixture
- Block sheet metal obstruction built into the top cover for the LFF fixture

CAD Files for the current revision of the test fixture are available for download on the OCP NIC 3.0 Wiki:
<http://www.opencompute.org/wiki/Server/Mezz>.

6.4.1 Test Fixture for SFF Card

Images of the SFF thermal test fixture are shown in [Figure 118](#)[Figure 112](#) and [Figure 119](#)[Figure 113](#). The SFF fixture PCB is shown in [Figure 120](#)[Figure 114](#). Note the three candlestick sensor locations directly next to the OCP NIC 3.0 connectors.

Figure ~~118~~[112](#): SFF Thermal Test Fixture Preliminary Design

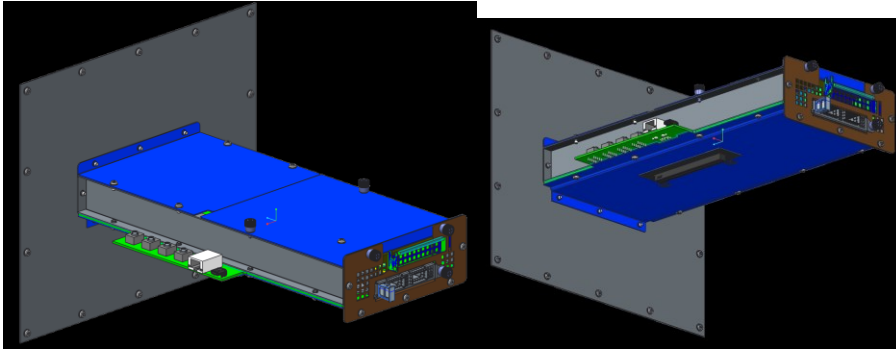

Figure [119413](#): SFF Thermal Test Fixture Preliminary Design – Cover Removed

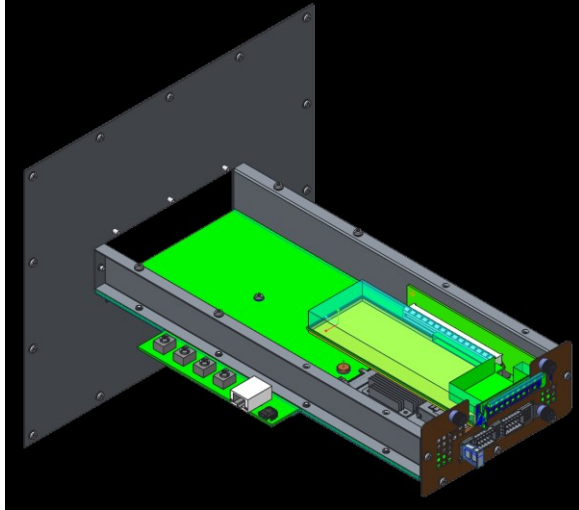
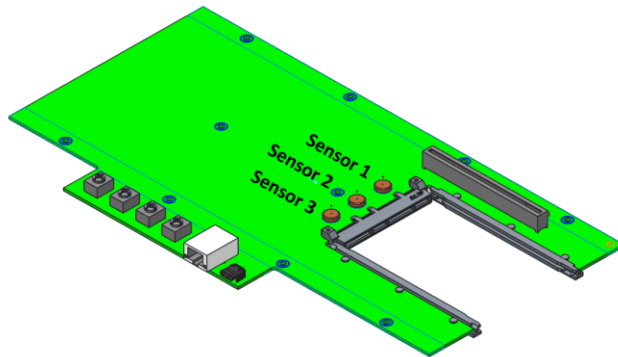

Figure [120444](#): SFF Card Thermal Test Fixture PCB



6.4.2 Test Fixture for LFF Card

Images of the LFF thermal test fixture are shown in [Figure 121](#)[Figure 115](#) and [Figure 122](#)[Figure 116](#). The LFF fixture PCB is shown in [Figure 123](#)[Figure 117](#). Note the three candlestick sensor locations directly next to the OCP NIC 3.0 connectors.

Figure [121](#)[115](#): LFF Card Thermal Test Fixture Design

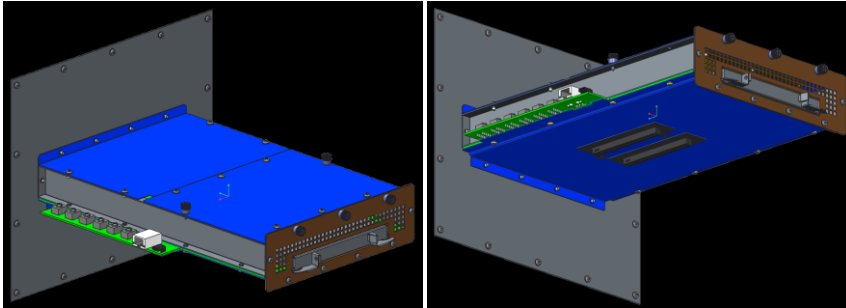

Figure [122416](#): LFF Card Thermal Test Fixture Design – Cover Removed

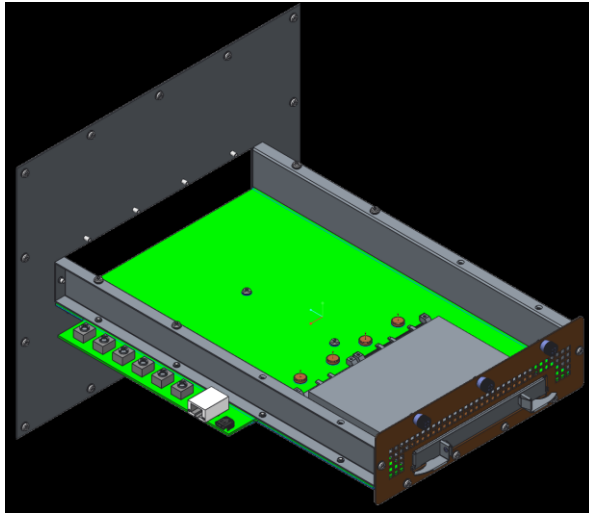
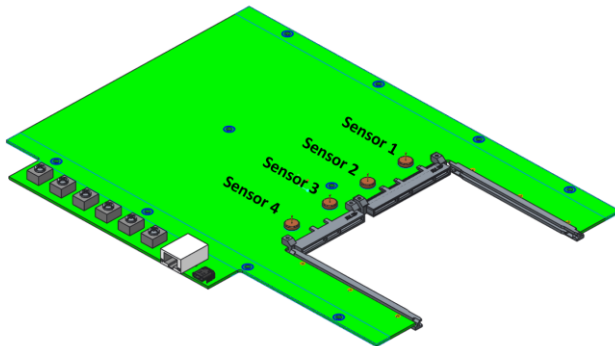

Figure [123417](#): LFF Card Thermal Test Fixture PCB



6.4.3 Test Fixture Airflow Direction

When utilizing the OCP NIC 3.0 thermal test fixture, the wind tunnel or flow bench must be configured to push airflow for hot aisle cooling or to pull airflow for cold aisle cooling as shown in [Figure 124](#)~~Figure 118~~.

Figure ~~124~~~~118~~: Thermal Test Fixture Airflow Direction

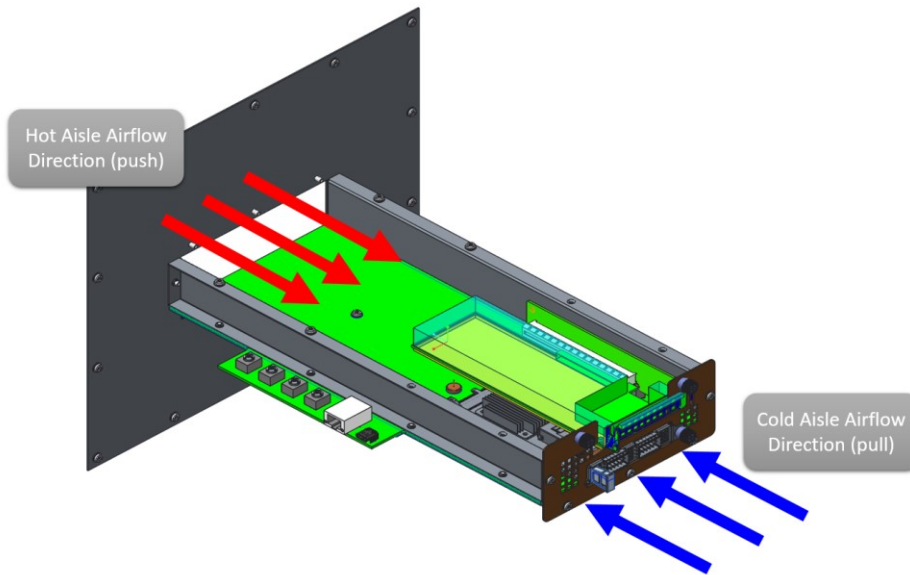

6.4.4 Thermal Test Fixture Candlestick Sensors

As noted in previously, candlestick sensor locations are included on the fixture PCB silkscreen. These candlestick sensors provide point measurements for both airflow velocity (LFM) and air temperature. The airflow at the inlet to the OCP NIC 3.0 will differ from the fixture mean velocity due to the obstructions above the OCP NIC 3.0 cards within the fixture. Thus, the fixture flow rate and cross-sectional area should not be used to determine the local velocity at the OCP NIC 3.0 card. Instead, the candlestick velocity/temperature sensors should be utilized to directly measure the local inlet velocity to the cards for hot aisle cooling.

[Figure 125](#)~~Figure 119~~ and [Figure 126](#)~~Figure 120~~ below show the air velocity at each sensor location vs. the total fixture flow rate in CFM. The curves shown in these figures are based on the data collected from the CFD models discussed in Section 6.3. Note the error between the ~~velocity~~~~velocities~~ obtained from the sensor locations vs. the velocity based on the duct cross-sectional area.

Figure [125119](#): SFF Fixture, Hot Aisle Flow - Candlestick Air Velocity vs. Volume Flow

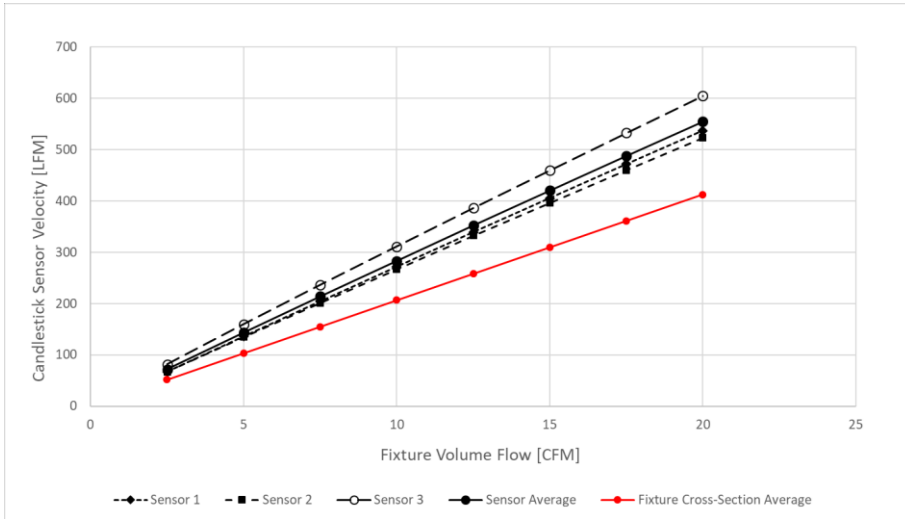
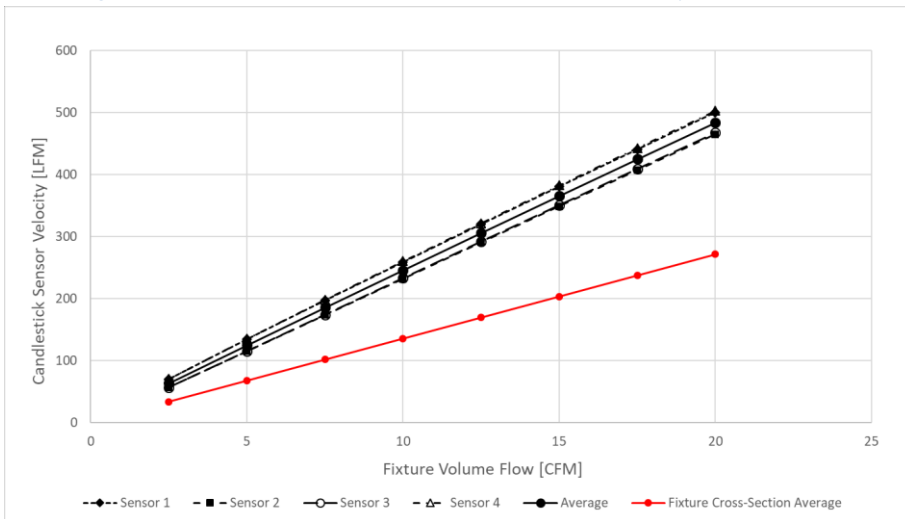

Figure [126120](#): LFF Fixture, Hot Aisle Flow - Candlestick Air Velocity vs. Volume Flow



6.5 Card Sensor Requirements

See Sections 4.4 to 4.6 for information relating to temperature sensor and reporting requirements.

6.6 Card Cooling Tiers

Section 4.10.2 defines a number of registers that may be read by the associated baseboard system. Two of these registers provide the Hot Aisle and Cold Aisle Card Cooling Tiers that may be used for fan speed control. The Card Cooling Tiers relate the card local inlet temperature to the required local inlet velocity which allows the system to set fan speeds according to the cooling requirements of the card.

The Card Cooling Tier registers are particularly useful for systems that do not implement temperature sensor monitoring. The registers may also be used as a backup for cards that do implement temperature sensor monitoring.

6.6.1 Hot Aisle Cooling Tiers

Card Cooling Tiers for Hot Aisle Cooling are defined in [Table 61Table-67](#). The values in the table are listed with units shown in LFM. Future releases of this specification will provide more detail to the Card Cooling Tier curve definition.

Table [6167](#): Hot Aisle Card Cooling Tier Definitions (LFM)

OCP NIC 3.0 Local Inlet Temperature [°C]	Target Operating Region				Server Airflow High Fan Speed		Non-Typical Server Airflow - Subject to System Capability					
	Tier 1	Tier 2	Tier 3	Tier 4	Tier 5	Tier 6	Tier 7	Tier 8	Tier 9	Tier 10	Tier 11	Tier 12
5												
10												
15												
20												
25												
30												
35												
40												
45												
50												
55	50	100	150	200	250	300	350	400	450	500	750	1000
60												
65												

Work in Progress

6.6.2 Cold Aisle Cooling Tiers

Card Cooling Tiers for Cold Aisle Cooling are defined in [Table 62Table-68](#). The values in the table are listed with units shown in LFM. Future releases of this specification will provide more detail to the Card Cooling Tier curve definition.

Table ~~6268~~: Cold Aisle Card Cooling Tier Definitions (LFM)

OCP NIC 3.0 Local Inlet Temperature [°C]	Target Operating Region				Server Airflow High Fan Speed		Non-Typical Server Airflow - Subject to System Capability					
	Tier 1	Tier 2	Tier 3	Tier 4	Tier 5	Tier 6	Tier 7	Tier 8	Tier 9	Tier 10	Tier 11	Tier 12
5												
10												
15												
20												
25												
30												
35	50	100	150	200	250	300	350	400	450	500	750	1000
40												
45												
50												
55												
60												
65												

Work in Progress

6.7 Non-Operational Shock & Vibration Testing

OCP NIC 3.0 components are deployed in various environments. As such, all OCP NIC 3.0 cards shall be subjected to shock and vibration testing to ensure products do not sustain damage during normal operational or transportation conditions. While end customer deployments may require an additional final system level test, this section sets the minimum shock and vibration requirements for an OCP NIC 3.0 card that must also be considered.

Shock and vibration testing shall be done in accordance with the procedures listed below. The tests shall be conducted using a vertical shock table. The OCP NIC 3.0 card shall be ~~fixtured-secured~~ in the standard test fixture as described in Section 6.7.1.

6.7.1 Shock & Vibe Test Fixture

TBD. Working group to provide description and mechanical details and figures.

6.7.2 Test Procedure

The following procedures shall be followed for the shock and vibration testing:

- A minimum sample size of three OCP NIC 3.0 cards shall be subjected to shock and vibration.
- All samples shall be verified for functionality prior to test.
- The OCP NIC 3.0 card shall be fixtured to simulate how the card will be mounted within a system. For example, the OCP NIC 3.0 card may be fixtured in the horizontal plane with the primary component side facing up for certain chassis configurations.
- The fixture shall be tested on all 6 sides. Each side shall be clearly labeled as 1-6 for test identification purposes. Testing shall be performed in the vertical axis only. The fixture shall be rotated until all six sides have been tested as the product may be dropped from any orientation during handling. Testing shall not be conducted on a three axis slip table.
- Non-operational vibration testing is performed at 1.88_{G_{RMS}} for a duration of 15 minutes per side for all six surfaces per ~~Table 63~~Table-69.

Commented [JH17]: Have requested S&V requirements from community. Will provide once I get the majority of responses.

9/22 update – Survey’s sent, very light response...

Table 6369: Random Vibration Testing 1.88_G_{RMS} Profile

Frequency (Hz)	G ² /Hz
10	0.13
20	0.13
70	0.004
130	0.004
165	0.0018
500	0.0018

- Non-operational half-sine shock test at 71_G ±5% with a 2_ms duration. All six sides shall be tested.
- Non-operational square wave shock test at 32_G ±5% at a rate of 270 inches/sec. All six sides shall be tested.
- All cards shall be checked for proper operation after the shock and vibration tests have been conducted. All three samples must be in full operating order to consider the product as a pass.

6.8 Dye and Pull Test Method

All Dye and Pull test methods shall be implemented per the IPC-TM-650 method 2.4.53 (Dye and Pull Test Method – formerly known as Dye and Pry). The Dye and Pull test uses a colored dye penetrant to visually indicate cracked solder joints on BGA devices. The test shall only be conducted after the Shock and Vibration testing has been conducted on the test samples. The Dye and Pull Test Method is a destructive test.

- A minimum sample size of three OCP NIC 3.0 cards shall be subjected to the Dye and Pull Test Method.
- All samples shall be first subjected to the Shock and Vibration testing outlined in Section 6.7.
- All samples shall be subjected to the preparation and test procedures of IPC-TM-650 method 2.4.53.
- Following the pull-test operation, the board sample shall be examined for dye indication at the target BGA area. Separation locations are categorized in to the following five areas:
 - Type 1 – Separation between the BGA copper pad and the BGA substrate.
 - Type 2 – Separation between the BGA copper pad and the BGA solder sphere.
 - Type 3 – Separation between the BGA solder sphere and the copper pad on the PCB.
 - Type 4 – Separation between the copper pad on the PCB and the PCB laminate.
 - Type 5 – Separation of the BGA solder sphere.

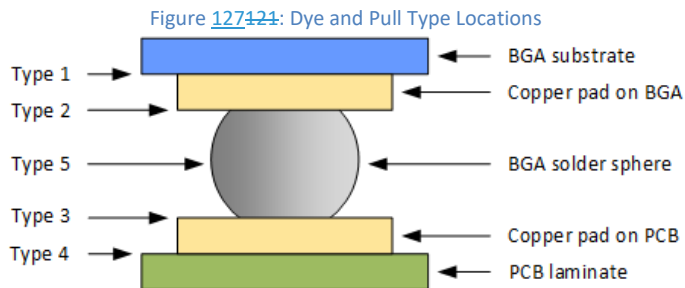

- Samples shall be subjected to the following failure criteria:
 - Dye coverage of >50% (“D” and “E” in [Figure 128Figure-122](#)) of any Type 2 or Type 3 BGA cracks are present in the test sample.
 - One or more Type 1 or Type 4 BGA cracks are present in the test sample.

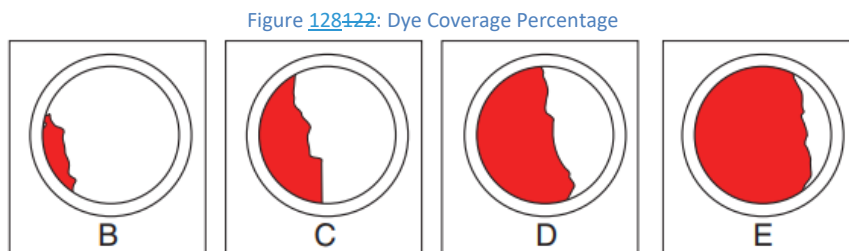

The following exceptions are allowed:

- For “via-in-pad” designs, dye is allowed on the laminate surface (under the pad), as long as the dye has not entered the inner-via laminate area, or is found on the separated via-barrel wall.
- Allowances for dye indications exceeding the 50% limit on mechanical (non-electrical) BGA corner locations or multiple use locations (grounds, powers) may be determined by the appropriate Engineering Team.

6.9 Gold Finger Plating Requirements

This section defines the minimum plating/quality requirements for the OCP NIC 3.0 gold fingers.

6.9.1 Host Side Gold Finger Plating Requirements

Per Section 6.4 (Environmental Requirements) of the PCIe CEM specification, the minimum host side gold finger plating is 30 microinches of gold over 50 microinches of nickel. OCP NIC 3.0 card vendors shall individually evaluate the minimum plating required.

The recommendation for OCP NIC 3.0 is to 30 microinches of gold over 150 microinches of nickel.

6.9.2 Line Side Gold Finger Durability Requirements

The line side connectors must be designed to support a minimum of 250 error free insertion cycles. In order to accomplish this, it is required that the minimum contact plating be as follows:

- SFP and QSFP connectors: 30 microinches of gold over 50 microinches of nickel
- RJ45 connectors have a minimum of 50 microinches of gold over 50 microinches of nickel

Commented [TN18]: Line side plating / durability requirements are being discussed in the OCP NIC 3.0 Workgroup.

7 Regulatory

7.1 Required Compliance

An OCP NIC 3.0 card shall meet the following Environmental, EMC and safety requirements.

Note: Emissions and immunity tests in Section 7.1.4 are to be completed at the system level. The OCP NIC 3.0 vendors should work with the system vendors to achieve the applicable requirements listed in this section.

7.1.1 Required Environmental Compliance

- China RoHS Directive
- **EU RoHS 2 Directive (2011/65/EU)** aims to reduce the environmental impact of electronic and electrical equipment (EEE) by restricting the use of certain hazardous materials. The substances banned under RoHS are lead, mercury, cadmium, hexavalent chromium, polybrominated biphenyls, polybrominated diphenyl ether, and four phthalates.
- **EU REACH Regulation (EC) No 1907/2006** addresses the production and use of chemical substances and their potential impact on human health and the environment.
- **EU Waste Electrical and Electronic Equipment (“WEEE”) Directive (2012/19/EU)** - mandates the treatment, recovery and recycling of EEE.
- **The Persistent Organic Pollutants Regulation (EC) No. 850/2004** bans production, placing on the market and use of certain persistent organic pollutants.
- **The California Safe Drinking Water and Toxic Enforcement Act of 1986 (“Prop 65”)** sets forth a list of regulated chemicals that require warnings in the State of California.
- **The Packaging and Packaging Waste Directive 94/62/EC** limits certain hazardous substances in the packaging materials
- **Batteries Directive 2006/66/EC** regulates the manufacture and disposal of all batteries and accumulators, including those included in appliances.

7.1.2 Required EMC Compliance

- Radiated and Conducted Emissions requirements are based on deployed geographical locations. Refer to [Table 64Table 70](#) for details.

Table ~~6470~~: FCC Class A Radiated and Conducted Emissions Requirements Based on Geographical Location

Targeted Geography	Applicable Specifications
USA	FCC, 47 CFR Part 15, Class A digital device (USA)
Canada	ICES-003, class A (CAN)
EU	EN 55032: 2015+AC:2016 Class A Radiated and Conducted Emissions requirements for European Union EN 55024: 2010+A1:2015 Immunity requirements for European Union (EU)
Australia/New Zealand	AS/NZS CISPR 32:2015 Class A CISPR 32:2015 for Radiated and Conducted Emissions requirements

Japan	VCCI 32-1 Class A Radiated and Conducted Emissions requirements
Korea	KN32 – Radiated and Conducted Emissions KN35- Immunity
Taiwan	BSMI CNS13438: 2006 (complete) Class A Radiated and Conducted Emissions requirements

- **CE** – Equipment must pass the CE specification
- All technical requirements covered under **EMC Directive (2014/30/EU)**

7.1.3 Required Product Safety Compliance

- Safety - requirements are listed in [Table 65](#)~~Table 71~~.

Table ~~65~~~~71~~: Safety Requirements

Targeted Category	Applicable Specifications
Safety	UL 60950-1/CSA C22.2 No. 60950-1-07, 2nd Edition + Amendment 1 + Amendment 2, dated 2011/12/19. The Bi-National Standard for Safety of Information Technology Equipment, EN60950-1: 2006+A11:2009+A1:2010+A12:2010+A2:2013 IEC 60950-1 (Ed 2) + A1 + A2. 62368-1 may also be co-reported depending on region

7.1.4 Required Immunity (ESD) Compliance

The OCP NIC 3.0 card shall meet or exceed the following ESD immunity requirements listed in [Table 66](#)~~Table 72~~.

Table ~~66~~~~72~~: Immunity (ESD) Requirements

Targeted Category	Applicable Specifications
Immunity (ESD)	EN 55024 2010, and IEC 61000-4-2 2008 for ESD. Required ± 4 kV contact charge and ± 8 kV air discharge
NEBS Level ## 3 (optional)	Optionally test devices to NEBS level Level 3 – Required ± 8 kV contact charge and ± 16 15 kV air discharge with interruptions not greater than 2 seconds. The device shall self-recover without operator intervention. Note: NEBS compliance is part of the system level testing. The OCP NIC 3.0 specification is providing a baseline minimum recommendation for ESD immunity.

7.2 Recommended Compliance

All ~~the~~ OCP NIC 3.0 cards ~~are required to meet the requirements specified in Section 7.1. Card vendors should also consider meeting the requirements below~~ ~~is recommended to meet below compliance requirements.~~

7.2.1 Recommended Environmental Compliance

- **Halogen Free:** IEC 61249-2-21 Definition of halogen free: 900ppm for Bromine or Chlorine, or 1500ppm combined total halogens.
- **Arsenic:** 1000 ppm (or 0.1% by weight)
- **Emerging: US Conflict Minerals law: section 1502 of the Dodd-Frank Act** requires companies using tin, tantalum, tungsten, and gold (“3TG”) in their products to verify and disclose the mineral source. While this does not apply to products that are used to provide services, such as Infrastructure hardware products, the OCP NIC Subgroup is considering voluntarily reporting of this information.

7.2.2 Recommended EMC Compliance

- [FCC, 47 CFR Part 15, Subpart B Class A digital device \(USA\) with 10dB margin_ to FCC sub part 15 b class A emission requirements as specified in](#) Refer to the baseline requirements shown in Section 7.1.2 [for details.](#)

8 Revision History

Author	Description	Revision	Date
OCP NIC 3.0 Subgroup	Initial public review.	0.70	01/25/2018
OCP NIC 3.0 Subgroup	<ul style="list-style-type: none"> - Implemented comments from 0.70 review. - LED implementation updated. - Gold finger lengths updated. All pins are full length except for PCIe TX/RX, REFCLKS and PRSNT pins. 	0.71	02/06/2018
OCP NIC 3.0 Subgroup	<ul style="list-style-type: none"> - Updates to Section 4.x per the working group session. 	0.72	02/21/2018
OCP NIC 3.0 Subgroup	<ul style="list-style-type: none"> - Change NC-SI Over-over RBT RXD/TXD pins to a pull-up instead of a pull down. - Update power sequencing diagram. REFCLK is disabled before silicon transitions to AUX Power Mode. - Merge pinout sections 3.4 and 3.5 together for structural clarity. - Add text to gate WAKE# signal on AUX_PWR_GOOD (internal) assertion; updated diagrams with WAKE# signals to reflect implementation. - Add initial signal integrity outline to document (WIP) - Add Initial draft of the Shock and Vibration, and Dye and Pull test requirements. - Rearrange Section 2 for structure; changed section name to Mechanical Card Form Factor - Move non-NIC use cases to Section 1.5. - Moved Port numbering and LED definitions to Section 3.8. - Add secondary side LED placement for 4x SFP and 2x QSFP implementations in Section 3.8. - Revised labeling section (Section 2.9). - Optimize the scan chain LED bit stream for dual port applications. - Add SLOT_ID[1]. Updated text and diagrams for mapping SLOT_ID[1:0] to Package ID[2:0] and FRU EEPROM A[2:0] fields. - Reduce ID Mode power consumption on +12V_EDGE 	0.73	05/01/2018
OCP NIC 3.0 Subgroup	<ul style="list-style-type: none"> - Text clean up. All minor / generally agreed upon items within the OCP NIC 3.0 Workgroup have been accepted. - Clarify PCIe bifurcation is on a per-slot basis. Add 1x32 and 2x16 implementation examples for a Large Form Factor card. - Removed reference to a x24 PCIe width LFF card from Table 5 – OCP NIC 3.0 Card Definitions. - Move SLOT_ID[1] to OCP_A6 for immediate power on indication of the card physical location for RBT and FRU EEPROM addressing. Updated RBT addressing and Scan Chain definition to match. - Updated diagrams and text in Section 6.x based on feedback from the OCP NIC 3.0 Thermal Workgroup. - Updated diagrams and text in Section 2.0 based on feedback received from the OCP NIC 3.0 Mechanical Workgroup. 	0.74	06/04/2018
OCP NIC 3.0 Subgroup	0v80 public release	0.80	06/04/2018
OCP NIC 3.0 Subgroup	<p>0v81 public release. Changes are as follows:</p> <ul style="list-style-type: none"> - Section 1.3 - Update Figure 1 with latest thumbscrew design. - Section 2.4.2 - Mechanical corrections to BOM items 5, 6A/B, 8 & 11. - Section 3.4.3 - Add statement to isolate SMRST# if target device voltage is not powered from +3.3V_EDGE. - Section 3.4.4 – Clarified the RBT_ARB_IN and RBT_ARB_OUT pin descriptions. 	0.81	07/06/2018

	<ul style="list-style-type: none"> - Section 3.4.4 - Clarified SLOT_ID[1:0] description and example diagrams; move SLOT_ID[1:0] isolation to NIC and use direct connection to FRU EEPROM. - Section 3.4.5 - DATA_IN bit PRSNTB[3:0] definition to optionally use pull up/down to match PRSNTB[3:0]# card edge connections. - Section 3.4.7 – Add USB 2.0 definition to the Primary Connector. - Section 3.4.8 – Add UART definition to the Secondary Connector. - Section 3.4.9 - Changed Miscellaneous pins to RFU[1:2] pins. - Section 3.8 - Clarified LED placement. - Section 3.9.x - Clarified ID-Aux and Aux-Main Power Mode transition requirements to prevent sampling health status pins until cards have fully entered into Aux and Main modes to prevent false indication. - Section 3.11 - Updated hot swap consideration text to highlight available hot swap mechanisms. Actual hot swap design is outside the scope of this specification. - Section 4 - Update MCTP Type management description. - Section 4.9 - Clarified the FRU EEPROM is directly connected to the card edge. No isolation is used for the FRU EEPROM. 		
OCP NIC 3.0 Subgroup	<ul style="list-style-type: none"> - Minor editorial changes. - Changed names to “SFF” and “LFF” when referencing the two board form-factors for uniformity. - Section 3.4.1 – Changed PERST[3:0]# to be asserted low until the platform is ready to bring cards out of reset. - Section 3.5.3 – Corrected typos in the PCIe Bifurcation Decoder (Table 31) for hosts that implement 4 x2 links on the first 8 lanes when using a 4 x4 OCP NIC 3.0 card. - Section 3.5.5.3 & 3.5.5.4 – Corrected the BIF[2:0] values in the diagrams. - Section 3.7 – Corrected typos in the PCIe Bifurcation result and REFCLK mapping (Table 38 and Table 41) for single host/quad host cases with PCIe on the first 8 lanes. This change was due to propagating corrections from Table 31 from Section 3.5.3. - Section 3.8.3 – Changed faceplate LED placement for 2xQSFP to primary side. - Section 4.10.2 – Added FRU field to identify the card manageability type. 	0.82	08/03/2018
OCP NIC 3.0 Subgroup	<ul style="list-style-type: none"> - Section 5.3.4 – Removed subheadings for the PCIe test methodology. Replaced with reference text to the PCIe test specifications. 	0.83	08/29/2018
OCP NIC 3.0 Subgroup	<ul style="list-style-type: none"> - Minor editorial changes. - Add appropriate trademarks per entity usage guidelines - Section 1.x – Reorganized section, added list of acronyms. - Section 1.5, 2.x – Mechanical updates from ME team. Updates to Vendor PN, pull tab/thumb screw color. - Section 3.4.1, Section 3.5.x – Updated for LFF and applications with 32 lanes of PCIe. Included TX/RX lane indices for lanes[16:31], REFCLK[4:5], PERST[4:5]# and PWRBRK1 on the Secondary Connector. - Section 3.4.9 – Changed RFU[1:2] to RFU[3:4] for the Secondary Connector. - Section 3.7 – Removed bifurcation expansion tables. Redirected readers to the pinout/bifurcation spreadsheet on the OCP Mezz Wiki site instead. Merged Section 3.6 and 3.7 together as they both discuss PCIe REFCLK mapping. Add new diagrams depicting single, dual and quad host implementations with 1, 2, and 4 links. Diagrams show association of the link to the REFCLK and PERST signals. - Section 3.12 – Add RBT ISOLATE# to the power up/down sequencing diagrams. Changed BIF[2:0]# pins to ‘low’ state when AUX_PWR_EN is 	0.84	10/19/2018

[deasserted. Add timing value "T4" from DSP0222 to power up diagram and sequencing parameters table.](#)
[- Section 7.1.4 – Corrected typo on NEBS air discharge value for ESD testing. Changed from 16 kV to 15 kV.](#)
