

Nephos Inc

Nephos NPS4806

720G ToR Switch

Rev.10



OPEN
Compute Project

Revision History

Revision	Date	Author	Description
0.1	2/16/2016	Alex Chen	Initial Release
1.0	3/15/2016	Joe Lin	1 st cut engineering and partner feedback modification for OCP submission

Revision History.....	1
Licenses	4
Scope.....	6
Overview	6
Physical Overview	7
Dimensions.....	7
Top View	7
Front View.....	8
Front Panel LED Definitions.....	9
SFP+ Interface Module support	10
QSFP+ Interface Module Support.....	11
Rear View	11
Field Replaceable Units	12
Power Supply Modules	12
PSU Pin-Out.....	13
Fan Modules.....	13
System Overview:.....	14
Main PCB Block Diagram	14
CPU Module Block Diagram	15
PCB Board Set.....	16
Main Switch PCB	17
Main PCB Dimensions	17
Main PCB major components.....	17
Main PCB Top view.....	17
Main PCB Bottom View	18
Fan PCB	18
Fan PCB Dimensions.....	18
Fan Signal Cable	19
CPU Module PCB	20
CPU PCB Top and Bottom side	20

CPU PCB Dimensions 20

CPU PCB major components 20

Software Support 21

 BIOS support 21

 ONIE 21

 Open Network Linux 21

Power/Environmental/Agency Certifications 22

 Power Consumption..... 22

 Environmental..... 22

 Safety 22

 Electromagnetic Compatibility..... 22

 ROHS 22

Licenses

All semiconductor devices that may be referred to in this specification, or required to manufacture products described in this specification, will be considered referenced only, and no intellectual property rights embodied in or covering such semiconductor devices shall be licensed as a result of this specification or such references. Notwithstanding anything to the contrary in the CLA, the licenses set forth therein do not apply to the intellectual property rights included in or related to the semi-conductor devices identifies in the specification. These references include without limitation the reference to devices listed below. For clarity, no patent claim that reads on such semiconductor devices will be considered a “Granted Claim” under the applicable Contributor License Agreement for this specification.

Description	Manufacturer	Part Number
X86 CPU	Intel	C2538 – 2.4GHz 3.0V
SDRAM 2GB SO-DIMM w/ECC (x1)	ATP	XW1618E2GSPCQ-AO DDR3-1600 2GB Unb ECC SO-DIMM 1.35V Samsung
USB to NAND Flash 2GB	ATP	AF2GSSGH-A11
SPI NOR Flash 8MB	Winbound	W25Q64FVSSIG
TPM	STMicroelectronics	ST33ZP24AR28PVSP ST
FPGA	Microsemi	A2F200M3F-FGG256
mSATA Connector	TE Connectivity	1775838-2
AC Power Supply	Compuware	CPR-4011-4M11 Front to back airflow CPR-4011-4M21 Back to front airflow
Switching Silicon	Nephos	MT3258
10/100/1000 PHY	Broadcom	BCM54616S
CPLD	Altera	5M1270ZT144C5N *1 5M1270ZF256C5N *2
Fans	Sunon	PF40561BX-Q020-S99 (Front to Back airflow) PF40561BX-Q010-S99 (Back to Front airflow)
Cage/Connector SFP+ 2x8 (x3)	All Best	R-OP-008320-7-B-N-42-F5
Cage/Connector QSFP+ 2x2 (x1)	All Best	R-TR-Q2-4CMA-OU
Cage QSFP+ 1x2 (x1)	All Best	H-OR-Q2-4CX1-F5F
Connector QSFP+ 1x1 (x2)	All Best	R-CT-Q1-9CX2
Connector RJ45 2x1 (x1)	UDE	M1-C2100CK13-1

As of Feb 28, 2016, the following persons or entities have made this Specification available under the Open Web Foundation Final Specification Agreement (OWFa 1.0), which is available at <http://www.openwebfoundation.org/legal/the-owf-1-0-agreements>

You can review the signed copies of the Open Web Foundation Agreement Version 1.0 for this Specification at <http://opencompute.org/licensing/>, which may also include additional parties to those listed above.

Your use of this Specification may be subject to other third party rights. THIS SPECIFICATION IS PROVIDED "AS IS." No support of any kind will be provided by the contributors. The contributors expressly disclaim any warranties (express, implied, or otherwise), including implied warranties of merchantability, non-infringement, fitness for a particular purpose, completeness or title, related to the Specification. The entire risk as to implementing or otherwise using the Specification is assumed by the Specification implementer and user. IN NO EVENT WILL ANY PARTY BE LIABLE TO ANY OTHER PARTY FOR LOST PROFITS OR ANY FORM OF INDIRECT, SPECIAL, INCIDENTAL, OR CONSEQUENTIAL DAMAGES OF ANY CHARACTER FROM ANY CAUSES OF ACTION OF ANY KIND WITH RESPECT TO THIS SPECIFICATION OR ITS GOVERNING AGREEMENT, WHETHER BASED ON BREACH OF CONTRACT, TORT (INCLUDING NEGLIGENCE), OR OTHERWISE, AND WHETHER OR NOT THE OTHER PARTY HAS BEEN ADVISED OF THE POSSIBILITY OF SUCH DAMAGE.

Scope

This document outlines the technical specifications for the Nephos NPS4806 Open Switch Platform submitted to the Open Compute Foundation.

Overview

This document describes the technical specifications of the NPS4806 Top of Rack switch designed by Nephos Inc. The NPS4806 is a cost optimized switch design focused on Top of Rack deployments which support 10Gb server connectivity and providing 40Gb uplinks to the distribution/Spine layer of the network. The switch supports forty eight SFP+ ports that each operate at 1Gb or 10Gb and six QSFP+ ports that operate at 40Gb each or can be broken out into four 10Gb (or 1Gb) ports each.

The NPS4806 is a PHY-Less design with the SFP+ and QSFP+ connections directly attaching to the Serdes interfaces of the Nephos MT3258 720G Aries switching silicon providing the lowest cost, latency, and power. NPS4806 supports traditional features found in Top of Rack switches such as:

- Redundant field replaceable power supply and fan units
- Support for “Front to Back” or “Back to Front” air flow direction
- Supports a modular CPU card that allows flexibility in the CPU and/or memory configurations that can be offered.
- The NPS4806 is a 1RU design that supports standard 19” rack deployments as well as standard 21” Open Rack deployments.

Physical Overview

Dimensions

	Inches	Millimeters
Length	18.622	473
Width	17.42	442.5
Height	1.73	43.95

Top View

The top view of the NPS4806 shows the PCBs and associated components in the NPS4806 system

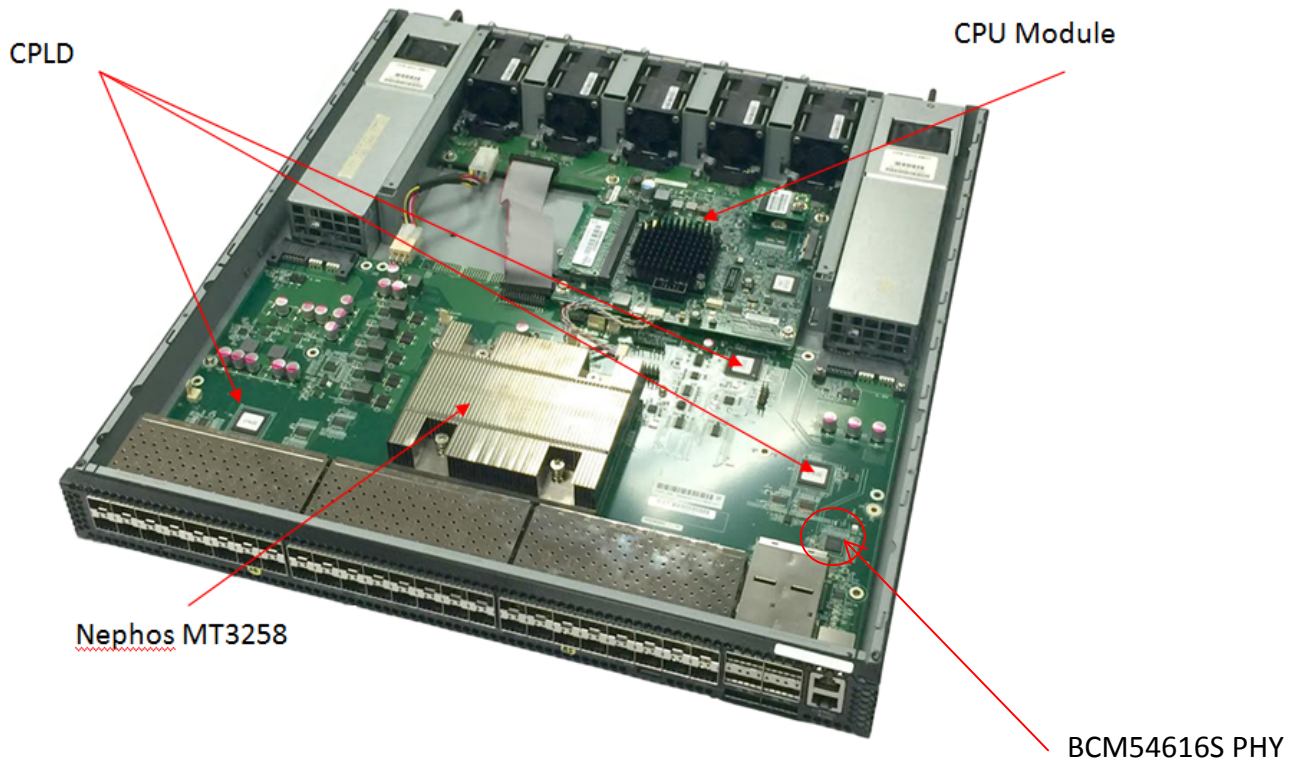

Front View

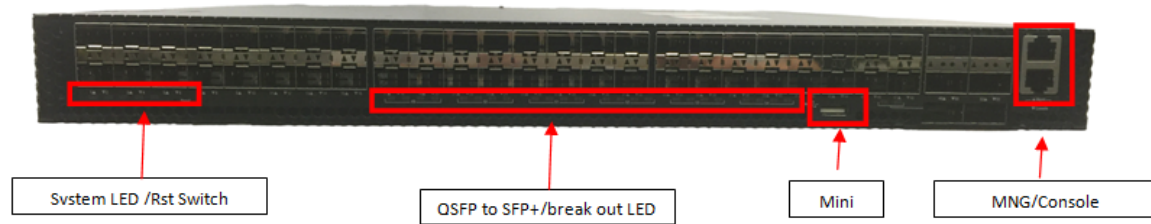

The front panel view of the NPS4806 includes the following key components:

- Forty Eight SFP+ Ports
- Six QSFP+ ports
- System LEDs
- Mini USB 2.0 type "A" port
- RJ45 RS232 management port
- RJ45 10/100/1000 Ethernet management port
- Reset switch

Front Panel LED Definitions

LED Name	Description	State	
PSU1	Led to indicate status of Power Supply 1	Green	This power is operating normally.
		Amber	PWR present but not power on or this power is fault.
		Off	Power supply not present.
PSU2	Led to indicate status of Power Supply 2	Green	This power is operating normally.
		Amber	PWR present but not power on or this power is fault.
		Off	Power supply not present.
Diag	LED to indicate system diagnostic test results	Green	System self-diagnostic test successfully completed.
		Amber	System self-diagnostic test has detected a fault. (Fan, thermal or any interface fault.)
FAN	LED to indicate the status of the system fans	Green	System FAN operating normally.
		Amber	Fan tray present buy system FAN is fault.
		OFF	System OFF
LOC	LED to indicate Location of switch in Data Center	Amber Flashing	Flashing by remote management command. Assists the technician in finding the right device for service in the rack.
		OFF	Not a particular switch that technician need to find
SFP+ LEDS	LED built into	On/Flashing Green	SFP+ port has a valid link at

	SFP+ cage (one per SFP+ port) to indicate port status		10G. Flashing indicates activity.
		On/Flashing Amber	SFP+ port has a valid link at 1G. Flashing indicates activity.
		Off	There is no link on the port.
QSFP+ Port LED (Port 49~ 54)	Each QSFP+ Port has one LED to indicate status	On/Flashing Green	SFP+ port has a valid link at 40G. Flashing indicates activity.
		Off	There is no link on the port.
QSFP+ Port LED in 10G Mode(With Breakout cable)	Each QSFP+ has four LEDs to indicate status of the individual 10G ports	On/Flashing Amber	QSFP port has a valid link at 10G via break out cable. The LED on 40G QSFP end is also present OFF. Flashing indicates activity.
		Off	There is no link on the port.
OOB LED	LED to indicate link status of 10/100/1000 management port	On	Port has a valid link
		Off	There is no link on the port
OOB LED	LED to indicate activity status of 10/100/1000 management port	Flashing	Flashing indicates activity
		Off	There is no link on the port

SFP+ Interface Module support

1Gb SFP Modules	Standard 1Gb SFP modules including but not limited to: 1000Base-T, 1000BASE-SX, 1000BASE-LX, 1000BASE-EX
10Gb SFP+ Optical Modules	Standard 10Gb SFP+ modules including but not limited to: 10GBASE-SR, 10GBASE-LR, 10GBASE-ER, AOC Cables
Direct Attach Copper (DAC)	Standard DAC cables including but not limited to Passive cable up to 5m, Active cable up to 10m

QSFP+ Interface Module Support

40Gb SFP+ Optical Modules	Standard 40Gb QSFP+ modules including but not limited to: 40GBASE-SR4, 40GBASE-LR4, 40GBASE-ER, AOC Cables
Direct Attach Copper (DAC)	Standard DAC cables including but not limited to: Passive cable up to 5m, Active cable up to 10m

Rear View

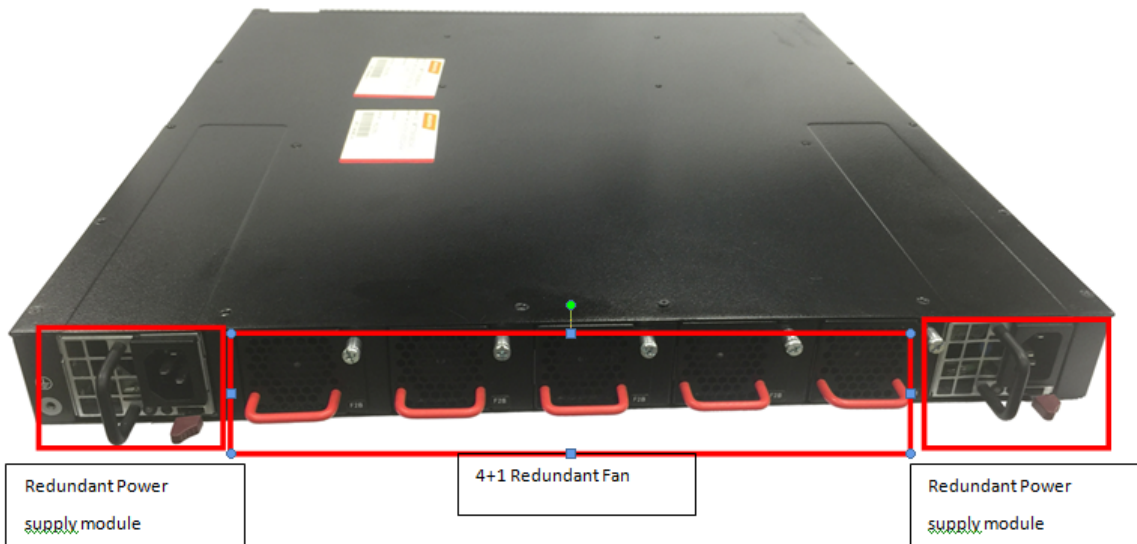

The rear view of the NPS4806 includes the following key components:

- Five (4+1) redundant hot swappable fan modules
 - LED per fan module to indicate status
 - Color coding to indicate airflow direction
- Two redundant hot swappable power supply modules
 - LED per power supply to indicate status
 - Color coding to indicate airflow direction

Field Replaceable Units

Power Supply Modules

The NPS4806 supports two redundant power supply modules as listed below

Compuware 400 Watt PSU: AC Input Range 90-264VAC / 47-63Hz		
<ul style="list-style-type: none"> • CPR-4011-4M11 Front to back airflow • CPR-4011-4M21 Back to front airflow 		
	<u>Inches</u>	<u>Millimeters</u>
Length	8.66	220
Width	1.58	40.25
Height	2.15	54.5

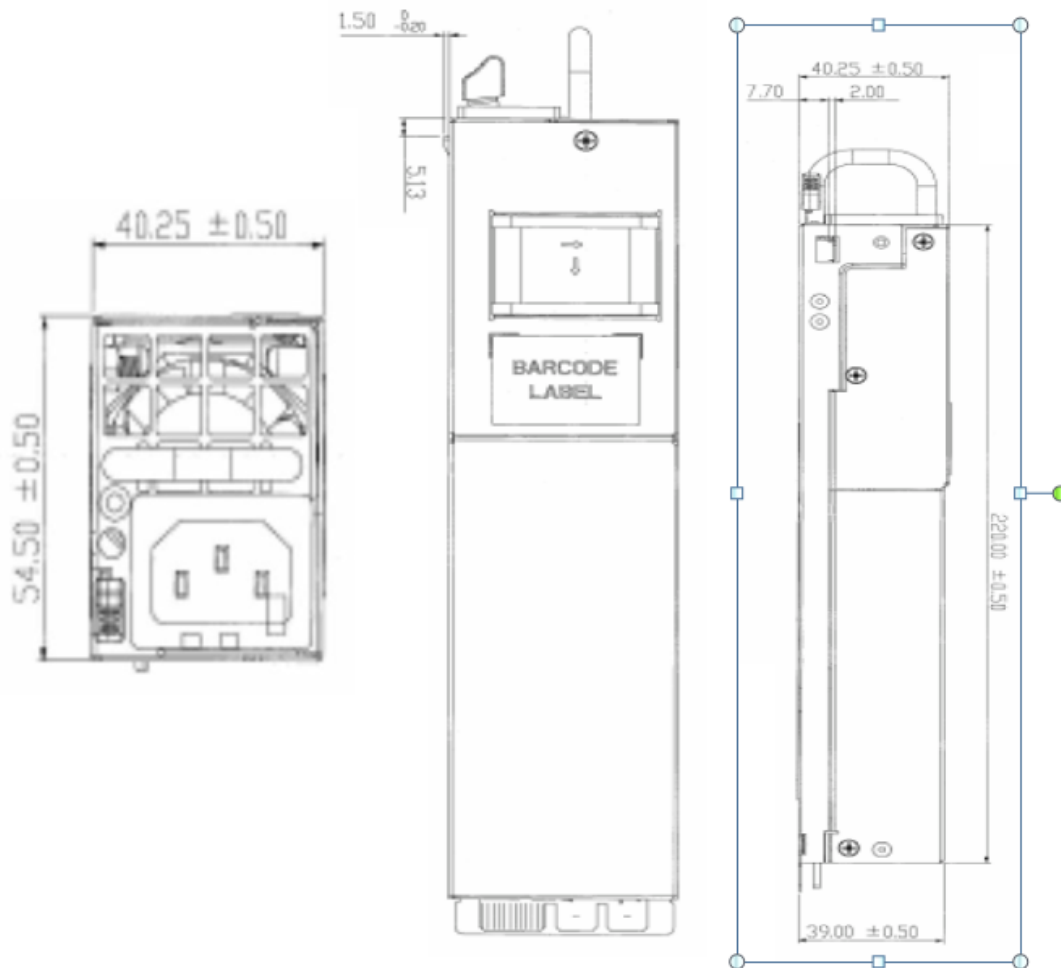

PSU Pin-Out

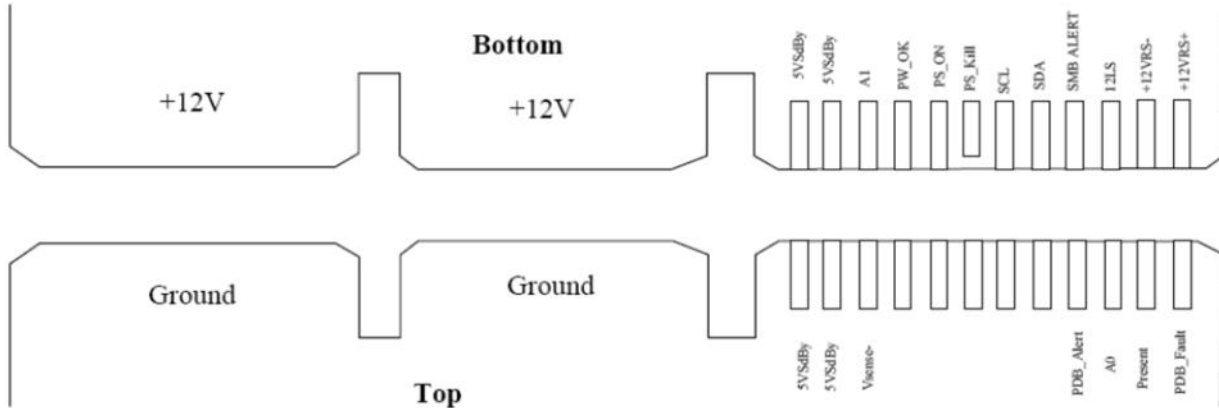

Fan Modules

The NPS4806 supports five individual fan modules. Each fan module supports two 40mmx40mmx54mm fans

Description	Manufacturer	Part Number
Fan – Front to back airflow	Sunon	PF40561BX-Q020-S99
Fan – Back to front airflow	Sunon	PF40561BX-Q010-S99

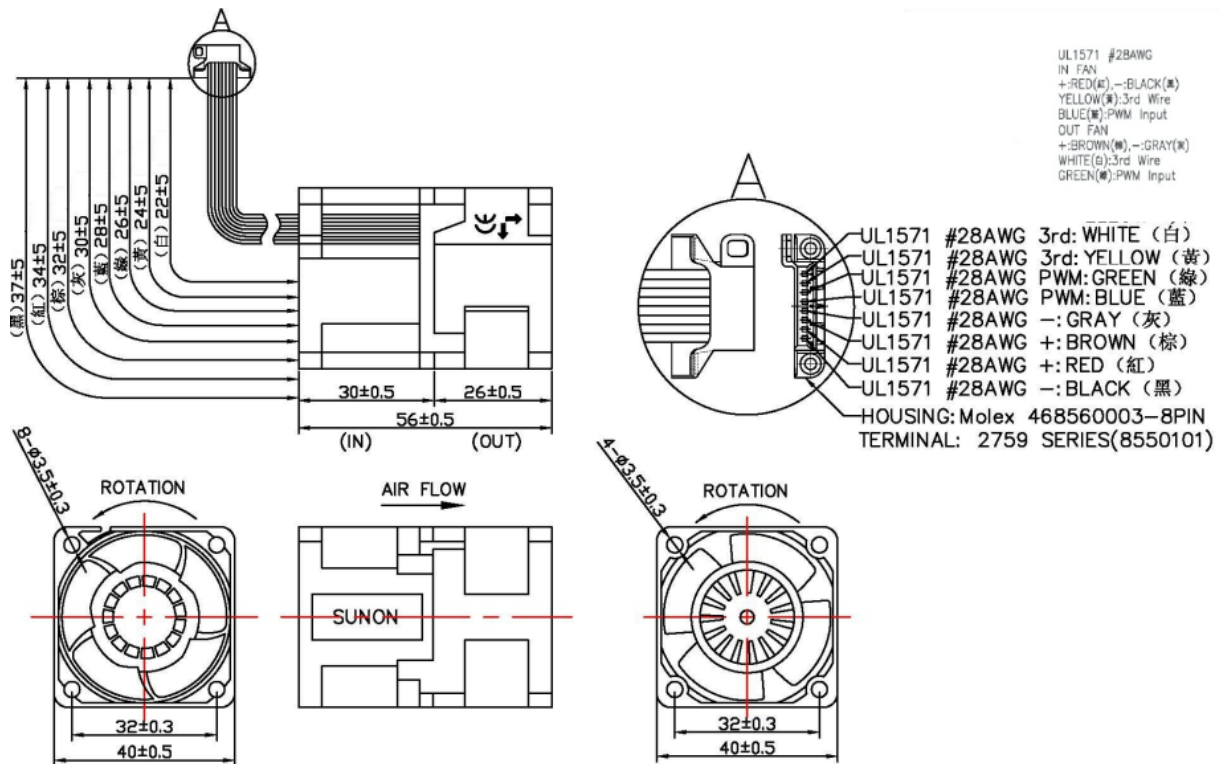

CPU Module Block Diagram

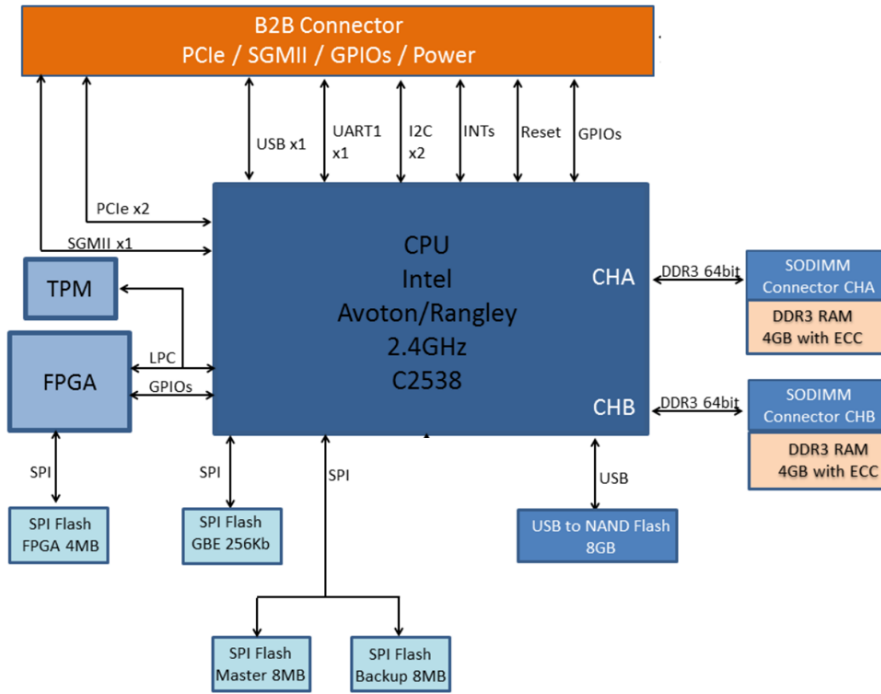

PCB Board Set

The NPS4806 is composed of 3 unique PCB assemblies as follows:

- Main switch PCB which supports the switching silicon and all front panel connections
- CPU module PCB which provides the control processor and associated components
- Fan PCB which provides connectivity for the 5 Fan modules in the system

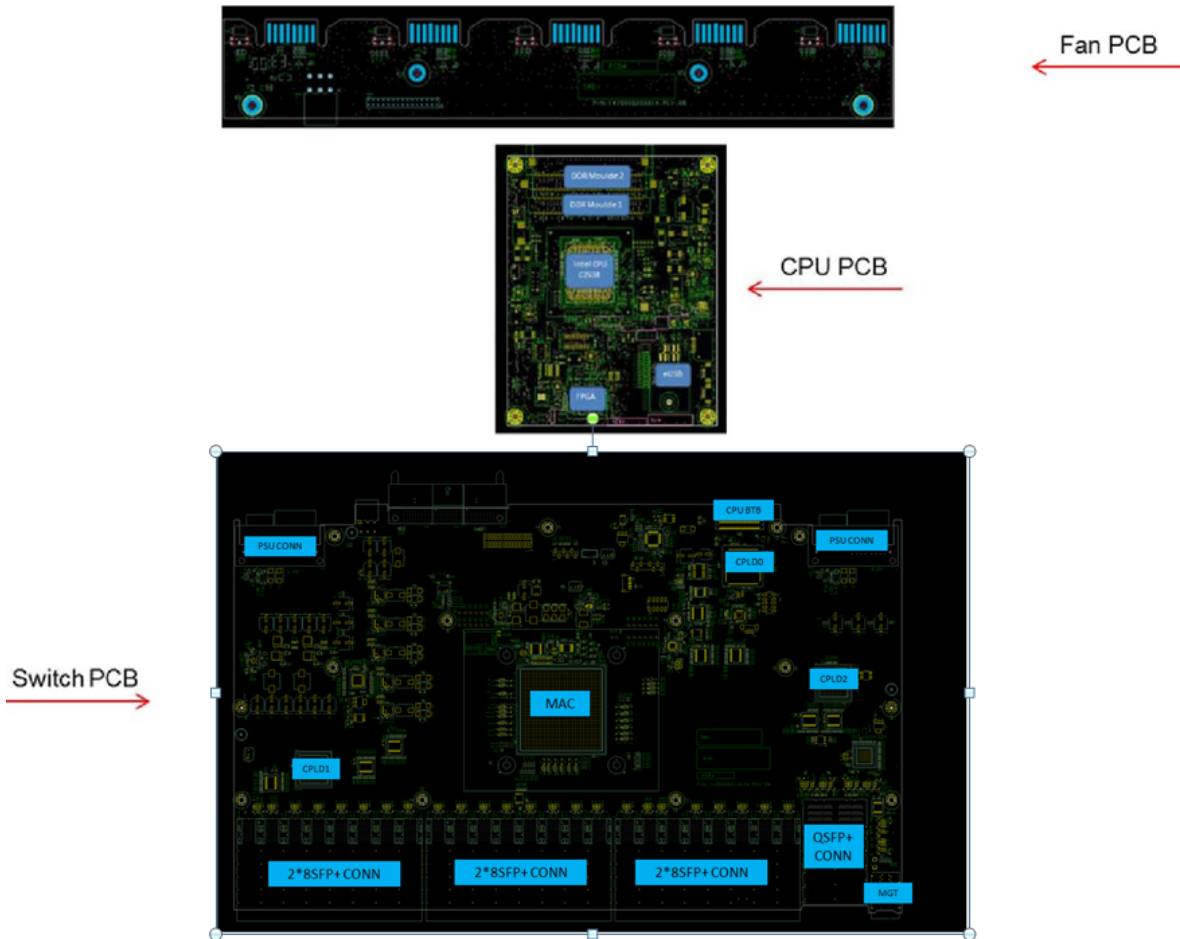

Main Switch PCB

The Main Switch PCB is a fourteen layer board supporting the switching silicon, front panel networking and management ports, LEDs, and connections to other PCBs required in building the system.

Main PCB Dimensions

	Inches	Millimeters
Length	9.95	252.70
Width	16.28	413.50

Main PCB major components

Description	Manufacturer	Part Number
Switching Silicon	Nephos	MT3258
10/100/1000 PHY	Broadcom	BCM54616S
CPLD	Altera	CPM570 (3 pieces)
Cage/Connector SFP+ 2x8 (x3)	All Best	R-OP-008320-7-B-N-42-F5
Cage/Connector QSFP+ 2x2 (x1)	All Best	R-TR-Q2-4CMA-OU
Cage QSFP+ 1x2 (x1)	All Best	H-OR-Q2-4CX1-F5F
Connector QSFP+ 1x1 (x2)	All Best	R-CT-Q1-9CX2
Connector RJ45 2x1 (x1)	UDE	M1-C2100CK13-1

Main PCB Top view

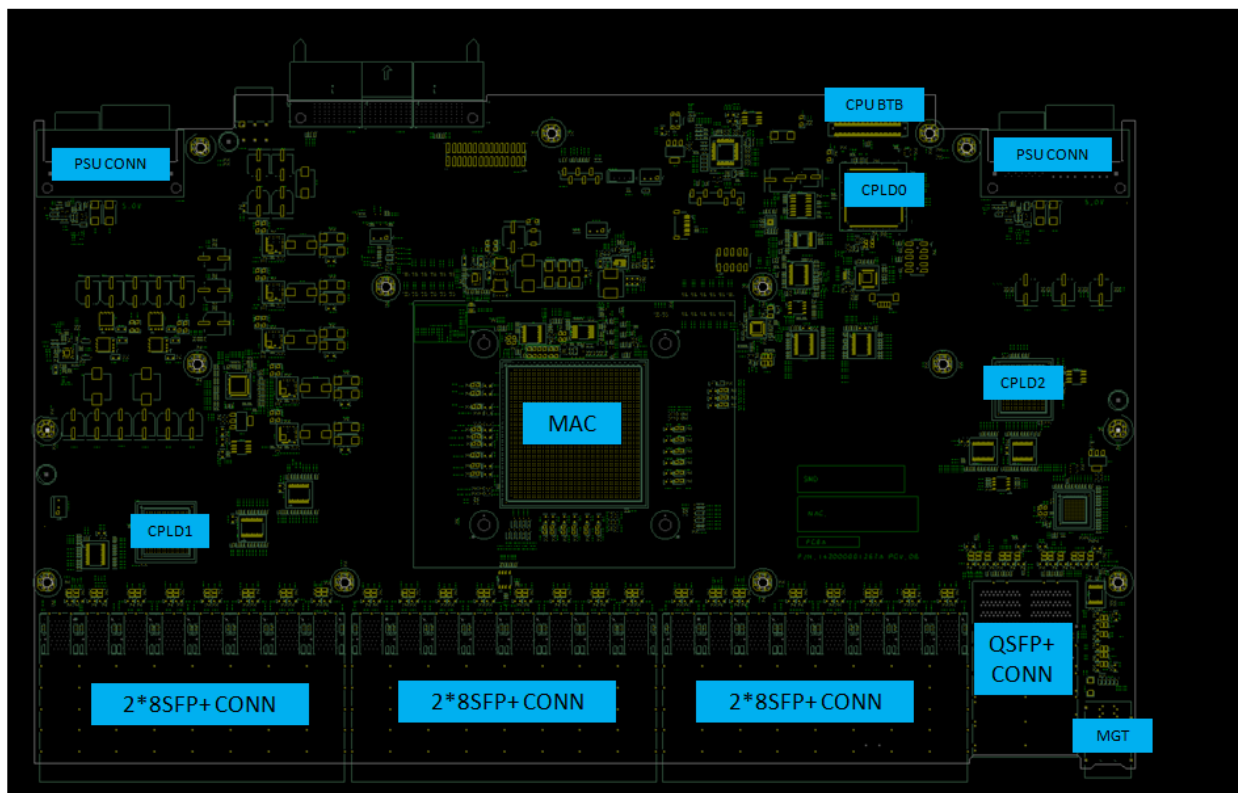

Main PCB Bottom View

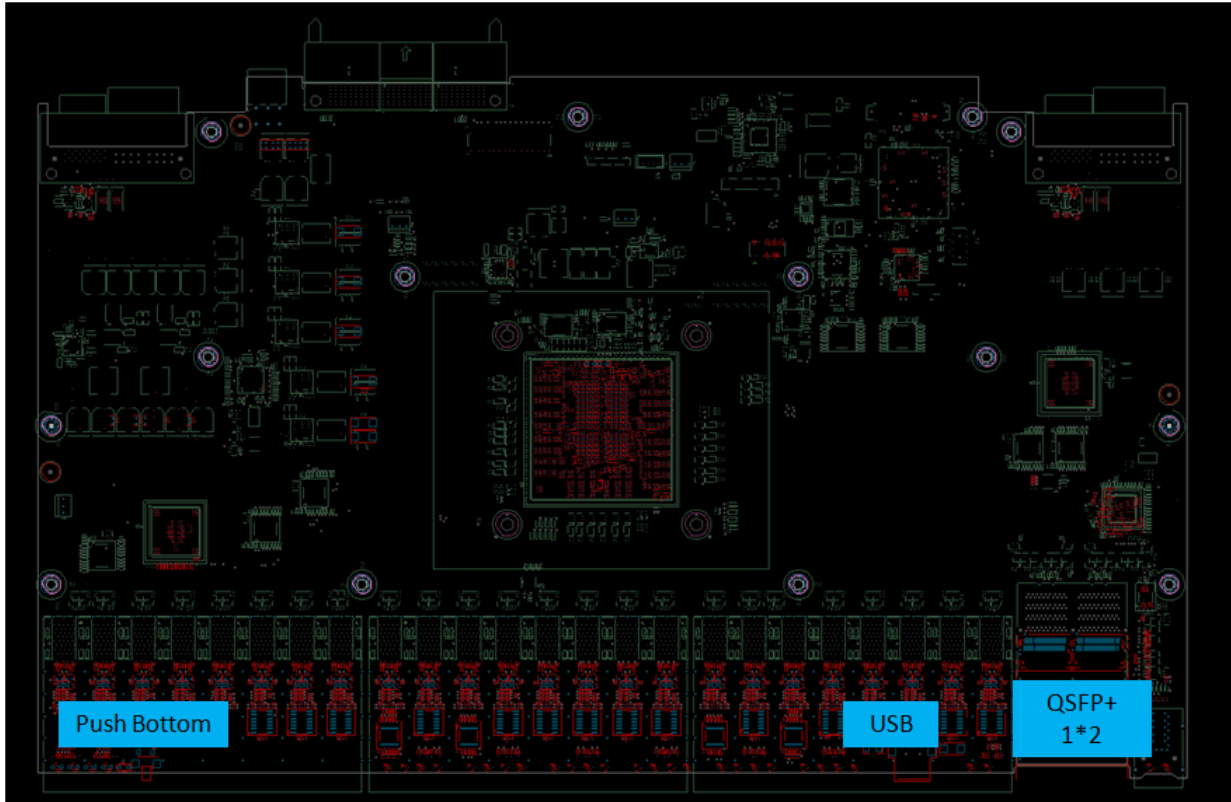

Fan PCB

The Fan PCB is 4 layers and provides the power, management and connectivity for the 5 system fan modules. The Fan PCB connects to the Main Switch PCB via a small cable assembly for power and a small cable assembly for management signals.

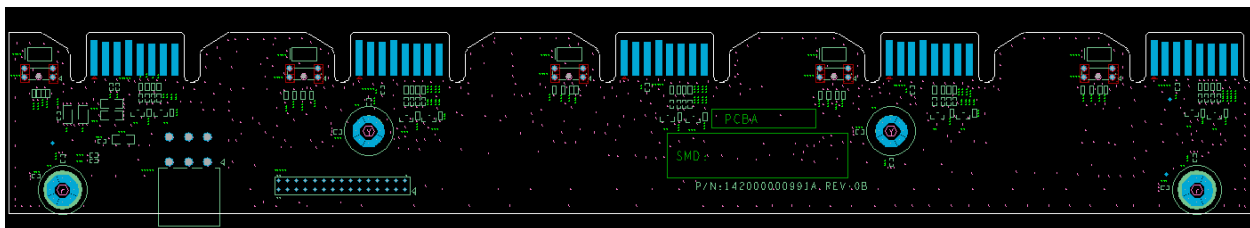

Fan PCB Dimensions

	Inches	Millimeters
Length	10.86	275.75
Width	1.57	40

Fan Signal Cable

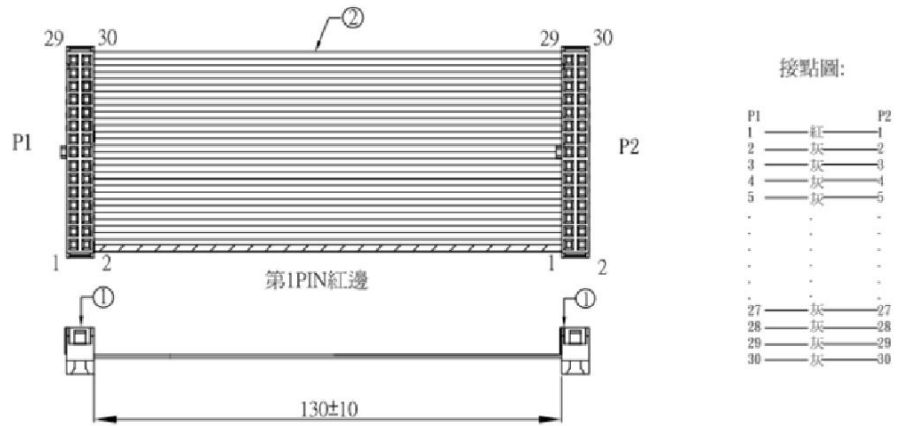

- Note:
1. 一般導通測試;
 2. Open/Short Test:100%;
 3. Conductor Resistance:2Ω (Max);
 4. Insulation Resistance:10MΩ (Min)
 5. 所有材料需符合RoHS標準.
 6. operating temperature range:-40°C-80°C
 7. Storage temperature:15°C-30°C

2	FLAT CABLE UL2651#28 30P PITCH=1.0MM 紅灰排	1	
1	IDC CONNECTOR 30P(2*15) SOCKET PITCH=2.0MM 二件式,有防呆	2	G/F
ITEM	DESCRIPTION	Q' TY	REMARK

CPU Module PCB

The CPU module is a 12 Layer PCB and supports the communication processor and associated components for the CPU subsystem. The communication processor utilized is an Intel Atom C2000 series communication processor. This family of Intel SoCs offers a wide range of pin compatible options scaling from two to eight cores, a thermal design power (TDP) of 7W to 20W, integrated HW acceleration, and Intel Xeon Instruction Set Architecture compatibility.

CPU PCB Top and Bottom side

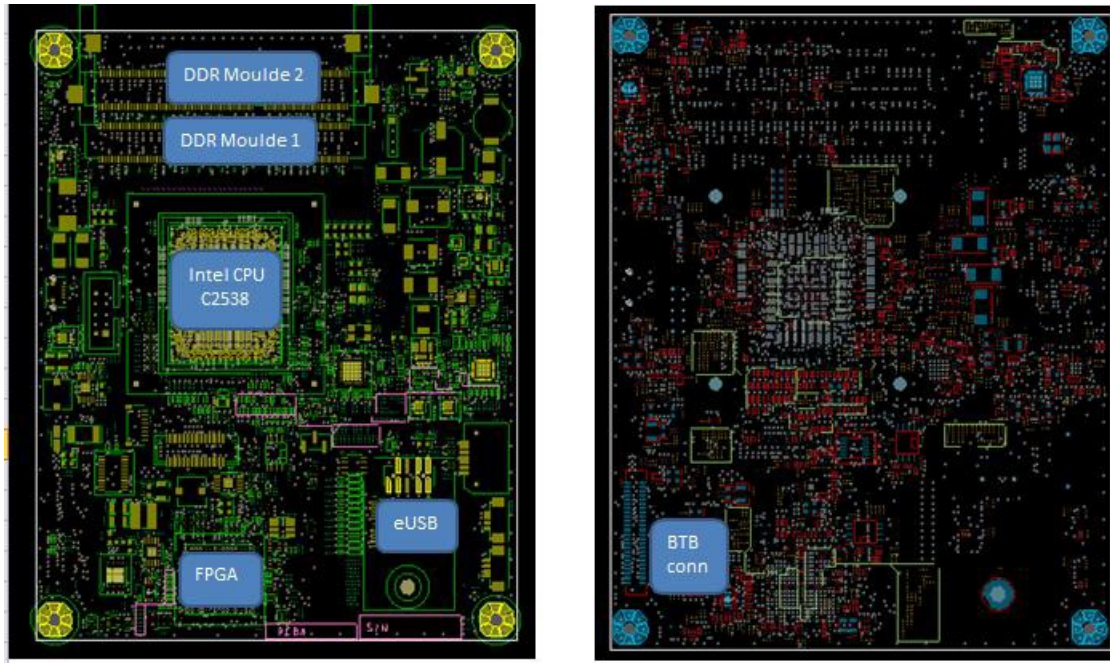

CPU PCB Dimensions

	Inches	Millimeters
Length	5.98	151.9
Width	4.83	122

CPU PCB major components

Description	Manufacturer	Part Number
CPU	Intel	C2538 – 2.4GHz 3.0V
SDRAM 4GB SO-DIMM w/ECC (x2)	Innodisk	M3D0-4GHS2LPC 4GB 1.35V
USB to NAND Flash 8GB	ATP	AF2GSSGH-A11
SPI NOR Flash 8MB (x2)	Winbound	W25Q64FVSSIG
Trusted Platform Module (TPM)	STMicroelectronics	ST33ZP24AR28PVSP ST
FPGA	Microsemi	A2F200M3F-1FGG256

Software Support

The NPS4806 supports a base software package composed of Open Source components.

BIOS support

The NPS4806 Supports Coreboot/SeaBios

ONIE

Support for ONIE

Open Network Linux

Support for ONL

Power/Environmental/Agency Certifications

Power Consumption

The total estimated system power consumption of the NPS4806 is ~360 Watts. This is based upon worst case power assumptions for traffic, optics used, and environmental conditions.

Environmental

- 0 to 40 Degrees C standard operating range
- -40 to 70 Degrees C storage
- Humidity 5% to 95% non-condensing
- Vibration – IEC 68-2-36, IEC 68-2-6
- Shock – IEC 68-2-29
- Acoustic Noise Level – Under 60dB in 40 degree C

Safety

The following safety item are planned to be certificated

- UL/ Canada
- CB (Issued by TUV/RH)
- China CCC

Electromagnetic Compatibility

The following EMC related item are planned to be certificated.

- CE
- EN55022 Class A
- EN55024
- EN61000-3-2
- EN61000-3-3
- FCC Title 47, Part 15, Subpart B Class A
- VCCI Class A
- CCC

ROHS

RoHS Requirement(Regulatory Standards Compliance table)		
#	Description	Limitation/ ppm
1	Cadmium/ Cadmium Compounds	80
2	Hexavalent Chromium/ Hexavalent Chromium Compounds	800
3	Lead/ Lead Compounds	800
4	Mercury/ Mercury Compounds	800
5	Polybrominated Biphenyls (PBBs)	800
6	Polybrominated Diphenylethers (PBDEs)	800