



OPEN

Compute Project

AT&T Single Port G.fast
Open DPU Specification
(ODPU-1P)

Revision 2.0

Authors: Mark Shostak, Sumithra Bhojan and Tom Anschutz

Acknowledgement

We would like to acknowledge the contribution and partnership of the Scipio team, led by Yaniv Lavi and Microsemi by Arkadiy Peker in development of this spec. Also, to our colleagues at AT&T and at the other Service Providers who provided invaluable insights into how the Open DPU could be used. Lastly, the OCP, without whose support and existence this type of work would not be possible.

-Mark, Sumithra & Tom

Revision History

Revision	Date	Author	Description
1.0	1/17/2017	Sumithra Bhojan, Mark Shostak	Initial Release
2.0	8/31/2017	Mark Shostak	Detailed design creation

Contents

Acknowledgement	2
Revision History	2
Contents	3
Licenses	4
Scope	4
Executive Summary	5
Overview	5
Indoor/Outdoor	7
Twisted Pair and Coax	7
Reverse Power	7
Software Stack	8
G.fast Network Application	9
Physical Overview	10
Dimensions	10
Front View	10
Panel LED Definitions	11
SFP Interface Module Support	12
Integrated ONT Interface Support	12
System Overview	13
High-Level Block Diagram	13
Key Components in the Block Diagram	13
Functional Hardware Blocks	14
Modem (FTU-O)	14
GPON Uplink	14
vBMC – Virtual Board Management Controller	15
Power Supply	15
RPF Power Conversion	16
Design Options	17
Uplink Interface	17
Wiring Adaptation	17
External RAM	17
Software Support	18
General Specifications	19
Power Consumption	19
Network Equipment and Power Grounding, Environmental, and Physical Design Requirements	20

Licenses

This specification is contributed under the OCP Contributor Licensing Agreement (OCP-CLA) by AT&T.

Limitations of the OCP CLA license are noted below:

All devices that may be referred to in this specification, or required to manufacture products described in this specification, will be considered referenced only, and no intellectual property rights embodied in or covering such devices shall be licensed as a result of this specification or such references. Notwithstanding anything to the contrary in the OCP-CLA, the licenses set forth therein do not apply to the intellectual property rights included in or related to the devices identified in this specification. For clarity, no patent claim that reads on such semiconductor devices will be considered a "Granted Claim" under the applicable OCP-CLA for this specification.

You can review the signed copies of the OCP-CLA for this specification on the OCP website. <http://www.opencompute.org/products/specsanddesign>

Usage of this specification is governed by the OCPHL permissive.

You can review this license at <http://www.opencompute.org/participate/legal-documents/>

Your use of this Specification may be subject to other third-party rights. THIS SPECIFICATION IS PROVIDED "AS IS." The contributors expressly disclaim any warranties (express, implied, or otherwise), including implied warranties of merchantability, non-infringement, fitness for a particular purpose, or title, related to the Specification. The entire risk as to implementing or otherwise using the Specification is assumed by the Specification implementer and user. IN NO EVENT WILL ANY PARTY BE LIABLE TO ANY OTHER PARTY FOR LOST PROFITS OR ANY FORM OF INDIRECT, SPECIAL, INCIDENTAL, OR CONSEQUENTIAL DAMAGES OF ANY CHARACTER FROM ANY CAUSES OF ACTION OF ANY KIND WITH RESPECT TO THIS SPECIFICATION OR ITS GOVERNING AGREEMENT, WHETHER BASED ON BREACH OF CONTRACT, TORT (INCLUDING NEGLIGENCE), OR OTHERWISE, AND WHETHER OR NOT THE OTHER PARTY HAS BEEN ADVISED OF THE POSSIBILITY OF SUCH DAMAGE

Scope

This document defines the technical specifications for the AT&T Single Port G.fast Open-DPU (ODPU-1P), submitted to the Open Compute Project.

Executive Summary

The Open DPU Single Port unit (ODPU-1P) is employed differently from typical DPU use cases, but similarly is intended to help address a few primary goals of a Service Provider's business:

- Increase Addressable Market and Top Line
- Reduce Cost to Improve Bottom Line
- Improve Customer Satisfaction and Reduce Churn

As competition in Access and the cost of capital grow, so does the need to acquire and retain as many customers as possible. FTTH offers well known advantages, but unfortunately there are some living units that are prohibitively expensive, or otherwise impractical to serve.

The device described herein is intended to help address situations where the SP has elected not to pull a fiber drop to a specific living unit, but there is existing copper (twisted pair or coax) in place. The ODPU-1P helps provide the SP an ability to leverage this copper to extend a fiber-like experience and turn up these subscribers, which otherwise would have to be turned away or served by a less competitive offering (e.g., VSDL2).

Design decisions have been made to minimize the cost, size and time required to install the ODPU-1P, to help improve the bottom line, as does salvaging qualified installs that would otherwise fail during the install process.

Finally, being able to serve these customers with a competitive offering helps the SP defend against competitors, in addition to the other values described above, which is why SPs may find themselves wanting to learn more about the ODPU-1P Solution.

Overview

This document describes the technical specifications of the AT&T Single Port G.fast Open-DPU (ODPU-1P).

The ODPU-1P is the smallest member of AT&T's Open DPU Family, yet differs from its larger siblings in several key aspects for some interesting reasons, which are described in this Specification. Most notably the ODPU-1P:

- Offers a Point-Solution for hard to reach customers
- Implements 106MHz G.fast
- Supports iDTA
- Single SKU supports Twisted Pair, Coax and RPF
- Incorporates a GPON integrated ONT (iONT)
- Employs a Virtual BMC

Point-Solution: The ODPU-1P can be used as a point-solution in an FTTH environment, where it may be impractical to pull a fiber drop all the way to the living unit. In this application, the ODPU can be thought of as a vehicle to "extend" the fiber, by way of other mediums which may already be present in infrastructure, notably UTP.

106MHz G.fast: ODPU-1P has the luxury of not having to contend with multiple G.fast loops in the same device, which enables it to provide an improved Quality of Experience (QoE), through iDTA. Additionally, the 106MHz chips are more mature, and hence lower cost, as ODPU-1P is considered a more cost sensitive device.

iDTA: As mentioned above, the ability to use iDTA improves the customer QoE of a 106MHz service. Note: The other Coax-based ODPUs Family members can also use iDTA.

iONT: ODPUs-1P incorporate a GPON ONT, which further helps to reduce the Solution cost.

Single SKU: The same ODPUs-1P has terminations for both UTP and Coax, and supports RPF Reverse Power

vBMC: An innovative Virtual BMC is implemented in place of the μ BMC, again due to BoM cost sensitivities.

The aforementioned facets are described in more detail, later in this Specification.

The ODPUs-1P is physically a self-contained unit, and not part of a rack or other larger chassis configuration. The single port ODPUs can provide up to 1Gbps (aggregate) of broadband service using a twisted pair or coaxial extension to a GPON network fiber via a 106MHz, G.fast loop and enables service providers to service living units where it is cost prohibitive and/or physically impractical to pull a new optical fiber for the last few hundred feet, and instead leverage existing copper inside wiring (IW).

The customer facing (U-O) G.fast ports on the ODPUs provide both a balanced termination for utilizing existing or new UTP wiring, and an unbalanced termination for utilizing existing or new shielded coaxial cable. This design allows system power to be supplied via the customer facing U-O port, called Reverse Power Feed (RPF), and thus allows the unit to be installed in locations where power is not available.

The ODPUs-1P is a high-performance access design focused on broadband deployments that support both symmetric and asymmetric speeds with a total bandwidth of 1Gbps, utilizing a 106 MHz G.fast engine. The ODPUs are fed using an optical uplink, attached via SFP supporting both Ethernet and PON technologies, or alternately via an integrated GPON ONT (iONT). The silicon used in the ODPUs provides high throughput at low cost, latency, and power.

While the base ODPUs-1P design is for 106MHz, the design can readily be extended to utilize a full 212MHz, with an upgrade to newer G.fast modems.

Indoor/Outdoor

ODPU-1P is designed for a compact outdoor enclosure, similar in form factor to existing SFU ONTs, for deployment on walls on the exterior or interior side of residential living units, or small businesses. The package shown emphasizes robust weather resistance and environmental robustness. Based on current technology, variants intended for indoor installation could be made roughly as small as a paperback book.



Figure 1 – Outdoor DPU

Twisted Pair and Coax

This variant of the AT&T ODPU Family supports both Twisted Pair and Coax wiring (on a single SKU), from the ODPU to the customer modem or residential gateway.

The ODPU-1P supports independent Dynamic Time Assignment (iDTA), whereby the TDD up-stream:down-stream ratio can be adjusted on the fly, as defined in ITU-T G.9701, Amendment 3. iDTA enables the Service Provider to deliver a quality of experience commensurate with that of a fully symmetrical residential service of that nearly equal to the aggregate bit rate.

Reverse Power

Reverse Power Feed (RPF) is one of various ODPU powering methods defined in TR-301. When operating in RPF mode, the ODPU receives its power from the customer premises via the copper lines between the CPE and the ODPU. Any back-up battery or UPS would be located at the customer premises. Reverse powering shall have two power splitters, one located at the customer premises and the other at the ODPU, enabling power to be inserted from the customer end of the loop and extracted at the ODPU. In the ODPU-1P design, the Network side power splitter is integrated into the ODPU, while the other can be integrated into the CPE/RG, or can be a discrete power inserter, placed in series with the CPE/RG.

Software Stack

Software to drive the AT&T ODPU-1P is based on same approach taken for the Open GPON and Open XGS-PON specifications. As shown in Figure 2, and moving from the bottom to the top of the figure, the ODPU has Firmware and a Driver that run on the embedded silicon and exposes a management interface towards a standard G.fast management agent called a Persistent Management Agent (PMA). Each PMA manages a single ODPU. An additional software component external to the PMA is used to aggregate the Northbound interfaces of multiple PMAs, providing a single common Northbound interface for the entire group of PMAs. This aggregation component is referred to as the PMA Aggregator (PMAA). In the software stack, we will develop an open PMA with integrated Aggregation.

The ON.Lab VOLTHA project is an Open, multi-protocol management and control plane agent, and can be used to expose OpenFlow, as well as NETCONF interfaces to the control plane applications and configuration controllers. From these interfaces upwards, applications previously developed for GPON and XGS-PON can be reused for configuration and control of the G.fast Broadband Access Solution. This re-use of the networking stack is strategic, as GPON and XGS-PON are popular technologies for backhauling G.fast (O)DPUs.

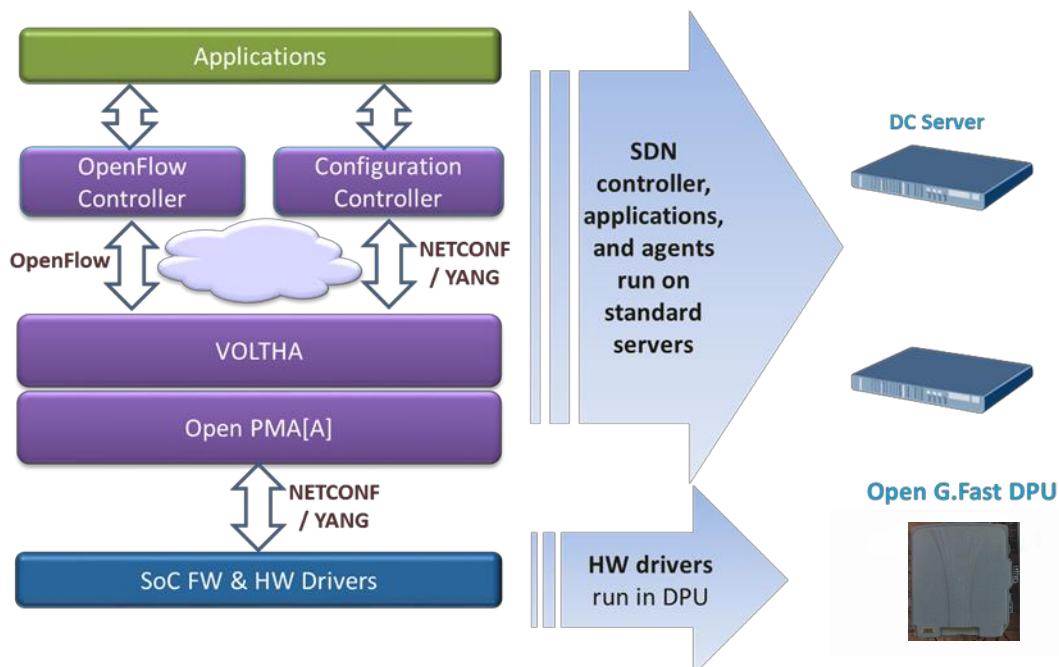

Figure 2 - Software stack for Open 16-Port G.fast DPU

To support this application, the ODPU-1P minimizes the number of components populated on the system board and leverages external, scalable, available and re-usable components instead.

This is the most basic and economic instantiation of this software architecture. Management is performed by external processes and communication is through a virtual LAN that isolates management traffic from subscriber bearer traffic. Specifically, there is a need to support an OOB (Out of Band) management LAN. The design supports a variety of power supply options and a virtual Board Management Controller (vBMC) to supervise ODPU-1P resources.

G.fast Network Application

A G.fast Access Network supports customers of various types, including those residing in both single and multi-family dwelling units. A novel and key feature of G.fast is the ability to Reverse-Power the ODPU from the attached customer port. This allows “extending fiber” with ODPU-1P from locations where local powering is difficult.

G.fast Access technology is typically deployed using twisted pair or coax loops that are less than ~250m, and which support roughly a gigabit of bandwidth when both directions are added up. The split of bandwidth used for upstream and downstream is configurable, and can be symmetric (e.g. 500x500M) or can be asymmetric (e.g. 750Mx250M).

Physical Overview

Dimensions

Dimension	Inches	Millimeters	Comments
Length –	~15.0	~381	
Width –	~10.5	~267	
Depth –	~7.0	~178	Inclusive of 50 foot fiber slack storage tray

Front View

Shown below is a generic Corning outdoor rated small equipment enclosure, suitable for housing apparatus of the ODPU-1P's class. This enclosure is pictured primarily for reference purposes, as the ODPU-1P will be capable of mounting in smaller enclosures, particularly if it can be installed indoors, where it is shielded from direct exposure to sunlight, wind, rain, etc. Based on current technology, variants intended for indoor installation could be made roughly as small as a paperback book.

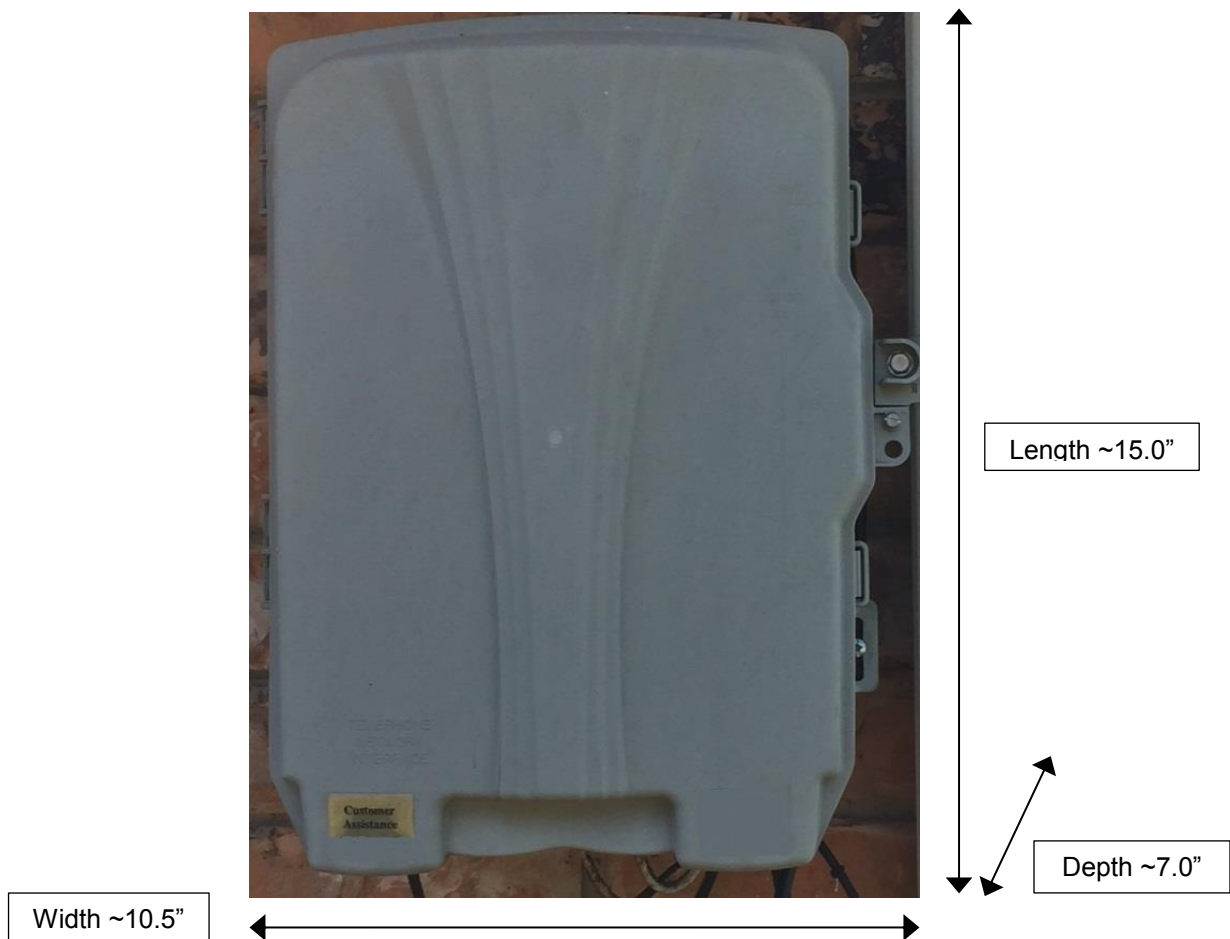

Figure 3: Front view of ODPU-1P

From a cabling perspective, the unit is merely requires interconnection:

- Fiber Uplink
- Twisted Pair Loop or Coaxial Cable
- Ground
- Optionally: Local Power

Panel LED Definitions

LED	Display	Interpretation
PWR	Off	Power is off
	else solid Green	System is receiving sufficient power
	else solid Yellow	System is receiving insufficient power (Note: For diagnosis purposes only; proper operation is not guaranteed with insufficient power)
NET	Off	Power is off
	else slowly Off/Red	system is booting
	else solid Red	No link to serving HON/Access Network (AN) <i>e.g. LOS on GE Uplink, no PON signal or no OMCI on GPON</i>
	else fast Red	<i>Future: Initialize DSL port for uplink in CPE mode</i>
	else solid Yellow	Connected to AN, running IP discovery (no valid IP address available)
	else slowly Off/Yellow	Connected to AN, valid IP available, connecting to PMA
	else solid Green	Connected to and established management link, with PMA
CUST	Off	Subscriber line port disabled
	else slowly Off/Green	Subscriber line is administratively enabled, but not operational no fault conditions, no test mode <i>(incl. in case of CPE mode uplink - future requirement)</i>
	else solid Green	Subscriber line is Operational no fault conditions, no test mode <i>(incl. in case of CPE mode uplink - future requirement)</i>
	else solid Red	Subscriber administratively enabled, but a fault condition is present <i>(incl. in case of CPE mode uplink - future requirement)</i> <i>This shall override any other state of this LED except the test mode.</i>
	else solid Yellow	The subscriber line is in test mode (SELT/DELT/MELT) <i>This shall override any other state of this LED.</i>

SFP Interface Module Support

Ethernet SFP Transceiver Modules	A standard 1Gb or 2.5Gb Ethernet module
GPON SFP ONT Modules	A standard 2.5Gb GPON SFP ONT module
XGS SFP ONT Modules	XGS SFP ONTs which implement SGMII, as well as XFI can be employed in ODP-1P

Integrated ONT Interface Support

APC terminated, integrated ONT (iONT)	A standard 1.24x2.5Gb G-PON ONT, utilizing an Open OMCI based management stack
---------------------------------------	--

System Overview

High-Level Block Diagram

A high-level diagram illustrating the major functional blocks and primary signal flows of the ODPU-1P is depicted in Figure 4.

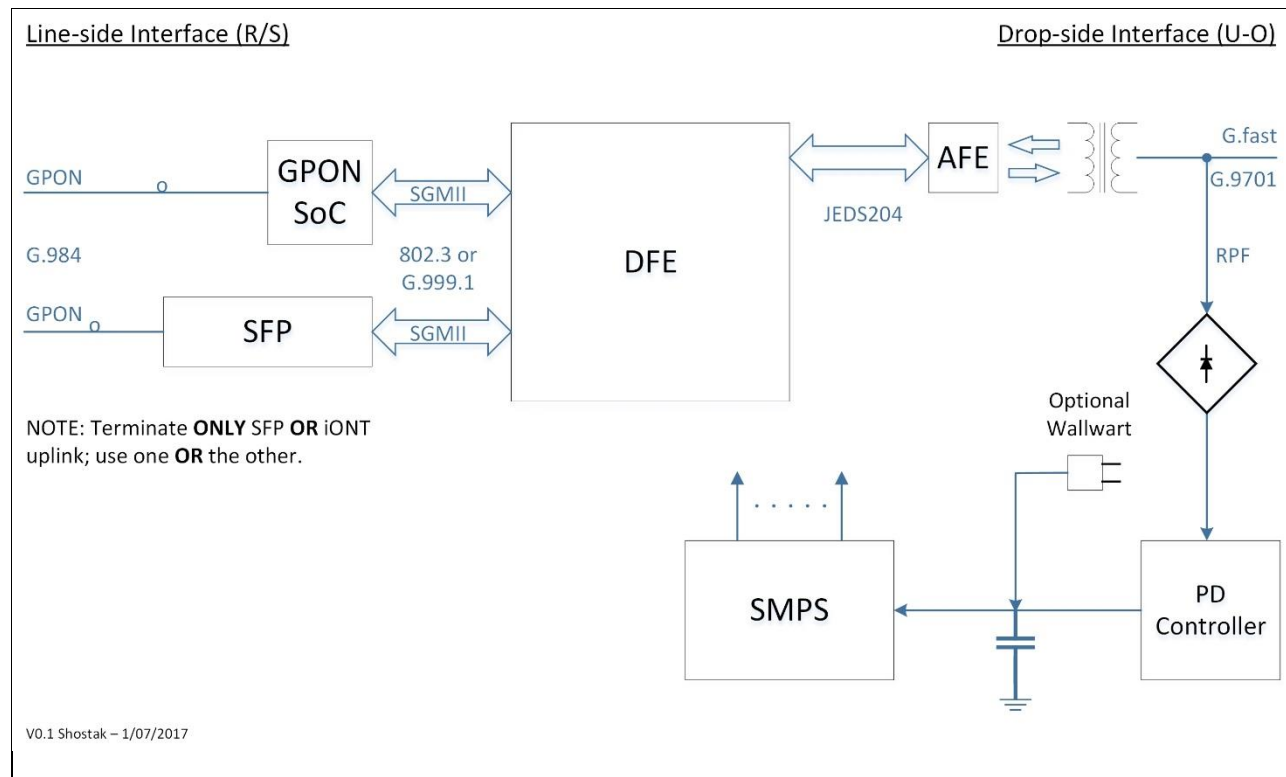

Figure 4 – High-Level Block Diagram

Key Components in the Block Diagram

- One SFP for optical uplink
- Alternately, one [integrated] iONT for GPON optical uplink
- A GPON SoC to terminate GPON fiber and provide Traffic Management (TM) function
- A DFE AASP to support the G.fast digital signal processing
- An Analog Front End (AFE) chip to translate the G.fast signal between the digital and analog domains
- Reverse Power Feed Powered Device (PD) controller
- Magnetics and other passives to perform 2 to 4-wire conversion and band pass filtering
- SMPS to provide requisite power rails for system operation

Support for Uplink Connectivity Modes

The ODP-1P uplink connectivity and configuration architecture can support various uplink link modes which can be configured differently based on the desired uplink technology (e.g., Ethernet or GPON), and other Service Provider specific needs as required by the service Access Network. For example:

- For **1Gb** or **2.5Gb** Ethernet – A respectively rated Ethernet SFP transceiver
- For **2.5Gb** GPON utilizing Open OMCI – Direct fiber termination on the iONT APC connector
- For **2.5Gb** GPON when SFP-ONT economics are more favorable or when utilizing other OMCI variants – A GPON SFP-ONT available for the serving Access Network

Functional Hardware Blocks

The ODP-1P system consists of the following primary HW modules:

Modem (FTU-0)

The G.fast modem is comprised of two primary components, the DFE and the AFE/LD.

DFE – The Digital Front End (DFE) is the heart of the modem, and is responsible for all of the signal processing and “baseband” type functions, up to and including the Ethernet interface to the uplink.

AFE/LD – The Analog Front End (AFE) is digitally coupled to the DFE, and is primarily responsible for converting digital symbols from the DFE into electrical waveforms that are amplified by the Line Driver (LD) and emitted by the ODP-1P via the selected transmission medium, as well as receiving electrical waveforms from the transmission medium, converting them into their digital representations, and delivering them to the DFE for processing.

The DFE implements the majority of the layer 1 and 2 functionality described in the ITU-T G.fast specifications, and integrates a plethora of functions including DSP and host stored program control. The DFE is coupled to the Analog Front End (AFE) via the AFE Serial Interface (ASI), which is a JEDS204-like high-speed serial interface. In concert with the DFE, the two devices develop a G.fast compliant U-O interface, which can be magnetically coupled to a balanced UTP drop or an unbalanced coaxial drop, delivering gigabit class service to the subscriber.

GPON Uplink

The ODP-1P is intended to be served by a GPON or Ethernet uplink, and is coupled to the Access Network via a GPON SoC. With an integrated Microprocessor, Traffic Manager and other logic, the SoC provides and/or hosts a myriad of functions in support of the overall ODP-1P, such as:

- Reference Clock Delivery
- Virtual Board Management Control (vBMC)
- Ambient Temperature Reporting
- Execute system-level executive control program
- Execute the OMCI management stack
- Execute DFE driver software
- Execute a virtualized BMC (vBMC) application

The heart of the GPON Uplink is a single chip GPON SoC solution. This single chip is directly coupled to a laser (BOSA) on its drop side, and the DFE on its UNI side. All functionality required to manage the PON, send and receive data on the PON, and communicate with the DFE is contained within that one integrated circuit. The only notable external components are volatile and non-volatile memory devices. Further, it's still an open question whether the volatile memory (i.e. RAM) will be required in the production implementation. If it were feasible to remove it, it would help reduce cost and potentially increase reliability.

The GPON SoC is coupled to the DFE via an SGMII interface, capable of operating at either 1.25Gbps or 3.125Gbps. In the ODP-1P, the slower speed is fully capable of servicing the single G.fast subscriber, hence the slower speed will be used. Other applications which may require the additional bandwidth can select the higher speed without modification to this interconnection.

The design also provides an SFP receptacle, which, alternately can accept a suitable GPON ONT in an SFP form-factor (i.e. SFP-ONT). The SFP is coupled to the DFE via an SGMII operating at 1.25Gbps. The SFP receptacle can also accept a conventional Ethernet transceiver. As the ODP-1P's embedded Traffic Manager (TM) is not connected to the SFP interface, use cases employing the SFP for Ethernet, as well as SFP-ONTs that do not have integrated TM capability are relegated to operation in TR-301 Model 1 (TR-167) mode. The iONT, as well as SFP-ONTs with sufficient hardware and firmware capabilities may operate in Model 1 or Model 2 (TR-156) mode.

vBMC – Virtual Board Management Controller

The vBMC is functionally similar to the physical BMC found on Enterprise/DC grade servers, however, it has been adapted for the specific requirements and cost sensitivity of the ODP-1P application. The original intent of the BMC was to provide low-level hardware supervision for servers, so they could be reset, powered up, powered down, monitored, etc. irrespective of their state (e.g., on, off, hung, out-of-box, etc.) by a human from a remote location or by a programmatic executive over serial or IP connectivity.

As technology advanced, so has the BMC. Modern BMCs are capable of exporting devices such as video displays and keyboards (KVM over IP), as well as mass storage devices (e.g., DVD) and USB interfaces, all over IP. Unfortunately, the ODP-1P can't justify the cost of a BMC device. Fortunately, ODP-1P does not require the vast majority of a BMC's functionality, which opens the door to alternate implementations.

The ODP-1P solution is to "virtualize" the minimal required BMC functionality. Instead of being instantiated in a physical BMC chip, the functionality will be implemented in software, and instantiated in the GPON SoC. The GPON base and application software on the platform is mature enough, that it is believed it can be reliably leveraged to supervise the G.fast subsystems.

While this is a compromise approach, it offers the bulk of the desired functionality, at a price that can't be refused.

Power Supply

Two primary options are provided for powering ODP-1P, a Reverse Power Feed option and a local powering option. Within the ODP, a dual conversion approach is employed, where the first conversion stage normalizes the power source options, along with a capacitive holdover reservoir, to a single common supply rail (12VDC). Then, a second conversion stage develops the plethora of voltages required by the devices on the board, from the single normalized supply. This simplifies the overall power strategy, particularly system

holdover. Holdover provides the ability for the ODPU to continue to operate, and more importantly, not require a full cold start, following momentary interruptions in power from the primary power source, and is supporting a standards requirement.

The RPF implementation first employs a bridge rectifier, which is DC coupled to the U-O port through a low-pass filter, and enables the ODPU to be polarity insensitive to a tip and ring reversal in the IW, supporting a standards requirement. The polarity normalized current is then coupled to an 802.3af/at compliant Powered Device (PD) Controller. The PD Controller provides first stage conversion and qualification of the 0 to 57 Volts found on the U-O interface supplied by the subscriber's RPF equipment, to the ODPU's normalized 12V supply rail. The PD also manages the handshake between the ODPU and the subscriber's PSE, as well as supporting multiple standards requirements. The ODPU is an 802.3at Type 1 application.

The optional local power configuration merely couples a 12V DC 3.5mm coaxial power input (aka "barrel jack") to the ODPU's normalized 12V supply rail by way of a blocking diode, which prevents back-feeding of current out of the ODPU-1P. The jack is intended to be connected to a mains powered, outlet receptacle mounted, conversion device (aka "Wallwart" or "AC Adapter"), which performs the primary power conversion from the mains supply (e.g., 100V, 120V, 220V, etc.) of the local region of the installation, to the normalized 12V DC rail. This power adapter must provide registered compliance with all locale-specific safety requirements, and would be of the commoditized variety utilized by typical consumer electronic devices.

You must consult your local legal, electrical and other relevant experts to ensure compliance with all applicable governmental and corporate regulations.

An alternative local power option is to use the traditional GPON PSU, with or without a BBU.

An internal power "reservoir" comprised of one or more capacitors, is also connected to the normalized supply rail, and under normal circumstances is kept fully charged by ingesting power from the rail. In the event of a momentary interruption in primary power, this holdover supply will source power into the normalized supply rail, thereby assuring continued operation of the secondary power conversion stage, and hence all of the critical devices within the ODPU. Upon restoration of primary power, the reservoir will begin to recharge to be ready for a future power interruption. As long as a primary power source is reenergized before the reservoir is depleted, the ODPU will continue to operate normally. This is in support of a standards requirement.

RPF Power Conversion

The Reverse Power Feed (RPF) subsystem depicted in Figure 5 performs reverse power start-up detection, classification and handshaking and front-end power conversion, and consists of following blocks:

- Surge protection circuitry
- Low pass filter, which provides separation of power and GFAST data
- Steering diodes to provide RPF polarity insensitivity
- PD70X01 Powered Device (PD) controller to perform power feed detection and classification, compliant with ETSI TS 101548 requirements
- DC/DC power conversion from RPF voltage on the U-O input of the ODPU to a nominal 12V

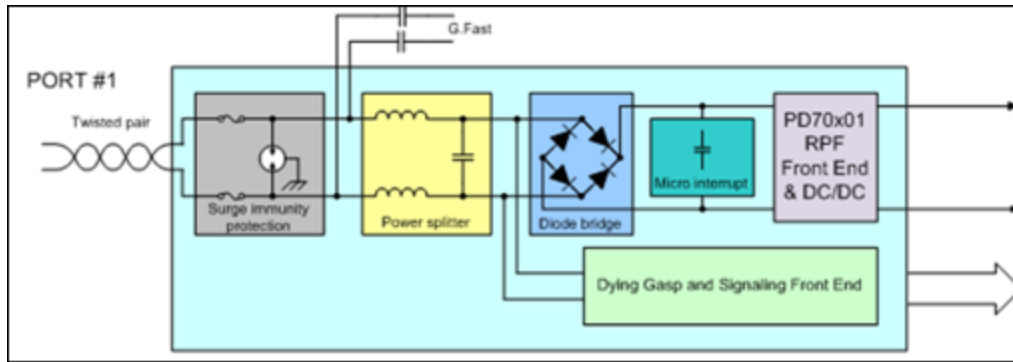

Figure 5 – RPF PD Controller Block Diagram

Design Options

Uplink Interface

As previously discussed, the ODPU-1P design features an SFP-based uplink, as well as an integrated iONT. However, only one of the two uplinks is required to serve the subscriber at the gigabit rate, as supported in this design. Further, it is believed that in practice, a Service Provider's Access Network will only support/or require one interface mode. Therefore, it is conceivable that depopulation of one of the interfaces would be a viable option to reduce costs. However, at the time of writing there is insufficient data to eliminate either of the options. It is envisioned that the uplink depopulation option is something that would be exercised at some time in the future, while the design is undergoing a re-spin for cost improvement purposes, and Service Providers have registered their preference in this area.

Wiring Adaptation

Unlike its siblings in the AT&T ODPU Family, the ODPU-1P integrates Wiring Adaptation (WA) for both the balanced UTP and unbalanced coaxial terminations, as well as for RPF on the same SKU without need for WA optionality modules. This vastly simplifies the overall Solution from manufacturing, to Supply Chain, to Craftsperson installation, maintenance and probability of error or premature failure. ODPU-1P does this for the marginal cost of the duplicated magnetics, passives and extra connector on the side of the housing. It's a veritable bargain.

External RAM

Certain ODPU-1P use cases can be implemented without equipping the GPON SoC with external RAM. While this option can reduce cost to some extent, and potentially increase reliability, it limits the flexibility of the ODPU-1P in that many features cannot be implemented without the additional memory. For example, use of the Linux OS requires the memory. Hence, any software dependent on Linux requires the memory. Therefore, if considering exercising this option, all of the implications should be carefully evaluated.

Software Support

The ODPU-1P supports Application software composed of the primary modules described above, in the Section identified as “GPON Uplink”.

The ODPU-1P reuses the VOLTHA Cloud-based Access platform, and embeds the software and architecture illustrated in Figure 6, including the following key components described below.

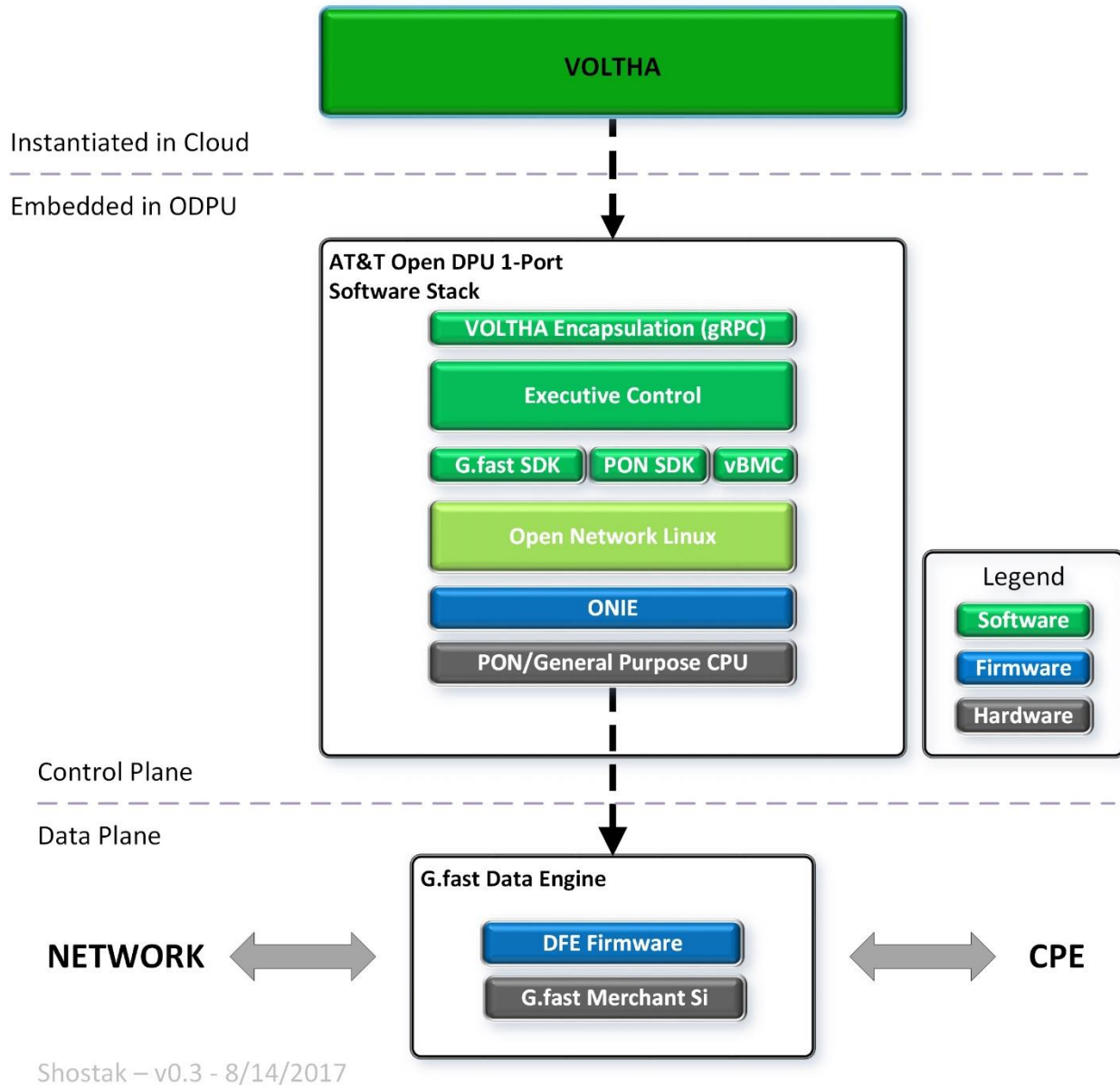

Figure 6 – ODPU-1P Software Stack

Cloud Resident Software

- VOLTHA – ON.Lab Open, Cloud-based virtualized Access platform

ODPU Embedded Host Software

- **Executive Control:** The primary Application with the ODPU-1P; coordinates all activity within the device
- **G.fast SDK:** The software library responsible for exposing the user (developer) API to the G.fast engine
- **GPON SDK:** The software library and Application responsible for establishment and supervision of communications over the PON
- **VOLTHA Encapsulation:** Software responsible for sending and receiving messages to VOLTHA via gRPC
- **vBMC:** A software implementation of the supervisory functions offered by a BMC or μ BMC
- **Open Network Linux:** ONL is a Linux variant specifically optimized for use in network devices built from commodity components
- **ONIE:** A pre-boot environment enabling automated operating system provisioning

G.fast Data Engine (Modem)

- **DSP Firmware:** Embedded firmware responsible for operating the G.fast modem

Refer to <http://opencord.org/> for information and documentation.

General Specifications

Power Consumption

The total estimated system power consumption of the AT&T Single Port G.fast Open-DPU is targeted to be less than 15 Watts for an active ODPU-1P at the FTU-O interface. This is based upon worst case power assumptions for traffic, optics used, and environmental conditions. Losses in power conversion at various stages need to be considered while designing the ODPU. The estimate for the single port power consumption is based on an SR3 class Reverse Power Injector (RPI) at the CPE and a deployment distance < 200m.

The table below shows the estimated typical power consumption of the OFPU-1P.

ODPU-1P	Twisted Pair ODPU Single Port	Coax ODPU Single Port	Worst Case Power Available at FTU-O Termination
Active Ports	1	1	1
Nominal Power Consumption	<10.0 W	<10.0 W	15.0 W

Network Equipment and Power Grounding, Environmental, and Physical Design Requirements

Equipment must demonstrate conformance to subsets of requirements contained in **ATT-TP-76200** depending on the intended application and deployment location(s) of the equipment.

The requirements contained in ATT-TP-76200 apply to equipment systems and assemblies intended for installation in all AT&T network equipment spaces, including, electronic equipment enclosures such as controlled environmental vaults, outside electronic equipment cabinets, and customer locations.

Copies of this document and general information about AT&T's environmental equipment standards can be found at <https://ebiznet.sbc.com/sbcnebs/>.

The ODPU-1P and its power supplies must be listed by a Nationally Recognized Laboratory in accordance with the National Electrical Code, ANSI/NFPA 70.

The ODPU-1P must be capable of operating and starting at ambient temperatures from -40 to +65C, and from 5% to 95% relative humidity, non-condensing.

The optical power levels of the ODPU-1P's transmitter must not exceed the Class 1 limits specified in IEC-60825-1, Am. 2, "Safety of laser products - Part 1: Equipment classification, requirements and user's guide", and a label indicating "CLASS 1 LASER PRODUCT" shall be affixed to the unit.

The ODPU-1P fiber connector interface shall be an SC/APC type optical connector that meets the requirements of GR-326, and has a maximum insertion loss of 0.50 dB, a reflectance of -65 dB or better, and is angled.

The Coaxial and Ethernet ports must have a minimum of 6 kV of protection, and 12 kV if practical.