



OPEN

Compute Project

2000W AC Power Supply

Revision 01

1. License (**OCP CLA Option**)

Contributions to this Specification are made under the terms and conditions set forth in Open Compute Project Contribution License Agreement (“OCP CLA”) (“Contribution License”) by:

Flextronics Power Systems

Usage of this Specification is governed by the terms and conditions set forth in **Open Compute Project Hardware License – Permissive (“OCPHL Permissive”), (“Specification License”)**.

Note: The following clarifications, which distinguish technology licensed in the Contribution License and/or Specification License from those technologies merely referenced (but not licensed), were accepted by the Incubation Committee of the OCP:

NOTWITHSTANDING THE FOREGOING LICENSES, THIS SPECIFICATION IS PROVIDED BY OCP "AS IS" AND OCP EXPRESSLY DISCLAIMS ANY WARRANTIES (EXPRESS, IMPLIED, OR OTHERWISE), INCLUDING IMPLIED WARRANTIES OF MERCHANTABILITY, NON-INFRINGEMENT, FITNESS FOR A PARTICULAR PURPOSE, OR TITLE, RELATED TO THE SPECIFICATION. NOTICE IS HEREBY GIVEN, THAT OTHER RIGHTS NOT GRANTED AS SET FORTH ABOVE, INCLUDING WITHOUT LIMITATION, RIGHTS OF THIRD PARTIES WHO DID NOT EXECUTE THE ABOVE LICENSES, MAY BE IMPLICATED BY THE IMPLEMENTATION OF OR COMPLIANCE WITH THIS SPECIFICATION. OCP IS NOT RESPONSIBLE FOR IDENTIFYING RIGHTS FOR WHICH A LICENSE MAY BE REQUIRED IN ORDER TO IMPLEMENT THIS SPECIFICATION. THE ENTIRE RISK AS TO IMPLEMENTING OR OTHERWISE USING THE SPECIFICATION IS ASSUMED BY YOU. IN NO EVENT WILL OCP BE LIABLE TO YOU FOR ANY MONETARY DAMAGES WITH RESPECT TO ANY CLAIMS RELATED TO, OR ARISING OUT OF YOUR USE OF THIS SPECIFICATION, INCLUDING BUT NOT LIMITED TO ANY LIABILITY FOR LOST PROFITS OR ANY CONSEQUENTIAL, INCIDENTAL, INDIRECT, SPECIAL OR PUNITIVE DAMAGES OF ANY CHARACTER FROM ANY CAUSES OF ACTION OF ANY KIND WITH RESPECT TO THIS SPECIFICATION, WHETHER BASED ON BREACH OF CONTRACT, TORT (INCLUDING NEGLIGENCE), OR OTHERWISE, AND EVEN IF OCP HAS BEEN ADVISED OF THE POSSIBILITY OF SUCH DAMAGES

Table of Contents

1.	LICENSE (OCP CLA OPTION).....	2
	TABLE OF CONTENTS.....	3
2.	SCOPE & OVERVIEW	6
3.	MECHANICAL OVERVIEW	6
3.1	DC Output Connector	7
3.2	Handle Retention	8
3.3	LED Marking and Identification	8
3.4	Acoustic Requirements.....	9
3.5	Fan and Fan Speed Control Requirements.....	9
3.6	Thermal Sensors and OTP.....	10
4.	AC INPUT REQUIREMENTS	11
4.1	Power Factor and iTHD.....	11
4.2	AC Inlet Connector	11
4.3	AC Input Voltage Specification	12
4.4	AC Line Isolation Requirements.....	12
4.5	AC Line Holdup/Dropout	13
4.6	AC Line Fuse	13
4.7	AC Inrush.....	14
5.	EFFICIENCY	14
6.	DC OUTPUT SPECIFICATION	14
6.1	Output Power / Currents.....	14
6.2	Voltage Regulation	15

6.3	Dynamic Loading	16
6.4	Capacitive Loading	16
6.5	Hot Swap Requirements	16
6.6	Load Sharing	16
6.7	Ripple / Noise	17
6.8	Timing Requirements	17
7.	PROTECTION CIRCUITS	19
7.1	Over Current Protection & Short Circuit Protection (OCP & SCP)	19
7.2	Over Voltage Protection (OVP)	21
7.3	Under Voltage Protection (UVP)	21
7.4	Over Temperature Protection (OTP)	21
8.	CONTROL AND INDICATOR FUNCTIONS	22
8.1	PSON# Input Signal	22
8.2	PWOK (Power OK) Output Signal	22
8.3	SMBAAlert# Signal	23
8.4	PRESENT_L OUTPUT	23
8.5	12V Remote Sense	24
8.6	Hot Standby Operation	24
9.	ENVIRONMENTAL REQUIREMENTS	25
9.1	Temperature	25
9.2	Humidity	26
9.3	Altitude	26
9.4	Mechanical Shock	27
9.5	Vibration	27

9.6	Thermal Shock (Shipping)	27
10.	FIRMWARE REQUIREMENTS	27
10.1	PMBus	27
10.2	Power Reporting Accuracy	27
10.3	Summary of SMBus/PMBus Commands	28
10.4	Supports Operation With and Without PEC	30
11.	RELIABILITY	31
11.1	Component De-rating	31
11.2	Life Requirement	31
11.3	Mean Time Between Failures (MTBF)	31
12.	ECOLOGY REQUIREMENTS	31
13.	REGULATORY REQUIREMENTS	32
13.1	Product Safety Compliance	32
13.2	Product EMC Compliance – Class A Compliance	32
13.3	NEBS Compliance	33

2. Scope & Overview

This specification defines requirements for Open Compute Project Power Supply for AC2000W supporting server systems. This is a 2000W power supply with 12V main output and 12V standby output.

FPS-S-2000ADU00-102 is a normal airflow (from output connector to AC input connector) 2000 Watt AC to DC power supply.

FPS-S-2000ADU00-202 is a reverse airflow (from AC input connector to output connector) 2000 Watt AC to DC power supply.

3. Mechanical Overview

The physical size of the power supply enclosure is defined below. The power supply contains a single rotor 40mm fan. The power supply has a card edge output connector that interfaces with connector in the system. The AC plugs directly into the external face of the power supply. Refer to the mechanical drawing below.

Dimensions	40mm x 73.5mm x 265mm (H x W x D)
Output connector	Card edge compatible with FCI (10130248-005LF) or equivalent

Detailed mechanical drawing as follows

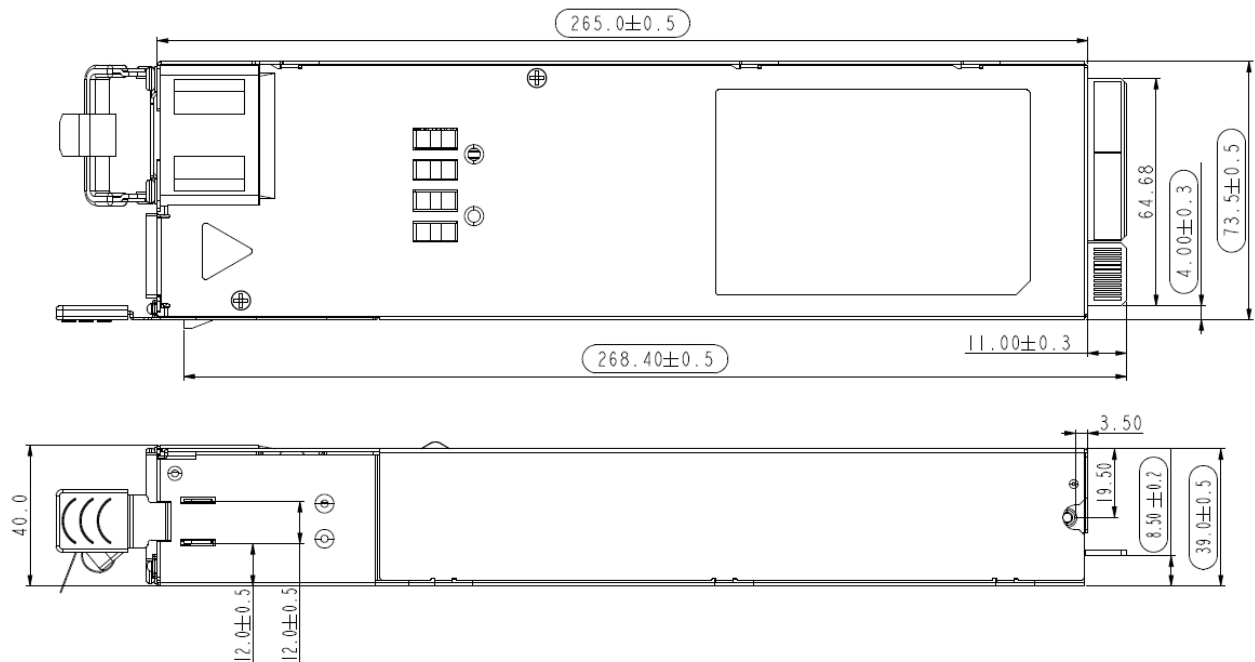

Figure 1 Power Supply Outline Drawing

Output the card edge connector gold finger drawing

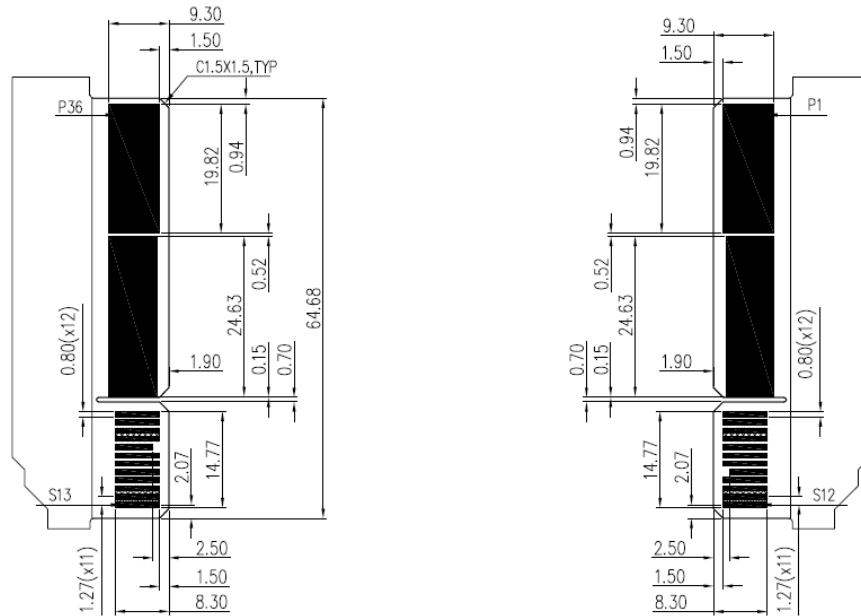
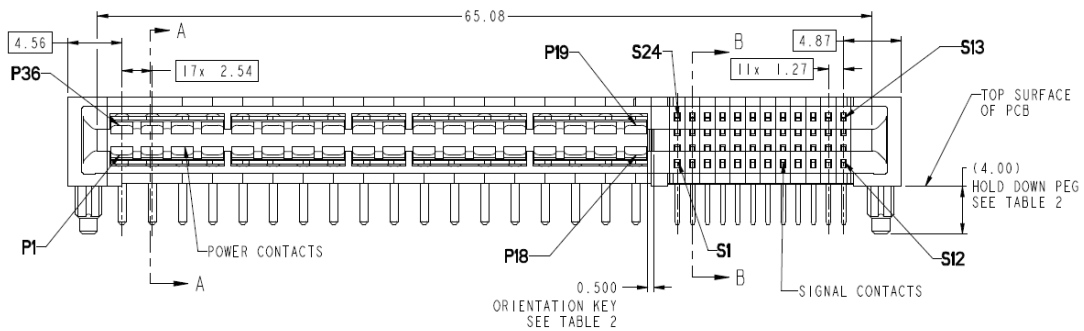

Figure 2 Detail Drawing

3.1 DC Output Connector

The power supply card edge pinout is defined in the table below. This card edge is compatible with FCI Connector(10130248-005LF) or equivalent.



Pin	Name	Pin	Name
P1	GND	P36	GND
P2	GND	P35	GND
P3	GND	P34	GND
P4	GND	P33	GND
P5	GND	P32	GND
P6	GND	P31	GND
P7	GND	P30	GND
P8	GND	P29	GND

P9	GND		P28	+12V
P10	GND		P27	+12V
P11	+12V		P26	+12V
P12	+12V		P25	+12V
P13	+12V		P24	+12V
P14	+12V		P23	+12V
P15	+12V		P22	+12V
P16	+12V		P21	+12V
P17	+12V		P20	+12V
P18	+12V		P19	+12V
S1	A0 (SMBus address)		S24	SDA
S2	A1 (SMBus address)		S23	SCL
S3	12V stby		S22	12V stby
S4	12V stby		S21	12V stby
S5	HOTSTANDBYEN_H		S20	PSOEN#
S6	12V load share bus		S19	SMBAlert#
S7	Reserved		S18	Return Sense
S8	PRESENT_L		S17	+12V remote Sense
S9	A2 (SMBus address)		S16	PWOK
S10	GND		S15	GND
S11	GND		S14	GND
S12	GND		S13	GND

3.2 Handle Retention

The power supply has a handle to assist extraction and can be inserted and extracted without the assistance of tools. The power supply also has a latch which retains the power supply into the system and prevents the power supply from being inserted or extracted from the system. The handle protects the operator from any burn hazard.

3.3 LED Marking and Identification

The power supply is designed with a bi-color LED; Amber & Green.

Table 1 LED State

Power Supply Condition	LED State
Output ON and OK	GREEN
No AC power to all power supplies	OFF
PSU in standby state AC present / Only 12VSB on	1Hz Blinking GREEN
Power supply in Hot-Standby state	1Hz Blinking GREEN
AC cord unplugged, or AC power lost; with a second power supply in parallel with AC input power.	AMBER
Power supply critical event causing a shutdown; failure, over current, short circuit, over voltage, fan failure, over temperature	AMBER
Power supply warning events where the power supply continues to operate; high temp, high power, high current, slow fan.	1Hz Blinking Amber
Power supply firmware updating	2Hz Blinking GREEN

Design note: LED is controlled by firmware to allow for a change to the blink rates and color to the above states by an update to the PSU secondary side firmware. This allows the PSU to be reprogrammed to match different customers' LED state requirements.

3.4 Acoustic Requirements

The power supply incorporates a variable speed fan. The declared sound power levels of the power supply meet the requirements shown in the table below. Sound power is measured according to ECMA 74 (www.ecma-international.org) and ISO7779, reported according to ISO 9296.

The ambient temperature listed in Table 2 is the inlet temperature to the power supply.

Table 2 Sound Power Requirement

Inlet Temperature Condition	% of Maximum Loading Condition	Declared Sound Power
25°C	50%	65 dBA

3.5 Fan and Fan Speed Control Requirements

The power supply incorporates a single rotor, 40mm fan for cooling the power supply.

When installed in the system, the airflow direction is defined below:

Normal airflow: From output connector to the AC inlet connector. The latch button color is RED, and handle color is BLACK.

Reverse airflow: From the AC inlet connector to output connector. The latch button color is BLACK, and handle color is BLACK.

The Fan speed control has a closed loop algorithm based on both the loading condition and the ambient temperature (Inlet temperature), see below Table . Thus, ensuring the PSU fan will always ramp to maximum speed (30000 RPM typical) under any condition to protect the power supply from overheating.

Table 3 Fan Typical RPM control (normal airflow)

RPM	Outlet Input Air Ambient Temperature						
	25	30	35	40	45	50	55
0%	5000	5000	5000	5000	14000	18000	26000
10%	5700	5700	5700	5700	14000	18000	26000
20%	6400	6400	6400	6400	14000	18000	26000
30%	7100	7100	7100	10000	14000	18000	26000
40%	7800	7800	7800	12000	22000	26000	Max speed
50%	8500	8500	8500	14000	22000	26000	Max speed
60%	14000	14000	14000	18000	26000	26000	Max

							speed
70%	18000	18000	18000	18000	26000	26000	Max speed
80%	22000	22000	26000	26000	Max speed	Max speed	Max speed
90%	26000	26000	Max speed	Max speed	Max speed	Max speed	Max speed
100%	26000	26000	Max speed	Max speed	Max speed	Max speed	Max speed

Table 4 Fan Typical RPM control (reverse airflow)

RPM	AC Inlet Side Input Air Ambient Temperature						
	25	30	35	40	45	50	55
0%	5000	5000	14000	18000	Max speed	Max speed	Max speed
10%	5700	5700	14000	18000	Max speed	Max speed	Max speed
20%	6400	6400	14000	18000	Max speed	Max speed	Max speed
30%	7100	10000	14000	18000	Max speed	Max speed	Max speed
40%	7800	12000	22000	26000	Max speed	Max speed	Max speed
50%	8500	14000	22000	26000	Max speed	Max speed	Max speed
60%	14000	18000	26000	26000	Max speed	Max speed	Max speed
70%	18000	18000	26000	26000	Max speed	Max speed	Max speed
80%	26000	26000	Max speed	Max speed	Max speed	Max speed	Max speed
90%	Max speed	Max speed	Max speed	Max speed	Max speed	Max speed	Max speed
100%	Max speed	Max speed	Max speed	Max speed	Max speed	Max speed	Max speed

Note: When load changes, transition to the steady state fan speed shall take place within 60 seconds.

3.6 Thermal Sensors and OTP

The PSU has thermal sensors to measure inlet/outlet temperature and hot spot component temperatures. These are used for asserting the over temperature warning condition (OTW), over temperature protection/shutdown (OTP), reporting temperatures via PMBus, and for controlling the fan speed.

Accuracy of the ambient thermal sensors is +/-4°C. Over temperature warning condition (OTW) and over temperature protection/shutdown (OTP) levels are defined in Table 5 below.

Both the hotspot thermal sensor(s) and the ambient inlet thermal sensor shall have both OTW level and OTP level associated with them.

- A.** OTW: Over temperature warning level associated with all thermal sensors. This asserts the SMBAlert# signal and does not shut down the PSU. This also asserts the associated PMBus STATUS warning bits. This support the CLST (Closed Loop System Throttling) feature.
- B.** OTP: Over temperature protection level associated with all thermal sensors. This shuts down the PSU to protect any components from exceeding their maximum temperature. This also asserts the associate PMBus STATUS bits.

Table 5 Ambient Sensor Trip Typical Levels

	Reverse airflow	Normal airflow
Over temp warning, Amb Temp (OTW)	70°C	70°C
Over temp shutdown, Amb Temp (OTP)	74°C	74°C

Note: Internal fan speed control algorithm ramps the fan speed to the maximum prior to the SMBAlert insertion.

4. AC Input Requirements

4.1 Power Factor and iTHD

The power supply meets the power factor and current iTHD requirements below. These requirements are within the Energy Star® Program Requirements for Computer Servers.

Table 6 Power Factor Requirements

Output power	10% load	20% load	50% load	100% load
Power factor	> 0.90	> 0.96	>0.99	> 0.99

Table 7 iTHD Requirements ¹

Output power	> 5% & ≤ 10%	> 10% & < 20%	≥ 20%	≥ 40%	≥ 50%
Current iTHD	< 20%	< 15%	≤10%	≤8%	≤5%

Note 1: Tested at 230Vac, 50Hz

Tested according to Generalized Internal Power Supply Efficiency Testing Protocol Rev6.7. This is posted at <http://www.plugloadsolutions.com/80pluspowersupplies.aspx>

4.2 AC Inlet Connector

The AC input connector is an IEC 60320-C14 power inlet.

4.3 AC Input Voltage Specification

The power supply operates within all specified limits over the following input voltage range. Harmonic distortion of up to 10% of the rated line voltage will not cause the power supply to go out of specified limits. Application of an input voltage below 85VAC will not cause damage to the power supply, including a blown fuse.

Table 8 AC Input Voltage Range

PARAMETER	MIN	RATED	VMAX	Start Up AC	Power Off VAC
Voltage (110VAC)	90Vrms	100-127Vrms	140Vrms	85VAC +/- 4VAC	74VAC +/- 5VAC
Voltage (220VAC)	180Vrms	200-240Vrms	264Vrms		
Frequency	47Hz	50/60	63Hz		

4.3.1 240VDC Input Specification (China Certs only)

The power supply will operate normally with a 240VDC input.

- Operating range: 180VDC to 300VDC
- PMBus commands function normally
- Power timing requirements met during power cycling
- Output power requirements support for equivalent AC RMS input voltage
- LED functions correctly
- For slow input voltage ramp:

Table 7.2 DC Input Voltage Range

Parameter	Min	Nom	Max
DC Input Range (Vdc)	180	240	300
DC Turn on Voltage (Vdc)	173	176	179
DC Turn off Voltage (Vdc)	165	168	171
DC Input OVP (Vdc)	310	315	320
DC Input Recovery (Vdc)	300	305	310

4.4 AC Line Isolation Requirements

The power supply meets all safety agency requirements listed in section 12 for dielectric strength.

Table 9 Insulation and Electric Strength Testing

Parameters	DESCRIPTION / CONDITION	NOTES
Grade of Insulation	Input (L/N) to chassis (PE)	Basic
	Input (L/N) to output	Reinforced
	Output to chassis (PE)	None (Output connected to chassis)
Electrical Strength Test	Input to chassis (PE)	2500VDC
	Input to output (tested by manufacturer only)	4242VDC

4.5 AC Line Holdup/Dropout

The power supply meets the AC holdup requirement over rated AC voltages and frequencies. A dropout of the AC line for any duration will not cause damage to the power supply.

Table 10 AC Holdup

Loading during AC holdup	Holdup time
50% of max load	15msec
70% of max load	11msec
100% of max load	7msec

Table 11 AC DIP Requirement

AC Line Sag (10sec interval between each sagging)			
Duration	Sag	Input Voltage and Load	Performance Criteria
0 to 10ms	>95%	200Vac input and 70% load	No loss of function or performance
500ms	30%	200Vac input and 70% load	No loss of function or performance
5000ms	>95%	200Vac input and 70% load	Loss of function acceptable, self-recoverable

Note: This must be tested with a bulk capacitor having the minimum capacitance tolerance at worst case loading and at worst case AC voltage conditions.

4.5.1 AC Line 12VSB Holdup

The 12VSB output voltage will remain in regulation for a minimum of 70ms under full load (static or dynamic) after a loss of AC.

4.6 AC Line Fuse

The power supply has one single line fuse on the line (Hot) wire of the AC input. AC inrush current will not cause the AC line fuse to blow under any conditions.

4.7 AC Inrush

When input power is applied to the power supply, the initial current surge (the first current to charge the bulk capacitor) or spike of 5ms will not exceed 10A peak at cold start.

The power supply meets the inrush requirements for any rated AC voltage, during turn on at any phase of AC voltage. Inrush current caused by X capacitors or Y capacitors is not considered.

5. Efficiency

The power supply meets Platinum efficiency levels of www.80plus.com for 230V Internal power supplies.

The testing procedure, which conforms to the 80Plus testing method, is as follows:

- Efficiency measured at 230Vac/60Hz.
- Both the +12V and +12Vsb outputs are at the same percentage of their max load.
- The efficiency test does not include the losses of the PSU fan.
- The ambient temperature is between 18°C and 28°C.

The Power Supply will dwell at each specified set point for 15 minutes before efficiency is measured.

Table 12 Efficiency Requirement

Loading	100% of maximum	50% of maximum	20% of maximum	10% of maximum
Platinum efficiency	≥ 92%	≥ 94%	≥ 90%	≥88%

6. DC Output Specification

6.1 Output Power / Currents

The following tables define the minimum power and current ratings. The power supply meets both static and dynamic voltage regulation requirements for all conditions.

Table 13 Load Requirements

Output	Input Voltage (VAC)	Power 1 Max. (W)	Min. (A)	Max. Continuous (A)	Peak Current 20sec duration ² (A)	Pmax.app Peak 10msec duration ³ (A)	Pmax Peak 100µsec duration ⁴ (A)
12V main	90-140	1000	0.1	83	107	130	200
12V main	180-264	2000	0.1	167	202	258	298
12Vstby	90-264	42	0.05	3.5	4		

Notes:

1. Maximum continue output power for all outputs must not exceed 2000 W at high line and 1000W at low line.

2. The load can apply for 20 seconds at 202A level and 60 seconds at 167A level with 180Vac input, this cycle can be repeated to maintain the average power about 105% of rated power level at normal airflow 55°C and reverse airflow 45°C.
3. The load can apply for 10msec at 258A level and 90msec at 167A level with 180Vac input, this cycle can be repeated to maintain the average power about 105% of rated power level at normal airflow 55°C and reverse airflow 45°C. Applying a Pmax.app peak load must not trip the SMBAlert# signal. The PSU support this peak load for 5msec after SMBAlert# asserts.
4. The load can apply for 100µsec at 298A level and a duration at 167A level with 180Vac input, this cycle can be repeated to maintain the average power about 105% of rated power level at normal airflow 55°C and reverse airflow 45°C. Pmax peak can support based on PMAX Protection requirements that included added system 12V capacitors. Apply loading greater than Pmax.app load may trip the SMBAlert# signal for quickly throttling the processor and memory load.

Table 14 PMAX Protection Testing Conditions

Pmax Peak Load	Peak current	System capacitance	SMBAlert# timing	Peak load duration	Voltage undershoot
3576W	298A	12 x 1,500µF	< 20µsec	100µsec	-2% (11.172V)

6.2 Voltage Regulation

The power supply output voltages stay within the following voltage limits when operating at steady state, load transition state and dynamic loading conditions. The test capacitive load (table 16) for each PSU is required to hold regulation for PSU failures that occur during Hot standby mode PSU and hot swapping.

Table 15 Static Voltage Regulation Set Point

Output	Load	MIN	NOM	MAX	UNITS
+12V	50% of max load	+11.95	+12.00	+12.05	Vrms
+12VSB	50% of max load	+11.95	+12.00	+12.05	Vrms

Table 16 Voltage Regulation Limits

PARAMETER	MIN	NOM	MAX	UNITS
+12V	11.40	12.00	12.60	V
+12VSB	11.40	12.00	12.60	V

Table 17 Load Transition Voltage Regulation Limits

Output	Min Load	Δ Step Load Size	Load Slew Rate	Min Cap	dVout Max
+12V	5% of max load	50% of max load	0.5A/µs	2,200 µF	0.6V
+12VSB	5% of max load	50% of max load	0.5A/µs	0 µF	0.3V

Table 18 Load Regulation Limits

PARAMETER	MIN	NOM	MAX	UNITS
+12V	-83	-110	-138	mV
+12VSB	-144	-240	-330	mV

6.3 Dynamic Loading

The output voltages will remain within limits specified for the step loading and capacitive loading in the table below. The load transient repetition rate was tested between 50Hz and 5kHz at duty cycles ranging from 10%-90%. The load transient repetition rate is only a test specification. The Δ step load may occur anywhere within the Min load to the Max load conditions. The test capacitive load (Table 16) is required to hold regulation for PSU failures that occur during Hot standby mode and PSU hot swapping.

Table 19 Dynamic Load Requirements

Output	Min Load	Δ Step Load Size	Load Slew Rate	Capacitive Load
+12V	1A	60% of max load	0.5 A/ μ sec	2,200 μ F
+12VSB	0.1A	1.0A	0.5 A/ μ sec	100 μ F

6.4 Capacitive Loading

The power supply is stable and meets all requirements with the capacitive loading range referenced in Table 17.

Table 20 Capacitive Loading Conditions

Output	MIN	MAX	Units
+12VSB	0	3,100	μ F
+12V	0	30,000	μ F

6.5 Hot Swap Requirements

Hot swapping a power supply is the process of inserting and extracting a power supply from an operating power system. During this process the output voltages will remain within the limits with the capacitive load specified. The hot swap test may be conducted when the system is operating under static, dynamic, or zero loading conditions.

6.6 Load Sharing

The +12V output is designed with active load sharing. The 12VSB output has a voltage set point of +12.1V at 1.75A (50% of the max output current) and load share design based on the droop method with a typical droop voltage of 240mV \pm 10% from no load to full load.

Table 21 +12V Output Sharing Accuracy

+12V loading	Deviation from I_{tot} / N
0% - 100%	+/-4A

Table 22 +12Vsb Output Sharing Accuracy

+12Vsb loading	Deviation from Itot / N
50%	+/-1A

Note: Itot is the total output current, N is the PSU quantity.

Table 20 12V Load Share Bus Voltage +12V loading	Min.	Typ.	Max.	Unit
0%	-0.3	0	0.3	V
10%	0.6	0.8	1.0	V
20%	1.4	1.6	1.8	V
50%	3.8	4.0	4.2	V
100%	7.8	8.0	8.2	V
I1peak	8.84	9.14	9.44	V

Note: 100% load refers to 167A output.

6.7 Ripple / Noise

The maximum output ripple/noise of the power supply is defined in Table 21. This is measured over a bandwidth of 10Hz to 20MHz at the power supply output connector. A 10µF ceramic capacitor and a 0.1µF ceramic capacitor are placed in parallel with a 2200uF conductive polymer electrolytic capacitor at the measurement point of the 12V output. A 10µF ceramic capacitor is placed in parallel with a 0.1µF ceramic capacitor at the measurement point of the 12VSB output.

Table 23 Ripple and Noise

+12V main	+12VSB
120mVp-p	120mVp-p

6.8 Timing Requirements

Requirements for the power supply operation in Table22 refer to the power supply being turned on and off by two different methods; 1) via the AC input with PSON held low; 2) via the PSON signal with the AC input applied.

Table 24 Timing Requirements

Item	Description	Min	N o m	MAX	UNITS
T12V_rise	Output voltage rise time from 10% to 90% of normal regulation.	10		30	ms
T12Vsb_rise	Output voltage rise time from 10% to 90% of normal regulation.	10		30	ms

Toff_latch	This is the time the PSU must stay off when being powered off with loss of AC input. Both outputs must meet this OFF time; 1) whenever PWOK is de- asserted for the 12Vmain output; 2) whenever the 12Vstby output drops below regulation limits	500		1000	ms
Tsb_on_delay	Delay from AC being applied to 12VSBbeing within regulation.			1500	ms
Tac_on_delay	Delay from AC being applied to all output voltages being within regulation.			2500	ms
Tpwok_holdup	Delay from loss of AC to de-assertion of PWOK at 70% load max.	10			ms
T12Vmain_holdup	Time the 12Vmainoutput voltage stays within regulation after loss of AC (70% load max).	11			ms
Tpson_off_delay	Delay from PSON# de-asserted to power supply turning off	2	3	4	ms
Tpson_on_delay	Delay from PSON# active to output voltages within regulation limits.	20	35	50	ms
Tpson_pwok	Delay from PSON# deactivate to PWOK being de- asserted.		1	2	ms
Tpwok_on	Delay from output voltages within regulation limits to PWOK asserted at turn on.	100	150	200	ms
Tpwok_off	Delay from PWOK de-asserted to output voltages dropping out of regulation limits.	0.15			ms
Tpwok_low	Duration of PWOK being in the de-asserted state during an off/on cycle using AC or the PSON signal.	100			ms
Tsb_vout	Delay from 12VSBbeing in regulation to O/Ps being in regulation at AC turn on.	50		500	ms
T12VSB_holdup	Time the 12VSBoutput voltage stays within regulation after loss of AC.	70			ms

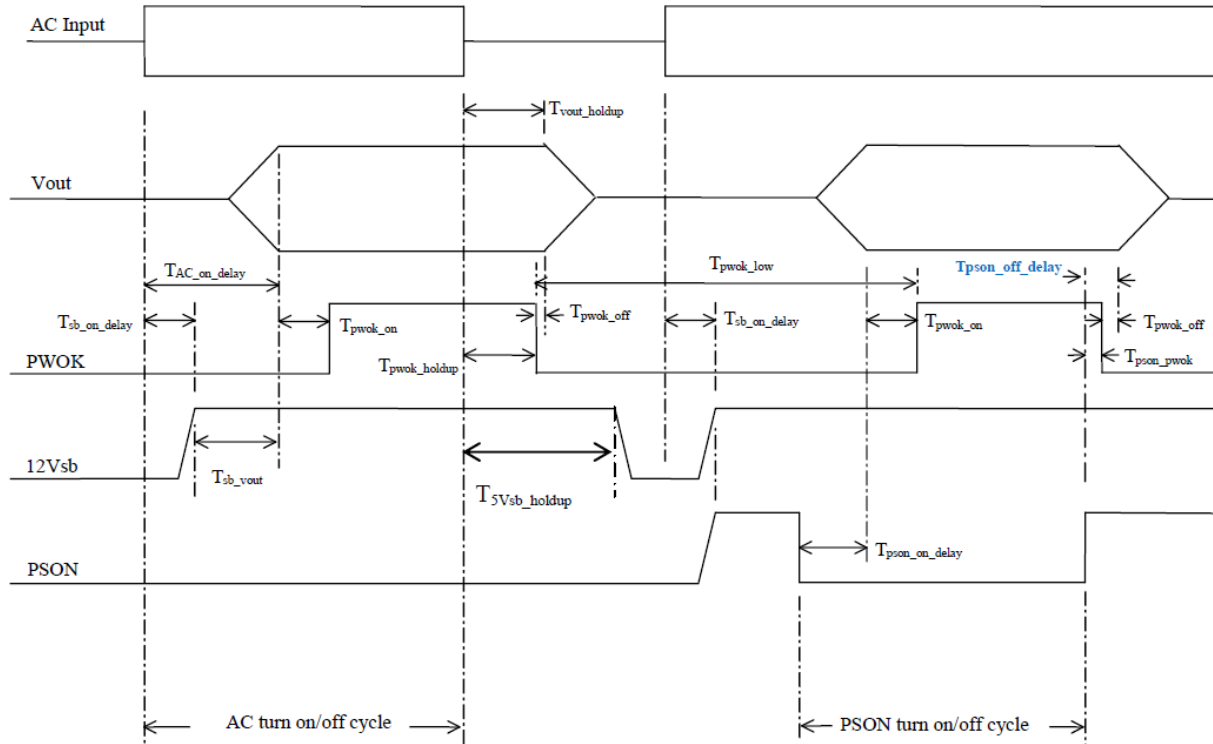

Figure 3 Turn On/Off Timing (Power Supply Signals)

7. Protection Circuits

Protection circuits inside the power supply only cause the power supply's main outputs to shut down. If the power supply latches off due to a protection circuit tripping, an AC cycle OFF for 15sec or a PSON# cycle HIGH for 1sec will reset the power supply.

7.1 Over Current Protection & Short Circuit Protection (OCP & SCP)

The power supply has over current protection (OCP) as defined in 23 below.

If the current limits are exceeded, the power supply will shut down and latch off. Once the over current condition is removed, the latch can be cleared by either an AC power interruption or by toggling the PSON input. The 12V standby output will automatically recover after the over current condition is removed.

Table 25 OCP Requirements

180-264Vac and HVDC		Current Threshold		Trip Timing		Comments
Spec	Description	MIN	MAX	MIN	MAX	
Fast OCP	Over current protection	282A	296A	100us		150us/289A typical
Fast OCW	Fast over current warning (SMBAlert#)	258A	282A	5us	20us	273A typical

Slow OCP	Slow over current protection (shutdown and latch after MIN/MAX timing)	212A	222A	10msec	50msec	20msec/217A typical
Slow OCW	Slow over current warning (SMBAlert#)	205A	215A	10msec	15msec	13msec/210A typical
20 sec OCP	Slow over current protection (shutdown, latch)	176A	184A	20sec		22sec/180A typical
OCPstby	Stby over current protection (shutdown, hiccup mode)	4.5A	5.5A	1ms		

90-140Vac		Current Threshold		Trip Timing		Comments
Spec	Description	MIN	MAX	MIN	MAX	
Fast OCP	Over current protection	186A	200A	100us		150us/193A typical
Fast OCW	Fast over current warning (SMBAlert#)	130A	146A	5us	20us	138A typical
Slow OCP	Slow over current protection (shutdown and latch after MIN/MAX timing)	114A	122A	10msec	50msec	20msec/118A typical
Slow OCW	Slow over current warning (SMBAlert#)	109A	117A	10msec	15msec	13msec/113A typical
20 sec OCP	Slow over current protection (shutdown, latch)	92A	100A	20sec		22sec/96A typical
OCPstby	Stby over current protection (shutdown, hiccup mode)	4.5A	5.5A	1ms		

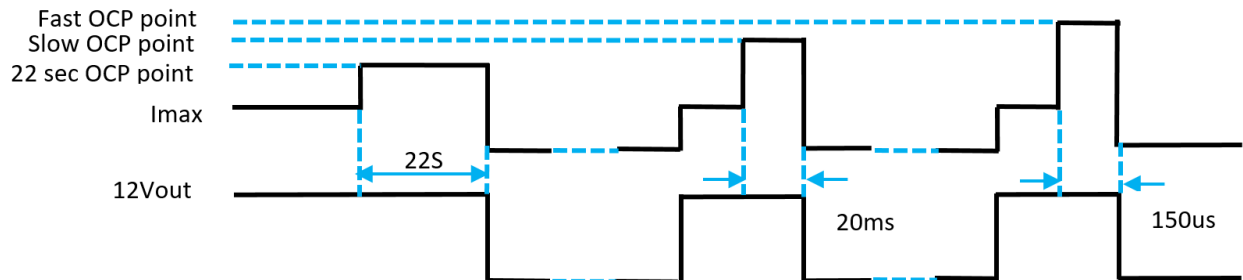

Figure 4 12V OCP latch off

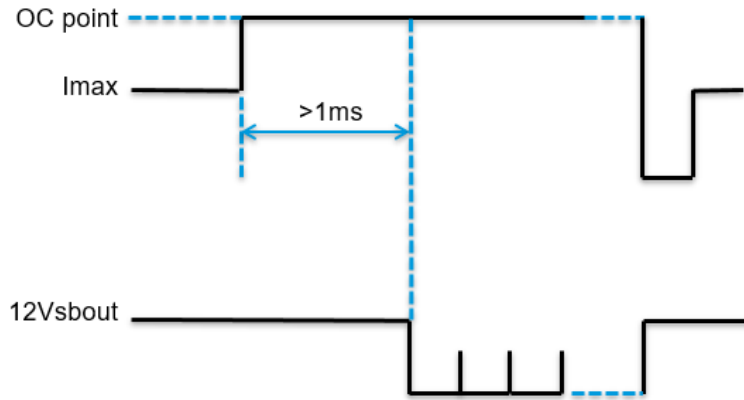

Figure 5 12Vsb OCP hiccup

7.2 Over Voltage Protection (OVP)

The power supply over voltage protection (100us delay time, typical) is locally sensed. The power supply will shut down and latch off after a 12V over voltage condition occurs. This latch can be cleared by either toggling the PSON# signal or by an AC power interruption.

The 12V standby output will automatically recover after the over voltage condition is removed.

Table 26 Over Voltage Protection (OVP) Limits

Output Voltage	MIN (V)	MAX (V)
+12V	13.3	14.5
+12VSB	13.3	14.5

Note: the OVP shutdown voltage is measured at the output of the card edge connector.

7.3 Under Voltage Protection (UVP)

Both main and standby outputs are monitored.

The main output will latch off if the voltage falls below 10V (typically in an overload or short circuit condition). The latch can be cleared by either toggling the PSON# signal or by an AC power interruption.

7.4 Over Temperature Protection (OTP)

The power supply is protected against over temperature conditions caused by a loss of fan cooling or an excessive ambient temperature. In an OTP condition, the power supply will shut down but will automatically return to normal operation once the power supply internal temperature drops to a safe operating condition.

8. Control and Indicator Functions

The following sections define the input and output signals from the power supply.

Signals that can be defined as low true use the following convention: Signal# = low true.

8.1 PSON# Input Signal

The PSON# signal is required to remotely turn on/off the power supply. PSON# is an active low signal that turns on the +12V power rail. When this signal is not pulled low by the system or left open, the 12V output will turn off (12V standby remains operational). This signal is pulled up to 3.3V by a 10K pull-up resistor.

Table 27 PSON# Signal Characteristic

Signal Type	Accepts an open collector/drain input from the system. Pull-up to 3.3V with a 10K resistor located in the power supply.	
PSON# = Low	ON	
PSON# = High or Open	OFF	
	MIN	MAX
Logic level low (power supply ON)	0V	1.0V
Logic level high (power supply OFF)	2.0V	3.46V
Source current, Vpson = low		4mA

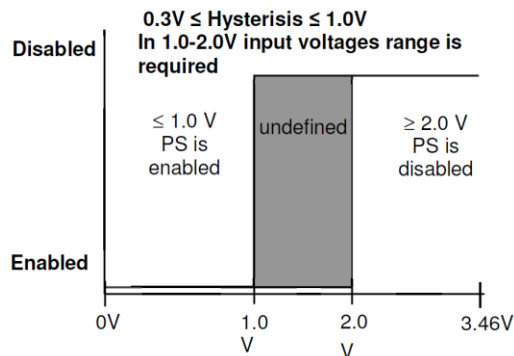

Figure 6 PSON# Required Signal Characteristic

8.2 PWOK (Power OK) Output Signal

PWOK is a power OK signal and is pulled HIGH to indicate that all outputs are within the regulation limits of the power supply. When any output voltage falls below the regulation limit or when AC power has been removed for a time sufficiently long so that the power supply operation is no longer guaranteed, the PWOK signal will be de-asserted to a LOW state. The start of the PWOK delay time is inhibited if any power supply output is in current limit.

Table 28 PWOK Signal Characteristics

Signal Type	Pull-up to 3.3V located in the power supply.	
PWOK = High	Power OK	
PWOK = Low	Power Not OK	
	MIN	MAX
Logic level low voltage, Isink=400uA	0V	0.4V
Logic level high voltage, Isource=200uA	2.4V	3.46V
Sink current, PWOK = low		400uA
Source current, PWOK = high		2mA

8.3 SMBAlert# Signal

The SMBAlert# signal is asserted due to Critical events or Warning events and indicates the power supply is experiencing a problem and the user should investigate.

By default, the SMBAlert# signal is asserted for the following cases:

1. STATUS_INPUT (UV Fault bit): input voltage drops to 0V for > 2ms.
2. STATUS_IOUT (Iout OC Warning bit): Output current exceeds the PSU capability, but PSU has not shutdown.
3. STATUS_TEMPERATURE (OT Warning): Thermal sensor for PS inlet temperature or on a hot spot inside the PSU has exceeded its warning temperature.

This signal is to be asserted in parallel with the LED turning solid Amber or blinking Amber.

Table 29 SMBAlert# Signal Characteristics

Signal Type (Active Low)	Open collector / drain output from power supply, pull up in system	
Alert# = High	OK	
Alert# = Low	Power Alert to system	
	MIN	MAX
Logic level low voltage, Isink=4 mA	0 V	0.4 V
Logic level high voltage, Isink=50 μA		3.46 V
Sink current, Alert# = low		4 mA
Sink current, Alert# = high		50 μA

8.4 PRESENT_L OUTPUT

The PRESENT_L pin is wired through a 100 Ohm resistor to internal GND within the power supply. This pin indicates there is a power supply present in the system slot. An external pull-up resistor must be added within the system application. Current into PRESENT_L should not exceed 5 mA to guarantee a low-level voltage if the power supply is seated.

8.5 12V Remote Sense

The 12V main output has sense lines implemented to compensate for voltage drop on connector and load wires in both positive and negative paths. The maximum allowed voltage drop is 200 mV on the positive rail and 50 mV on the return rail.

- a) When one or more remote sense lines are opened, the output voltage measured at the power supply output connector must be maintained within the regulation defined plus or minus an additional 250mV \pm 50mV.

If the +12V Remote Sense is shorted to Ground, the power supply will shut down and latch.

8.6 Hot Standby Operation

The hot-standby operation is an operating mode allowing for a further increase in efficiency at light load conditions in a redundant power supply system. Under specific conditions one of the power supplies is allowed to disable its 12V main output. This will reduce the power losses associated with this power supply and at the same time force the other power supply to operate in a load range with better efficiency.

To enable the hot-standby operation, the HOTSTANDBYEN_H (pin S5) and the ISHARE (pin S6) signals need to be interconnected between two or more power supplies. A power supply will only be allowed to enter the hot-standby mode when the HOTSTANDBYEN_H pin is high, the load current is low (see Figure 7) and a command to enter hot-standby mode is sent by the system controller. The system controller must ensure only one of the power supplies can enter hot-standby mode.

If a power supply is in a fault condition it will pull its HOTSTANDBYEN_H signal low which indicates it is not allowed to enter hot-standby mode or that it needs to return to normal operation should it already have been in hot-standby mode.

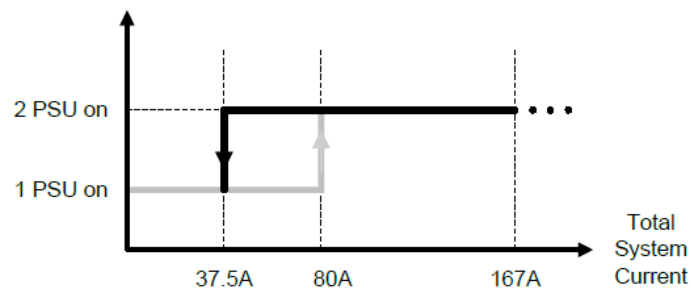

Figure 7 Hot-standby enable/disable typical current thresholds

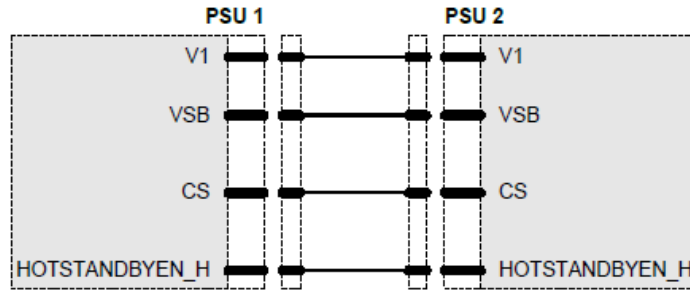

Figure 8 Recommended hot-standby configuration

9. Environmental Requirements

9.1 Temperature

Minimum operating ambient: -5°C

Maximum operating ambient: +55°C for full load (Normal airflow)

+45°C for full load (Reverse airflow)

Non-operating ambient: -40°C to +70°C (Maximum rate of change 20°C/hour)

Note:

1. Refer to figure 9 for normal airflow lout derating with temperature
2. Refer to figure 10 for reverse airflow lout derating with temperature

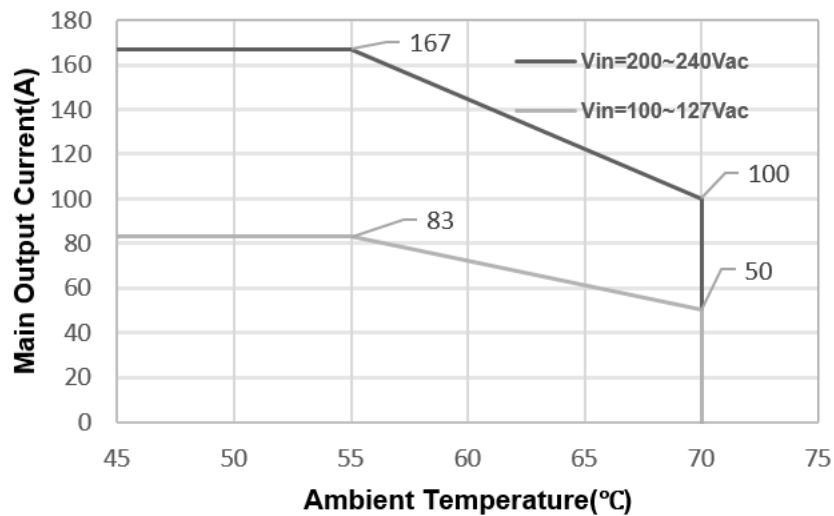

Figure 9 lout derating with temperature (Normal airflow)

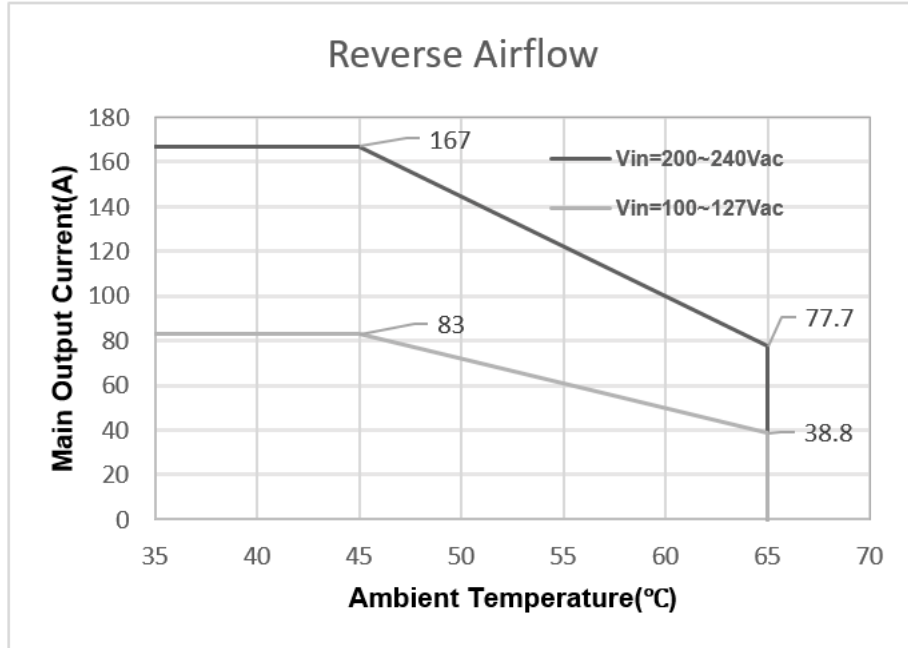

Figure 10 Iout derating with temperature (Reverse airflow)

9.2 Humidity

Operating: 95% relative humidity (non-condensing)

9.3 Altitude

Operating: Up to 5000m for safety creepage and clearance, meet Flex component derating up to 1000m and meet component rating up to 3050m at full load condition.

Non-operating: Up to 15200m

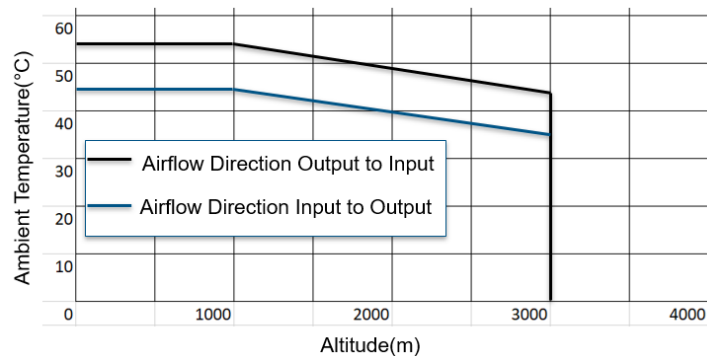

Figure 11 Temperature derating with altitude (100% load)

9.4 Mechanical Shock

PARAMETER	DESCRIPTION/CONDITION
Half-Sine Shock, Non-Operating	11ms, 30g peak, 10shocks/direction, total 6 directions
Half-Sine Shock, Operating	IPC-9592B 11ms, 30g, 3 shocks/axis, total 3axis

9.5 Vibration

PARAMETER	DESCRIPTION/CONDITION
Sinusoidal Vibration, Non-Operating	2Hz~9Hz, 3.5 mm; 9Hz~200Hz, 10m/s ² ; 200Hz~500Hz, 15m/s ² , 1oct/min, 5 sweep/axis
Sinusoidal Vibration, Operating	1g peak, sweep 5 to 500Hz, 1oct/min, 5 sweep/axis
Random Vibration, Operating	IPC-9592B 2.4Grms,10~500Hz,30min/axis
Random Vibration, Non-Operating	5Hz@0.01g ² /Hz to 20Hz@0.02g ² /Hz (slope up), 20Hz to 500Hz@0.02g ² /Hz (flat), 3.13Grms, 30min/axis, total 3 axis

9.6 Thermal Shock (Shipping)

Non-operating: -40°C to +70°C, 50 cycles, 30°C/min. ≥ transition time ≥ 15°C/min., duration of exposure to temperature extremes for each half cycle shall be 30 minutes.

10. Firmware Requirements

10.1 PMBus

Refer to PMBus Rev1.2 specification.

10.2 Power Reporting Accuracy

The power supply meets below power reporting accuracy requirements for any rated AC voltage.

Item	Description	Min	Nom	MAX	UNITS
Pin	Input power (50W < Pin < 500W)	-20		+20	W
	Input power (Pin > 500W)	-4%		+4%	
Vin	Input RMS voltage	-3		+3	Vrms
Iin	Input RMS current (Iin < 6.7A)	-0.2		+0.2	Arms
	Input RMS current (Iin > 6.7A)	-3%		+3%	
Pout	Output power (50W < Pout < 1000W)	-20		+20	W
	Output power (Pout > 1000W)	-2%		+2%	
12Vout	Output voltage	-0.1		+0.1	Vdc
Iout	Output current (5A < Iout < 50A)	-1		+1	A
	Output current (Iout > 50A)	-2%		+2%	
Tamb	Ambient temperature	- 4		+ 4	°C

10.3 Summary of SMBus/PMBus Commands

Code	Pages	Command	SMBus Transaction Type Status bit mapping
03h	NA	CLEAR_FAULTS	Send Byte w/PEC
05h	NA	PAGE_PLUS_WRITE (used with STATUS_WORD, STATUS_IOUT, STATUS_INPUT, STATUS_TEMPERATURE)	Block Write w/PEC Used with STATUS_INPUT, STATUS_TEMPERATURE, STATUS_IOUT
06h	NA	PAGE_PLUS_READ (used with STATUS_WORD, STATUS_IOUT, STATUS_INPUT, STATUS_TEMPERATURE)	Write Block Read Block Process Call w/PEC Used with STATUS_INPUT, STATUS_TEMPERATURE, STATUS_IOUT, STATUS_WORD
19h	NA	CAPABILITY	Read Byte w/PEC
1Ah	NA	QUERY (used with any command)	Block Write Block Read Process Call w/ PEC
1Bh	NA	SMBALERT_MASK (used with STATUS_INPUT, STATUS_TEMPERATURE, STATUS_IOUT)	Reading: Write Block Read Block Process Call w/PEC Writing: Write Word
20h		VOUT_MODE	Read/Write Byte w/PEC
3Ah	NA	FAN_CONFIG_1_2	
3Bh	NA	FAN_COMMAND_1	
79h	00h, 01h	STATUS_WORD	Read Word w/PEC
(Low) 6		OFF	PS off
4		IOUT_OC	Indeterminate (Use STATUS_IOUT)
2		TEMPERATURE	Indeterminate (Use STATUS_TEMPERATURE)
3		VIN_UV	Indeterminate (Use STATUS_INPUT)
1		CML	
(High) 7		VOUT	Failure
6		IOUT/POUT	Indeterminate (Use STATUS_IOUT)
5		INPUT	Indeterminate (Use STATUS_INPUT)
4		MFR_SPECIFIC (Incompatible Power Supply)	
3		POWER_GOOD#	
2		FANS	Indeterminate (Use STATUS_FANS)
7Ah	NA	STATUS_VOUT	Read Byte w/PEC
7		VOUT_OV_FAULT	Failure
4		VOUT_UV_FAULT	Predictive failure
7Bh	00h, 01h	STATUS_IOUT	Read Byte w/PEC
7		Iout OC fault	Failure
5		No support	No support
1		Pout OP fault	Failure
0		No support	No support
7Ch	00h, 01h	STATUS_INPUT	Read Byte w/PEC
5		No support	No support
4		Vin UV fault	AC Loss

3		Unit off for insufficient input	AC Loss
1		No support	No support
0		No support	No support
7Dh	00h, 01h	STATUS_TEMPERATURE	Read Byte w/PEC
7		OT fault	Fault
6		OT warning	Predictive fault
81h	00h	STATUS_FANS_1_2	Read Byte w/PEC
7		Fan 1 fault	Failure
6		Fan 2 fault	Failure
5		Fan 1 warning	Predictive failure
4		Fan 2 warning	Predicative failure
88h	NA	READ_VIN	Read Word w/PEC
89h	NA	READ_IIN	Read Word w/PEC
8Bh	NA	READ_VOUT	Read Word w/PEC
8Ch	NA	READ_IOUT	Read Word w/PEC
8Dh	NA	READ_TEMPERATURE_1 (Ambient)	Read Word w/PEC
8Eh	NA	READ_TEMPERATURE_2 (Hot Spot)	Read Word w/PEC
90h	NA	READ_FAN_SPEED_1	Read Word w/PEC
96h	NA	READ_POUT	Read Word w/PEC
97h	NA	READ_PIN	Read Word w/PEC
98h	NA	PMBUS_REVISION	Read Byte w/PEC
9Ah	NA	MFR_MODEL	Block Read
9Bh	NA	MFR_REVISION	Block Read
9Fh	NA	APP_PROFILE_SUPPORT	Read Byte w/PEC
A6h	NA	MFR_IOUT_MAX	Read Word w/PEC
A7h	NA	MFR_POUT_MAX	Read Word w/PEC
C0h	NA	MFR_MAX_TEMP_1 (Ambient)	Read Word w/PEC
C1h	NA	MFR_MAX_TEMP_2 (hot Spot)	Read Word w/PEC
D0h	NA	MFR_COLD_REDUNDANCY_ CONFIG	Read/Write Byte w/PEC
D1h – D3h		reserved	
D4h	NA	MFR_HW_COMPATIBILITY	Read Word w/PEC
D5h	NA	MFR_FWUPLOAD_CAPABILI TY	Read Byte w/PEC
D6h	NA	MFR_FWUPLOAD_MODE	Read/Write Byte w/PEC
D7h	NA	MFR_FWUPLOAD	Block Write w/ PEC (size = block size from image header)
D8h	NA	MFR_FWUPLOAD_STATUS	Read Word w/PEC
D9h	NA	MFR_FW_REVISION	Block Read w/PEC (3 bytes)
DEh	00h, 01h,02h	Hot-Standby	Read/Write Word w/PEC
0		0=disable(default), 1=enable	HS select RW
1		0=low, 1=high	HS enable line RO

2		0=not active, 1=active	HS status RO
3-F			Reserved RO
E5h	NA	MFR_BLACKBOX	Block Read w/ PEC (237 bytes)
E6h	NA	MFR_REAL_TIME_BLACK_BOX	Block Write/Read w/ PEC (4 bytes)
E7h	NA	MFR_SYSTEM_BLACK_BOX	Block Write/Read w/ PEC (40 bytes)

10.4 Supports Operation With and Without PEC

Example:

Read word without PEC

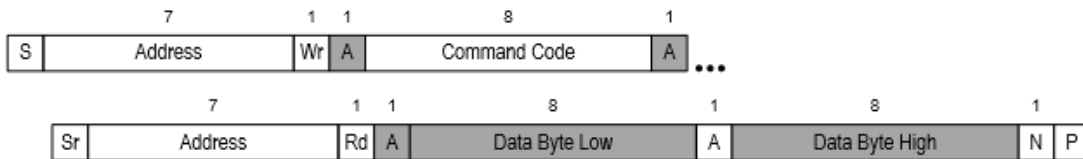

Read word with PEC

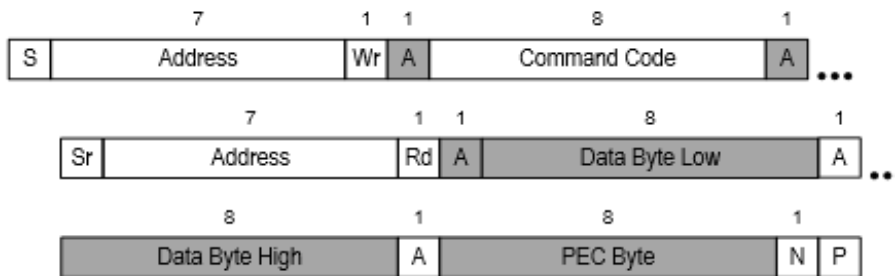

Write word without PEC

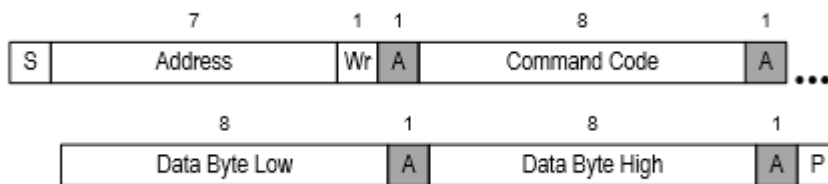

Write word with PEC

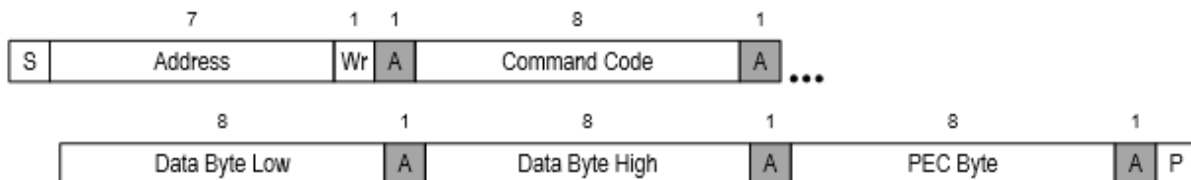

11. Reliability

11.1 Component De-rating

The components in this product are required to comply with Flex internal design and qualification requirements. Any exceptions are subject to final approval by Flex Design Engineering.

11.2 Life Requirement

The power supply supports a **5-year** calculated life under the following conditions.

Normal airflow testing condition:

- 100VAC or 240VAC input
- 55°C inlet temperature
- 20% of the time at 20% load; 80% of the time at 80% load

Reverse airflow testing condition:

- 100VAC or 240VAC input
- 45°C inlet temperature
- 20% of the time at 20% load; 80% of the time at 80% load

11.3 Mean Time Between Failures (MTBF)

Normal airflow:

The power supply shall have a minimum MTBF at continuous operation of 250,000 hours at the condition of 230VAC, 80% load and 50°C, as calculated by Telcordia SR-332 Issues 2.

Reverse airflow:

The power supply shall have a minimum MTBF at continuous operation of 250,000 hours at the condition of 230VAC, 80% load and 40°C, as calculated by Telcordia SR-332 Issues 2.

12. Ecology Requirements

- Directive of the European Parliament and of the Council on the Restriction of the Use of Certain Hazardous Substances in Electrical and Electronic Equipment, 2011/65/EU, June 2011 (RoHS Directive) and 2015/863/EU, June 2015 (addition of four phthalates)
- Regulation of the European Parliament and of the Council on the Registration, Evaluation, Authorization and Restriction of Chemicals, 1907/2006/EC, December 2006 (REACH)

13. Regulatory Requirements

Intended Application – This product was evaluated as Information Technology Equipment (ITE) which may be installed in offices, schools, computer rooms, and similar commercial type locations. The suitability of this product for other product categories and environments other than an ITE applications may require further evaluation.

13.1 Product Safety Compliance

UL&cUL: UL60950-1/CSA 60950-1 / UL62368-1 (USA / Canada)

CB: IEC60950-1 / IEC62368-1/EN60950-1 / EN62368-1 (EN60950-1/EN62368-1 covered by CB)

CE - Low Voltage Directive 2014/35/EU (Europe)

CQC: GB 4943.1

EAC(CU): IEC 60950-1

BSMI: CNS13438, CNS14336-1

13.2 Product EMC Compliance – Class A Compliance

Note: The product complies with Class A emission requirements (designed with 6dB margin) as the end system that it is configured into is intended for a commercial environment and marketplace.

FCC /ICES-003 part 15 - Emissions (USA/Canada) Verification

CISPR 32 – Emissions (International)

EN55032 - Emissions (Europe)

EN55024 - Immunity (Europe)

- EN61000-4-2 Electrostatic Discharge, 8kV contact discharge voltage and 15kV air discharge voltage
- EN61000-4-3 Radiated RFI Immunity
- EN61000-4-4 Electrical Fast Transients, common mode 2.0 kV and differential mode 1.0 kV
- EN61000-4-5 Electrical Surge, common mode 2.0 kV and differential mode 1.0 kV
- EN61000-4-6 RF Conducted Immunity, 10Vrms
- EN61000-4-8 Power Frequency Magnetic Fields
- EN61000-4-11 Voltage Dips and Interruptions (refer to table 9.2)

EN61000-3-2 - Harmonics (Europe)

EN61000-3-3 - Voltage Flicker (Europe)

AS/NZS CISPR 32 (Australia / New Zealand)

GB 17625.1, GB/T 9254

13.3 NEBS Compliance

The product is designed to meet below NEBS requirements

GR-63-CORE (Issue 5, Short term operating temperature)

PSU can operate at rated temperature+10°C max with output power derating (refer to PSU Spec figure 9 and figure 10 in spec), it will help system pass GR-63-CORE short term high operating temperature requirement

GR-1089-CORE (Issue 7, EMC)

- ESD, meet GR-1089-CORE, normal operation table 2-1, contact ESD 8KV and air ESD 15KV for AC input (type 7 port type)
- EFT, meet GR-1089-CORE, 2KV EFT on AC input (type 7 port type)
- Radiated emission, meet GR-1089-CORE radiated emission requirement for class A table 3-1
- Conducted emission, meet GR-1089-CORE conducted emission requirement for class A table 3-3 for AC port
- Radiated immunity, meet GR-1089-CORE radiated immunity requirement table 3-7 for AC port
- Conducted immunity, meet GR-1089-CORE conducted immunity 8.5V/M from 10KHz to 10GHz
- Surge, meet GR-1089-CORE table4-2 number 20 on AC input (type 7 port type), 2KV surge with 1.2/50us voltage and 2 ohms internal impedance without external SPD