

OPEN

Compute Project

1200W DC Power Supply

Revision 01

1. License (**OCP CLA Option**)

Contributions to this Specification are made under the terms and conditions set forth in Open Compute Project Contribution License Agreement (“OCP CLA”) (“Contribution License”) by:

Flextronics Power Systems

Usage of this Specification is governed by the terms and conditions set forth in **Open Compute Project Hardware License – Permissive (“OCPHL Permissive”), (“Specification License”)**.

Note: The following clarifications, which distinguish technology licensed in the Contribution License and/or Specification License from those technologies merely referenced (but not licensed), were accepted by the Incubation Committee of the OCP:

NOTWITHSTANDING THE FOREGOING LICENSES, THIS SPECIFICATION IS PROVIDED BY OCP "AS IS" AND OCP EXPRESSLY DISCLAIMS ANY WARRANTIES (EXPRESS, IMPLIED, OR OTHERWISE), INCLUDING IMPLIED WARRANTIES OF MERCHANTABILITY, NON-INFRINGEMENT, FITNESS FOR A PARTICULAR PURPOSE, OR TITLE, RELATED TO THE SPECIFICATION. NOTICE IS HEREBY GIVEN, THAT OTHER RIGHTS NOT GRANTED AS SET FORTH ABOVE, INCLUDING WITHOUT LIMITATION, RIGHTS OF THIRD PARTIES WHO DID NOT EXECUTE THE ABOVE LICENSES, MAY BE IMPLICATED BY THE IMPLEMENTATION OF OR COMPLIANCE WITH THIS SPECIFICATION. OCP IS NOT RESPONSIBLE FOR IDENTIFYING RIGHTS FOR WHICH A LICENSE MAY BE REQUIRED IN ORDER TO IMPLEMENT THIS SPECIFICATION. THE ENTIRE RISK AS TO IMPLEMENTING OR OTHERWISE USING THE SPECIFICATION IS ASSUMED BY YOU. IN NO EVENT WILL OCP BE LIABLE TO YOU FOR ANY MONETARY DAMAGES WITH RESPECT TO ANY CLAIMS RELATED TO, OR ARISING OUT OF YOUR USE OF THIS SPECIFICATION, INCLUDING BUT NOT LIMITED TO ANY LIABILITY FOR LOST PROFITS OR ANY CONSEQUENTIAL, INCIDENTAL, INDIRECT, SPECIAL OR PUNITIVE DAMAGES OF ANY CHARACTER FROM ANY CAUSES OF ACTION OF ANY KIND WITH RESPECT TO THIS SPECIFICATION, WHETHER BASED ON BREACH OF CONTRACT, TORT (INCLUDING NEGLIGENCE), OR OTHERWISE, AND EVEN IF OCP HAS BEEN ADVISED OF THE POSSIBILITY OF SUCH DAMAGES.

Table of Contents

1.	LICENSE (OCP CLA OPTION).....	2
	TABLE OF CONTENTS.....	3
2.	SCOPE & OVERVIEW	6
3.	MECHANICAL OVERVIEW	6
3.1	DC Output Connector	7
3.2	Handle Retention	8
3.3	LED Marking and Identification	8
3.4	Acoustic Requirements.....	9
3.5	Fan and Fan Speed Control Requirements.....	9
3.6	Thermal Sensors and OTP.....	10
4.	DC INPUT REQUIREMENTS	11
4.1	DC Inlet Connector	11
4.2	DC Input Voltage Specification	11
4.3	DC Line Isolation Requirements.....	11
4.4	DC Line Holdup.....	11
4.5	DC Line Fuse	12
4.6	DC Inrush.....	12
5.	EFFICIENCY	12
6.	DC OUTPUT SPECIFICATION	13
6.1	Output Power / Currents.....	13
6.2	Voltage Regulation	13
6.3	Dynamic Loading	14

6.4	Capacitive Loading	14
6.5	Hot Swap Requirements.....	15
6.6	Load Sharing.....	15
6.7	Ripple / Noise.....	15
6.8	Timing Requirements	16
7.	PROTECTION CIRCUITS.....	18
7.1	Over Current Protection & SCP (OCP & SCP)	18
7.2	Over Voltage Protection (OVP).....	19
7.3	Under Voltage Protection (UVP).....	19
7.4	Over Temperature Protection (OTP).....	19
8.	CONTROL AND INDICATOR FUNCTIONS.....	20
8.1	PSON# Input Signal.....	20
8.2	PWOK (Power OK) Output Signal.....	20
8.3	SMBAlert# Signal	21
8.4	PRESENT_L OUTPUT	21
8.5	12V Remote Sense.....	22
8.6	Hot Standby In/out.....	22
9.	ENVIRONMENTAL REQUIREMENTS	23
9.1	Temperature	23
9.2	Humidity	24
9.3	Altitude	24
9.4	Mechanical Shock.....	24
9.5	Vibration	24
10.	FIRMWARE REQUIREMENTS	25

10.1	PMBus	25
10.2	Power Measure Preciseness	25
10.3	Summary of SMBus/PMBus Commands	25
10.4	Support the Both Operation With and Without PEC	27
11.	RELIABILITY	28
11.1	Component De-rating	28
11.2	Life Requirement	28
11.3	Mean Time Between Failures (MTBF)	29
12.	ECOLOGY REQUIREMENTS	29
13.	REGULATORY REQUIREMENTS	29
13.1	Product Safety Compliance	29
13.2	Product EMC Compliance – Class A Compliance	30
13.3	NEBS Compliance	30

2. Scope & Overview

This specification defines requirements for Open Compute Project Power Supply for DC1200W supporting server systems. This is a 1200W power supply with 12V main output and 12V standby output.

FPS-S-1200DDL00-101 is a normal airflow (from output connector to DC input connector) 1200 Watt DC to DC power supply

FPS-S-1200DDL00-201 is a reverse airflow (from DC input connector to output connector) 1200 Watt DC to DC power supply

3. Mechanical Overview

The physical size of the power supply enclosure is defined below. The power supply contains a single rotor 40mm fan. The power supply has a card edge output connector that interfaces with connector in the system. The DC plugs directly into the external face of the power supply. Refer to the below attached mechanical drawing below.

Dimensions	40mm x 73.5mm x 265mm (H x W x D)
Output connector	Card edge compatible with FCI (10130248-005LF) or equivalent

Detailed mechanical drawing as follows

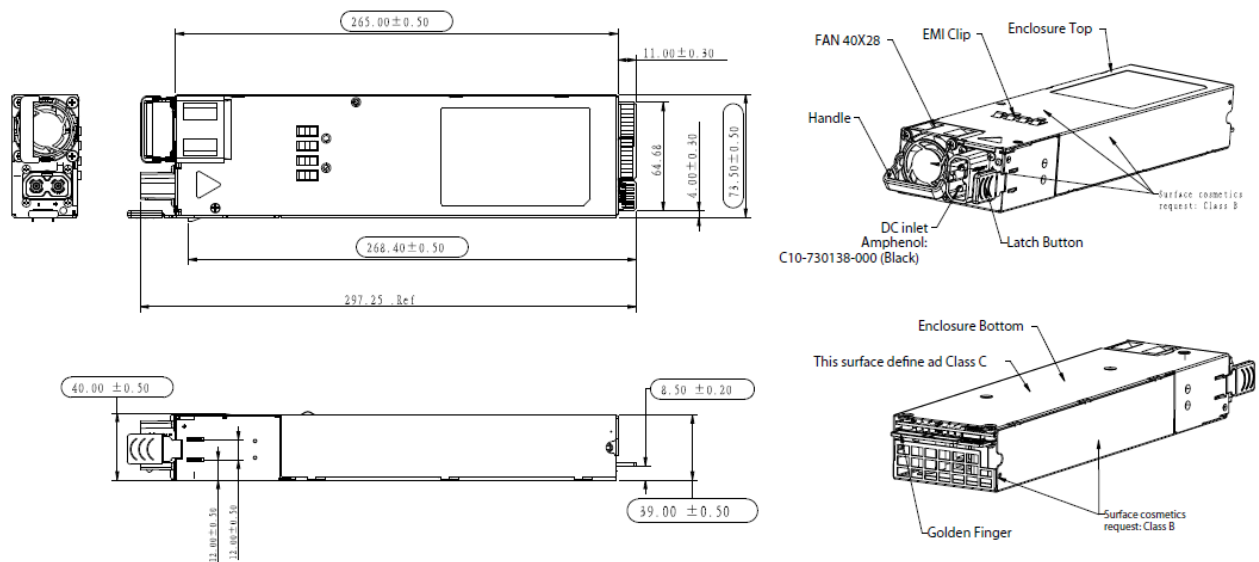

Figure 1 Power Supply Outline Drawing

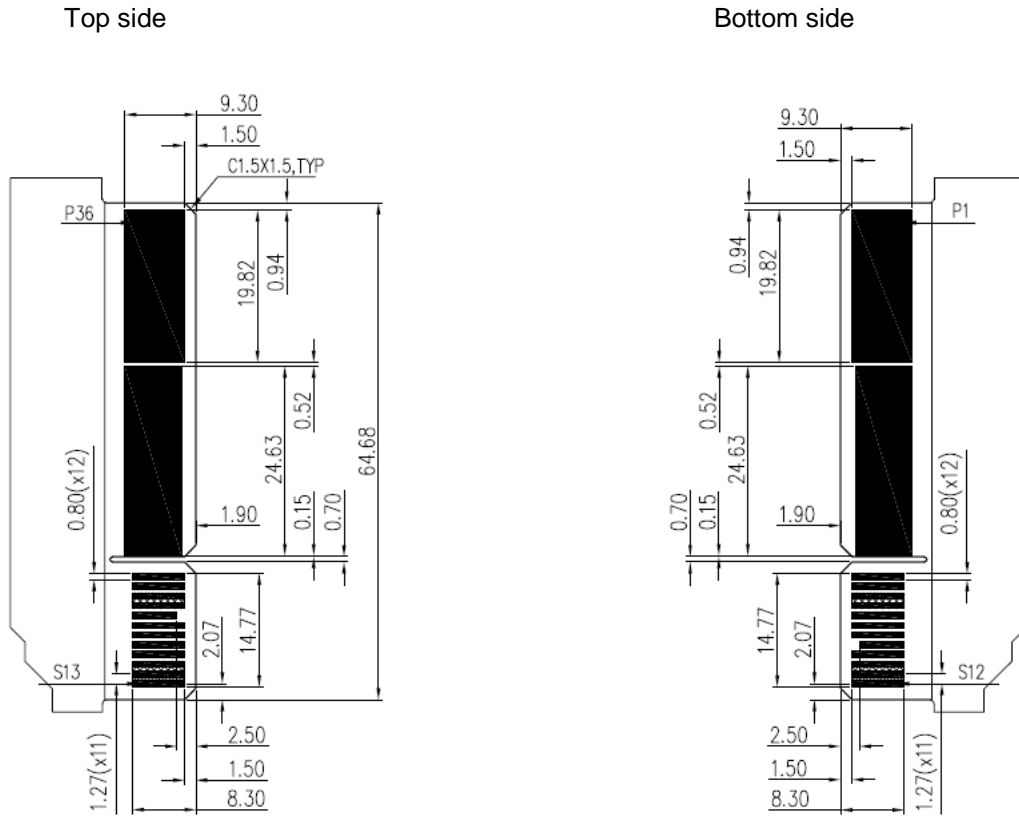
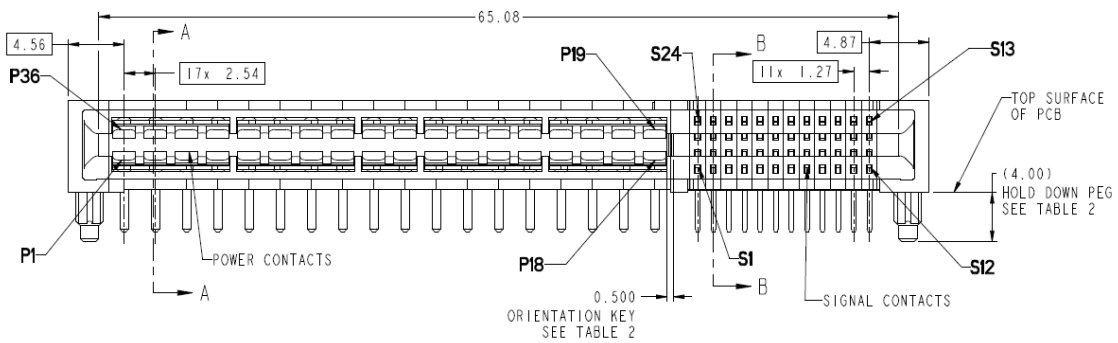

Figure 2 Output card edge gold finger

3.1 DC Output Connector

The power supply card edge pinout is defined in the table below. This card edge is compatible with FCI Connector(10130248-005LF) or equivalent.



Pin	Name	Pin	Name
P1	GND	P36	GND
P2	GND	P35	GND
P3	GND	P34	GND
P4	GND	P33	GND
P5	GND	P32	GND

P6	GND	P31	GND
P7	GND	P30	GND
P8	GND	P29	GND
P9	GND	P28	+12V
P10	GND	P27	+12V
P11	+12V	P26	+12V
P12	+12V	P25	+12V
P13	+12V	P24	+12V
P14	+12V	P23	+12V
P15	+12V	P22	+12V
P16	+12V	P21	+12V
P17	+12V	P20	+12V
P18	+12V	P19	+12V
S1	A0 (SMBus address)	S24	SDA
S2	A1 (SMBus address)	S23	SCL
S3	12V stby	S22	12V stby
S4	12V stby	S21	12V stby
S5	HOTSTANDBYEN_H	S20	PSON#
S6	12V load share bus	S19	SMBAlert#
S7	Reserved	S18	Return Sense
S8	PRESENT_L	S17	+12V remote Sense
S9	A2 (SMBus address)	S16	PWOK
S10	GND	S15	GND
S11	GND	S14	GND
S12	GND	S13	GND

3.2 Handle Retention

The power supply has a handle to assist extraction and can be inserted and extracted without the assistance of tools. The power supply also has a latch which retains the power supply into the system and prevents the power supply from being inserted or extracted from the system. The handle protects the operator from any burn hazard.

3.3 LED Marking and Identification

The power supply is designed with a bi-color LED; Amber & Green.

Table 1 LED State

Power Supply Condition	LED State
Output ON and OK	GREEN
No DC power to all power supplies	OFF
PSU in standby state DC present / Only 12VSB on	1Hz Blinking GREEN
Power supply in Hot-Standby state	1Hz Blinking GREEN
DC cord unplugged, or DC power lost; with a second power supply in parallel with DC input power.	AMBER
Power supply critical event causing a shutdown; failure, over current, short circuit, over voltage, fan failure, over temperature	AMBER

Power supply warning events where the power supply continues to operate; high temp, high power, high current, slow fan.	1Hz Blinking Amber
Power supply firmware updating	2Hz Blinking GREEN

Design note: LEDs is controlled by firmware to allow for a change to the blink rates and color to the above states by an update to the PSU secondary side firmware. This allows the PSU to be reprogrammed to match different customers' LED state requirements.

3.4 Acoustic Requirements

The power supply incorporates a variable speed fan. The declared sound power levels of the power supply meet the requirements shown in the table below. Sound power is measured according to ECMA 74 (www.ecma-international.org) and ISO7779, reported according to ISO 9296.

The ambient temperature listed in Table 2 is the inlet temperature to the power supply.

Table 2 Sound Power Requirement

Inlet Temperature Condition	% of Maximum Loading Condition	Declared Sound Power
25C	50%	65 dBA

3.5 Fan and Fan Speed Control Requirements

The power supply incorporates a single rotor, 40mm fan for cooling the power supply.

When installed in the system, the airflow direction is defined below:

Normal airflow: From output connector to the DC inlet connector. The latch button color is RED, and handle color is BLACK.

Reverse airflow: From the DC inlet connector to output connector. The latch button color is BLACK, and handle color is BLACK.

The Fan speed control has a closed loop algorithm based on both the loading condition and the ambient temperature (Inlet temperature), see below Table . Ensuring the PSU fan will always ramp to maximum speed (30000 RPM typical) under any condition to protect the power supply from overheating.

Table 3 Fan Typical RPM control (normal airflow)

RPM Loading	Outlet Input Air Ambient Temperature						
	25	30	35	40	45	50	≥55
0%	5000	5000	5000	5000	14000	18000	26000
10%	5700	5700	5700	5700	14000	18000	26000
20%	6400	6400	6400	6400	14000	18000	26000
30%	7100	7100	7100	10000	14000	18000	26000
40%	7800	7800	7800	12000	22000	26000	Max speed

50%	8500	8500	8500	14000	22000	26000	Max speed
60%	14000	14000	14000	18000	26000	26000	Max speed
70%	18000	18000	18000	18000	26000	26000	Max speed
80%	22000	22000	26000	26000	Max speed	Max speed	Max speed
90%	26000	26000	Max speed	Max speed	Max speed	Max speed	Max speed
100%	26000	26000	Max speed	Max speed	Max speed	Max speed	Max speed

Table 4 Fan Typical RPM control (reverse airflow)

RPM	DC Inlet Side Input Air Ambient Temperature						
	25	30	35	40	45	50	≥55
0%	5000	5000	14000	18000	Max speed	Max speed	Max speed
10%	5700	5700	14000	18000	Max speed	Max speed	Max speed
20%	6400	6400	14000	18000	Max speed	Max speed	Max speed
30%	7100	10000	14000	18000	Max speed	Max speed	Max speed
40%	7800	12000	22000	26000	Max speed	Max speed	Max speed
50%	8500	14000	22000	26000	Max speed	Max speed	Max speed
60%	14000	18000	26000	26000	Max speed	Max speed	Max speed
70%	18000	18000	26000	26000	Max speed	Max speed	Max speed
80%	26000	26000	Max speed	Max speed	Max speed	Max speed	Max speed
90%	Max speed	Max speed	Max speed	Max speed	Max speed	Max speed	Max speed
100%	Max speed	Max speed	Max speed	Max speed	Max speed	Max speed	Max speed

Note: When load changes, transition to the steady state fan speed shall take place within 60 seconds.

3.6 Thermal Sensors and OTP

The PSU has thermal sensors to measure inlet/outlet temperature and hot spot component temperatures. These are used for asserting the over temperature warning condition (OTW), over temperature protection/shutdown (OTP), reporting temperatures via PMBus, and for controlling the fan speed.

Accuracy of the ambient thermal sensors is +/-4°C.

Inlet ambient temperature sensors OTW and OTP levels are defined in the below **Table** .

Below both the hotspot thermal sensor(s) and the ambient inlet thermal sensor shall have both OTW level and OTP level associated with them.

- *OTW: Over temperature warning level associated with all thermal sensors. This asserts the SMBAlert# signal and does not shut down the PSU. This also asserts the associated PMBus STATUS warning bits. This support the CLST (Closed Loop System Throttling) feature.*
- *OTP: Over temperature protection level associated with all thermal sensors. This shuts down the PSU to protect any components from exceeding their maximum temperature. This also asserts the associate PMBus STATUS bits.*

Table 5 Ambient Sensor Trip Typical Levels

	Reverse airflow	Normal airflow
Over temp warning, Amb Temp (OTW)	70°C	70°C
Over temp shutdown, Amb Temp (OTP)	74°C	74°C

Note: Internal fan speed control algorithm ramps up the fan speed to the maximum prior to the SMBAlert insertion.

4. DC Input Requirements

4.1 DC Inlet Connector

The DC receptacle is **Amphenol #C10-730138-000,3.6mm** power inlet.

4.2 DC Input Voltage Specification

The power supply operates within all specified limits over the following input voltage range. Application of an input voltage -32VDC typical the Stand-by output available and DSP working normal, support 3.5A max peak load (less than 500msec) and 2A max continue load if input voltage is less than -40V.

Table 6 DC Input Voltage Range

PARAMETER	MIN	NOM	MAX	Start Up	Power Off
Voltage	-40VDC	-53VDC	-72VDC	-41.5+/-0.5VDC	-38.75+/-0.75VDC

4.3 DC Line Isolation Requirements

The power supply meets section12 mentioned safety agency requirements for dielectric strength.

Table 7 Insulation and Electric Strength Testing

Parameters	DESCRIPTION / CONDITION	NOTES
Grade of Insulation	Input to chassis (PE)	Basic
	Input to output	Basic
	Output to chassis (PE)	None (Output connected to chassis)
Electrical Strength Test	Input to chassis (PE)	1500VDC
	Input to output	1500VDC

4.4 DC Line Holdup

The power supply meets the DC holdup requirement at -48V input voltages (10sec interval between each sagging). A dropout of the DC line for any duration will not cause damage to the power supply.

Table 8 DC Holdup

Loading during DC holdup	12V Main Output Holdup time
70% of max load	1.0ms

Note: This must be tested with a bulk capacitor having the minimum capacitance tolerance.

4.5 DC Line Fuse

An 60A input fuse in the negative voltage path inside the power supply protect against severe defects. The fuse is not accessible from the outside and are therefore not serviceable parts.

4.6 DC Inrush

When input power is applied to the power supply and any initial current surge or spike of 5ms shall not exceed 55A peak at cold start.

The power supply must meet the inrush requirements for any normal DC voltage, Inrush current caused by X cap or Y cap is not considered.

5. Efficiency

The power supply shall test for efficiency to meet below table 10.

The testing procedure and testing method are as follows:

- Efficiency shall be measured at -53Vdc.
- Both the +12V and +12Vsb outputs should be at the same percentage of their max load.
- The efficiency test does not include the losses of the PSU fan.
- The ambient temperature will be between 18°C and 28°C.

The Power Supply will dwell at each specified set point for 15 minutes before efficiency is measured.

Table 9 Efficiency Requirement

Loading	100% of maximum	50% of maximum	20% of maximum
Platinum efficiency	≥ 91%	≥ 94%	≥ 90%

6. DC Output Specification

6.1 Output Power / Currents

The following tables defines the minimum power and current ratings. The power supply must meet both static and dynamic voltage regulation requirements for all conditions.

Table 10 Load Requirements

Output	Input Voltage (VDC)	Power 1 Max. (W)	Min. (A)	Max. Continuous (A)	Peak Current 20sec duration 2 (A)	Pmax.app Peak 10msec duration 3(A)	Pmax Peak 100µsec duration 4(A)
12V main	-40~-72	1200	0.1	100	110	125	150
12Vstby	-40~-72	42	0.05	3.5	4		

Notes:

1. Maximum continuous output power for all outputs must not exceed 1200W.
2. The load can apply for 20 seconds at 110A level and 20 seconds at 100A level with -53Vdc input, this cycle can be repeated to maintain the average power 105% of rated power level at normal airflow 55°C and reverse airflow 45°C.
3. The load can apply for 10msec at 125A level and 40msec at 100A level with -53Vdc input, this cycle can be repeated to maintain the average power 105% of rated power level at normal airflow 55°C and reverse airflow 45°C. Applying a Pmax.app peak load must not trip the SMBAlert# signal. The PSU support this peak load for 5msec after SMBAlert# asserts.
4. The load can apply for 100µsec at 150A level and a duration at 100A level with -53Vdc input, this cycle can be repeated to maintain the average power 105% of rated power level at normal airflow 55°C and reverse airflow 45°C. Pmax peak can support based on PMAX Protection requirements that included added system 12V capacitors. Apply loading greater than Pmax.app load may trip the SMBAlert# signal for quickly throttling the processor and memory load.

Table 11 PMAX Protection Testing Conditions

Pmax Peak Load	Peak current	System capacitance	SMBAlert# timing	Peak load duration	Voltage undershoot
1800W	150A	6 x 1,500µF	< 20µsec	100µsec	-2% (11.172V)

6.2 Voltage Regulation

The power supply output voltages must stay within the following voltage limits when operating at steady state, load transition state and dynamic loading conditions. The test capacitive load (table 16) for each PSU is required to meet voltage regulation.

Table 12 Static Voltage Regulation Set Point

Output	Load	MIN	NOM	MAX	UNITS
+12V	50% of max load	+11.95	+12.00	+12.05	Vrms
+12VSB	1.75A	+11.95	+12.00	+12.05	Vrms

Table 13 Voltage Regulation Limits

PARAMETER	MIN	NOM	MAX	UNITS
+12V	11.40	12.00	12.60	V
+12VSB	11.40	12.00	12.60	V

Table 14 Load Transition Voltage Regulation Limits

Output	Min load	Δ Step Load Size	Load Slew Rate	Min Cap	dVout max
+12V	10% of max load	40% of max load	0.5A/ μ s	2,200 μ F	0.6V
+12VSB	5% of max load	1A	0.5A/ μ s	0 μ F	1.2 V

Table 15 Load Regulation Limits

PARAMETER	MIN	NOM	MAX	UNITS
+12V	-83	-110	-138	mV
+12VSB	-144	-240	-330	mV

6.3 Dynamic Loading

The output voltages shall remain within limits specified for the step loading and capacitive loading specified in the table below. The load transient repetition rate shall be tested between 50Hz and 5kHz at duty cycles ranging from 10%-90%. The load transient repetition rate is only a test specification. The Δ step load may occur anywhere within the Min load to the Max load conditions. The test capacitive load (table 16) for each PSU on 12V output is required to hold regulation during Hot standby mode PSU failures and PSU hot swapping

Table 16 Dynamic Load Requirements

Output	Min load	Δ Step Load Size	Load Slew Rate	Test capacitive Load
+12V	10A	40% of max load	0.5 A/ μ sec	2,200 μ F
+12VSB	0.1A	1.0A	0.5 A/ μ sec	100 μ F

6.4 Capacitive Loading

The power supply shall be stable and meet all requirements with the following capacitive loading ranges.

Table 17 Capacitive Loading Conditions

Output	MIN	MAX	Units
+12VSB	0	3,100	μ F
+12V	0	30,000	μ F

6.5 Hot Swap Requirements

Hot swapping a power supply is the process of inserting and extracting a power supply from an operating power system. During this process the output voltages shall remain within the limits with the capacitive load specified. The hot swap test may be conducted when the system is operating under static, dynamic, and zero loading conditions.

6.6 Load Sharing

The +12V output is designed with active load sharing. The 12VSB output uses the droop method. Refer to table 15 the droop voltage for load sharing and refer to table 12 for voltage set point. The 12Vsb output has 240mV typical droop voltage from no load to full load.

Table 18 +12V output sharing accuracy

+12V loading	Deviation from I_{tot} / N
0% - 100%	+/-2.5A

Table 19 +12Vsb output sharing accuracy

+12Vsb loading	Deviation from I_{tot} / N
100%	+/-1A

Note: I_{tot} is the total output current, N is the PSU quantity.

12V Load share bus voltage must meet below table.

+12V loading	Min.	Typ.	Max.	Unit
0%	-0.3	0	0.3	V
10%	0.6	0.8	1.0	V
20%	1.4	1.6	1.8	V
50%	3.8	4.0	4.2	V
100%	7.8	8.0	8.2	V
+12V peak(110A)	8.84	9.14	9.44	V

The 100% load means 100A output.

6.7 Ripple / Noise

The maximum output ripple/noise of the power supply is defined in below. This is measured over a bandwidth of 10Hz to 20MHz at the power supply output connectors. A 10 μ F ceramic capacitor and a 0.1 μ F ceramic capacitor in parallel with 2200 μ F conductive polymer electrolytic cap are placed at the point of 12V output. A 10 μ F and a 0.1 μ F ceramic capacitor in parallel with 1000 μ F are placed at the point of 12VSB output.

Table 20 Ripples and Noise

+12V	+12VSB
120mVp-p	120mVp-p

6.8 Timing Requirements

These are the timing requirements for the power supply operation. Table below shows the timing requirements for the power supply being turned on and off two different ways; 1) Via the DC input with PSON held low; 2) Via the PSON signal with the DC input applied.

Table 21 Timing Requirements

Item	Description	Min	Nom	MAX	UNITS
T12V_rise	Output voltage rise time from 10% to 90% of normal regulation.	10		30	ms
T12Vsb_rise	Output voltage rise time from 10% to 90% of normal regulation.	10		30	ms
Toff_latch	This is the time the PSU must stay off when being powered off with loss of DC input. Both outputs must meet this OFF time; 1) whenever PWOK is de-asserted for the 12Vmain output; 2) whenever the 12Vstby output drops below regulation limits	500		1000	ms
Tsb_on_delay	Delay from DC being applied to 12VSBbeing within regulation.			1000	ms
Tdc_on_delay	Delay from DC being applied to all output voltages being within regulation (PSON_L = Low).			2000	ms
Tpwok_holdup	Delay from loss of DC to de-assertion of PWOK at -48VDC input, 70% load.	0.5			ms
T_holdup	Time the 12Vmain output voltage stays within regulation after loss of DC (-48VDC input, 70% load).	1			ms
Tpson_off_delay	Delay from PSON# de-asserted to power supply turning off	2	3	4	ms
Tpson_on_delay	Delay from PSON# active to output voltages within regulation limits.	5	35	70	ms
Tpson_pwok	Delay from PSON# deactivate to PWOK being de-asserted.		1	2	ms
Tpwok_on	Delay from output voltages within regulation limits to PWOK asserted at turn on.	100	150	200	ms
Tpwok_off	Delay from PWOK de-asserted to output voltages dropping out of regulation limits at -48VDC input, 70% load.	0.15			ms

Tpwok_low	Duration of PWOK being in the de-asserted state during an off/on cycle using DC or the PSON signal.	100			ms
Tsb_vout	Delay from 12VSB being in regulation to O/Ps being in regulation at DC turn on.	50		500	ms
T12VSB_holdup	Time the 12VSB output voltage stays within regulation after loss of DC.	2			ms

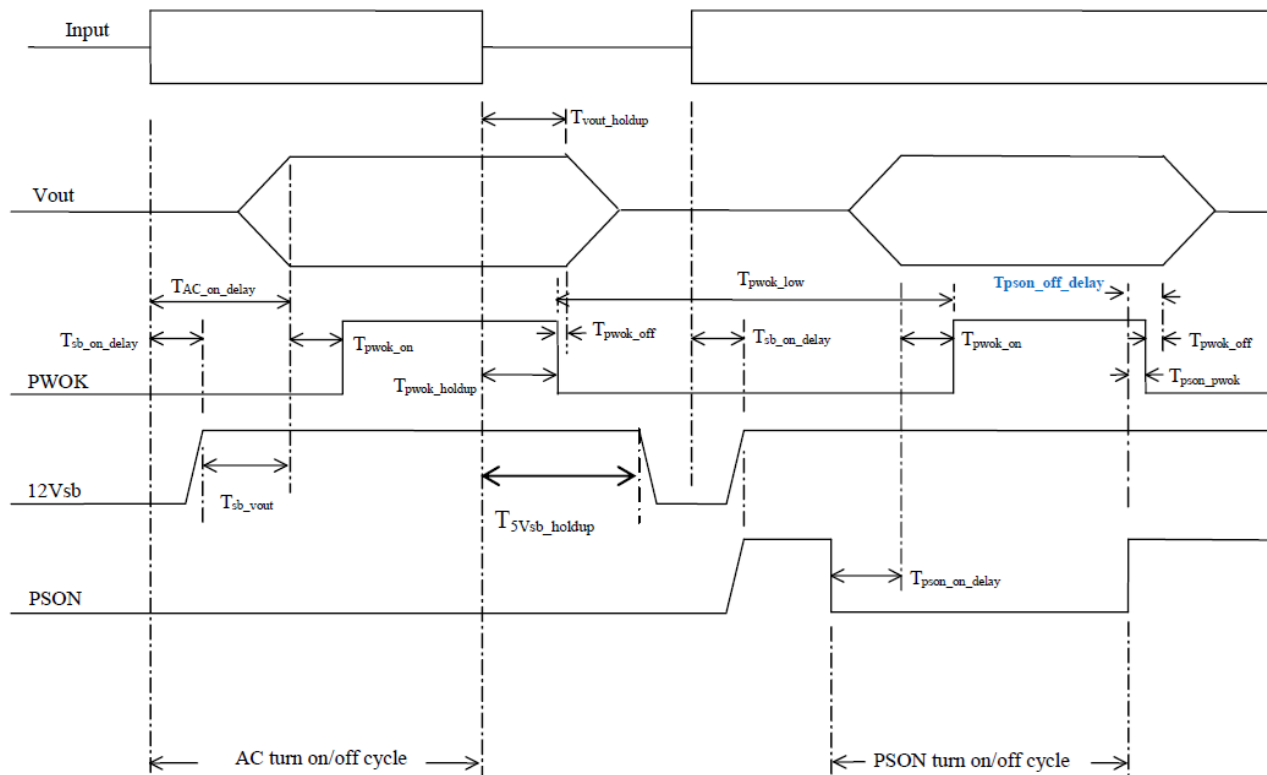

Figure 3 Turn On/Off Timing (Power Supply Signals)

7. Protection Circuits

Protection circuits inside the power supply shall cause only the power supply's main outputs to shut down. If the power supply latches off due to a protection circuit tripping, a DC cycle OFF for 15sec and a PSON# cycle HIGH for 1 second shall be able to reset the power supply.

7.1 Over Current Protection & SCP (OCP & SCP)

The power supply shall have over current protection (OCP), as defined in **Table 22** below.

If the current limits are exceeded the power supply shall shutdown and latch off. The latch will be cleared by a DC power interruption or by toggling the PSON input.

12VSB will be auto recovered after the over current condition is removed.

Table 22 OCP Requirements

-40VDC -- -72VDC		Current Threshold		Trip Timing		Comments
Spec	Description	MIN	MAX	MIN	MAX	
Fast OCP	Over current protection	140A	160A	100us		150us/160A typical
Fast OCW	Fast over current warning (SMBAlert#)	125A	140A	5us	20us	135A typical
Slow OCP	Slow over current protection (shutdown and latch after MIN/MAX timing)	115A	125A	10msec	50msec	30msec/120A typical
Slow OCW	Slow over current warning (SMBAlert#)	110A	120A	10msec	15msec	12msec/116A typical
20 sec OCP	Very slow over current protection (shutdown and latch)	106A	112A	20sec		22sec/109A typical
OCPstby	Stby over current protection (shutdown, hiccup mode)	4.5A	5.5A	1ms	100ms	10ms/5A typical

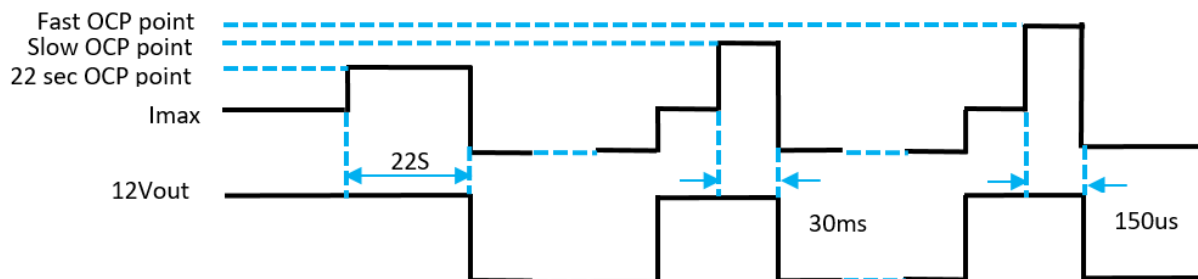

Figure 4 12V OCP latch off

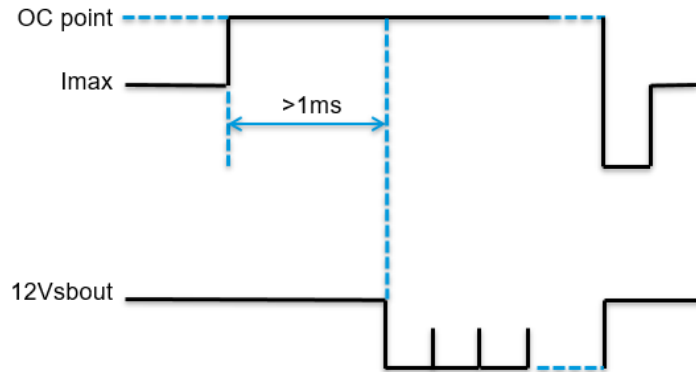

Figure 5 12Vsb OCP hiccup

7.2 Over Voltage Protection (OVP)

The power supply over voltage protection (100us delay time, typical) shall be locally sensed. The power supply shall shutdown and latch off after 12V over voltage condition occurs. This latch shall be cleared by toggling the PSON# signal or by a DC power interruption. The values are measured at the output of the power supply's connectors.

12VSB will automatic recovery after OVP.

Table 23 Over Voltage Protection (OVP) Limits

Output Voltage	MIN (V)	MAX (V)
+12V	13.3	14.5
+12VSB	13.3	14.5

7.3 Under Voltage Protection (UVP)

Both main and standby outputs are monitored.

The main output will latch off if the main output voltage falls below 10V (typically in an overload or short circuit condition). The latch can be unlocked by disconnecting the supply from the DC mains or by toggling the PSON# signal.

If the standby output falls below min regulation main output is disabled to protect the system. Standby UVP is hiccup mode.

12VSB will UVP and will automatic recovery when the output voltage falls below 10V.

7.4 Over Temperature Protection (OTP)

The power supply will be protected against over temperature conditions caused by loss of fan cooling or excessive ambient temperature. In an OTP condition the PSU will shut down. When the power supply temperature drops to within specified limits, the power supply shall restore power automatically.

8. Control and Indicator Functions

The following sections define the input and output signals from the power supply.

Signals that can be defined as low true use the following convention: Signal# = low true.

8.1 PSON# Input Signal

The PSON# signal is required to remotely turn on/off the power supply. PSON# is an active low signal that turns on the +12V power rail. When this signal is not pulled low by the system, or left open, the outputs (except the +12VSB) turn off. This signal is pulled to a standby voltage by a pull-up resistor.

Table 24 PSON# Signal Characteristic

Signal Type	Accepts an open collector/drain input from the system. Pull-up to 3.3V with a 10K resistor located in power supply.	
PSON# = Low	ON	
PSON# = High or Open	OFF	
	MIN	MAX
Logic level low (power supply ON)	0V	1.0V
Logic level high (power supply OFF)	2.0V	3.46V
Source current, Vpson = low		4mA

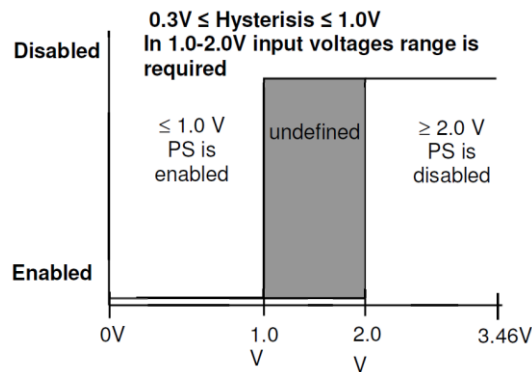

Figure 6 PSON# Required Signal Characteristic

8.2 PWOK (Power OK) Output Signal

PWOK is a power OK signal and will be pulled HIGH by the power supply to indicate that all the outputs are within the regulation limits of the power supply. When any output voltage falls below regulation limits sufficiently or when DC power has been removed for a time sufficiently long so that power supply operation is no longer guaranteed, PWOK will be de-asserted to a LOW state. The start of the PWOK delay time shall be inhibited once any power supply output is in current limit.

Table 25 PWOK Signal Characteristics

Signal Type	Pull-up to 3.3V located in the power supply	
PWOK = High	Power OK	
PWOK = Low	Power Not OK	
	MIN	MAX
Logic level low voltage, Isink=400uA	0V	0.4V
Logic level high voltage, Isource=200uA	2.4V	3.46V
Sink current, PWOK = low		400uA
Source current, PWOK = high		2mA

8.3 SMBAlert# Signal

This signal indicates that the power supply is experiencing a problem that the user should investigate. This shall be asserted due to Critical events or Warning events. By default, the SMBAlert# signal is asserted for the following cases.

1. STATUS_INPUT (UV Fault bit): input voltage drops to 0V of the PSU for > 2ms.
2. STATUS_IOUT (Iout OC Warning bit): Output current exceeds the PSU capability, but PSU has not shutdown.
3. STATUS_TEMPERATURE (OT Warning): Thermal sensor for PS inlet temperature or on a hot spot inside the PSU has exceeded its warning temperature.

This signal is to be asserted in parallel with LED turning solid Amber or blink Amber.

Table 26 SMBAlert # Signal Characteristics

Signal Type (Active Low)	Open collector / drain output from power supply, meet below if pull up to 3.3V with 4.7K resistor in system	
Alert# = High	OK	
Alert# = Low	Power Alert to system	
	MIN	MAX
Logic level low voltage, Isink=4 mA	0 V	0.4 V
Logic level high voltage, Isink=50 μ A	2.4V	3.46 V
Sink current, Alert# = low		4 mA
Sink current, Alert# = high		50 μ A

8.4 PRESENT_L OUTPUT

The PRESENT_L pin is wired through a 100 Ohms resistor to internal GND within the power supply. This pin does indicate that there is a power supply present in this system slot. An external pull-up resistor must be added within the application. Current into PRESENT_L should not exceed 5 mA to guarantee a low-level voltage if power supply is seated.

8.5 12V Remote Sense

The main output has sense lines implemented to compensate for voltage drop on load wires in both positive and negative path. The maximum allowed voltage drop is about 200 mV on the positive rail and 50 mV on the GND rail.

- a) When one or more remote sense lines are opened, output voltage measured at the power supply output connector must be maintained within regulation defined, plus or minus an additional 250mV+-50mV.
- b) If the REMOTE SENSE+ is shorted to Ground, the power supply will shut down

8.6 Hot Standby In/out

The hot-standby operation is an operating mode allowing to further increase efficiency at light load conditions in a redundant power supply system. Under specific conditions one of the power supplies is allowing to disable its DC/DC stage. This will save the power losses associated with this power supply and at the same time the other power supply will operate in a load range having a better efficiency. To enable the hot standby operation, the HOTSTANDBYEN_H and the ISHARE pins need to be interconnected between the power supplies. A power supply will only be allowed to enter the hot-standby mode, when the HOTSTANDBYEN_H pin is high, the load current is low, see Figure 8, and the supply is allowing to enter the hot-standby mode by the system controller via the appropriate I2C command (by default disabled). The system controller needs to ensure that only one of the power supplies is allowing to enter the hot-standby mode.

If a power supply is in a fault condition, it will pull low its active-high HOTSTANDBYEN_H pin which indicates to the other power supply that it is not allowed to enter the hot-standby mode or that it needs to return to normal operation should it already have been in the hot-standby mode.

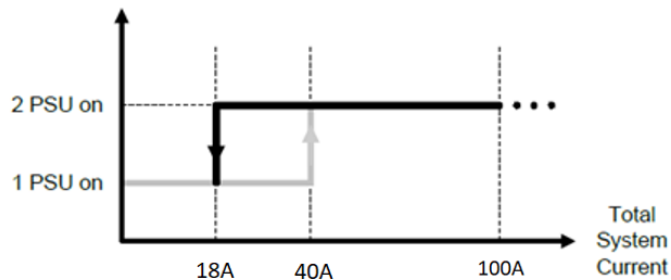

Figure 7 Hot-standby enable/disable typical current thresholds

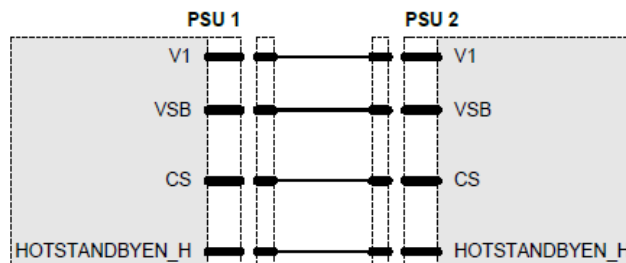

Figure 8 Recommended hot-standby configuration

9. Environmental Requirements

9.1 Temperature

Minimum operating ambient: -5°C

Maximum operating ambient: +55°C for full load (Normal airflow)

+45°C for full load (Reverse airflow)

Non-operating ambient: -40°C to +70°C (Maximum rate of change of 20°C/hour)

Note:

1. Max +65°C for 900W (Normal airflow)
2. Max +55°C for 900W (Reverse airflow)

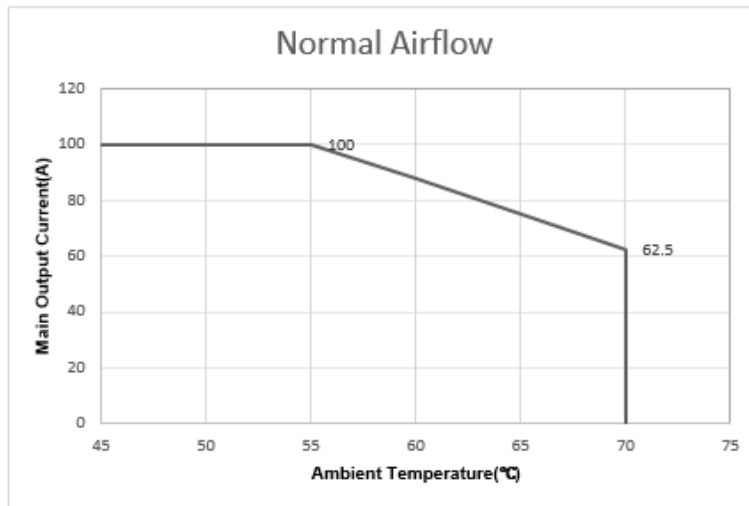

Figure 9 Iout derating with temperature (Normal Airflow)

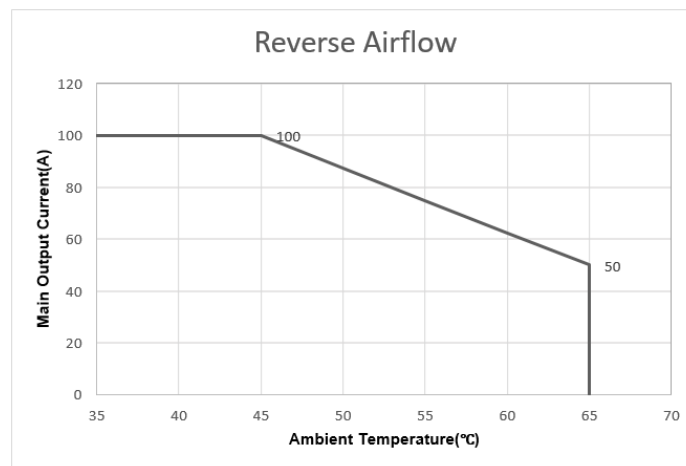

Figure 10 Iout derating with temperature (Reverse Airflow)

9.2 Humidity

Operating: To 95% relative humidity (non-condensing)

9.3 Altitude

Operating: Up to 5000m for safety creepage and clearance, meet Flex components derating up to 1000m and meet components rating for 3050m at full load condition.

Non-operating: to 15200m

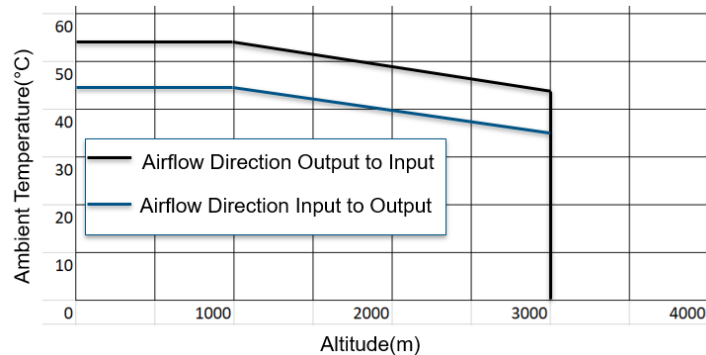

Figure 11 Temperature derating with altitude (100% load)

9.4 Mechanical Shock

PARAMETER	DESCRIPTION/CONDITION
Half-Sine Shock, Non-Operating	11ms, 30g peak, 10shocks/direction, total 6 directions
Half-Sine Shock, Operating	IPC-9592B 11ms, 30g, 3 shocks/axis, total 3axis

9.5 Vibration

PARAMETER	DESCRIPTION/CONDITION
Sinusoidal Vibration, Non-Operating	2Hz~9Hz, 3.5 mm; 9Hz~200Hz, 10m/s ² ; 200Hz~500Hz, 15m/s ² , 1oct/min, 5 sweep/axis
Sinusoidal Vibration, Operating	1g peak, sweep 5 to 500Hz, 1oct/min, 5 sweep/axis
Random Vibration, Operating	IPC-9592B 2.4Grms, 10~500Hz, 30min/axis
Random Vibration, Non-Operating	5Hz@0.01g ² /Hz to 20Hz@0.02g ² /Hz (slope up), 20Hz to 500Hz@0.02g ² /Hz (flat), 3.13Grms, 30min/axis, total 3 axis

Thermal Shock (Shipping)

Non-operating: -40°C to +70°C, 50 cycles, 30°C/min. ≥ transition time ≥ 15°C/min., duration of exposure to temperature extremes for each half cycle shall be 30 minutes.

10. Firmware Requirements

10.1 PMBus

Refer to SPEC of PMBus Rev1.2.

10.2 Power Measure Preciseness

The power supply must meet below power measure preciseness requirements for the DC input voltage

Item	Description	Min	Nom	MAX	UNITS
Pin	Input power (Pin > 250W)	-5%		+5%	
Vin	Input RMS voltage	-2		+2	VDC
Iin	Input RMS current (Iin > 5.8A)	-5%		+5%	
Pout	Output power (Pout > 600W)	-3%		+3%	
	Output power (50W < Pout ≤ 600W)	-18		+18	W
12Vout	Output voltage	-0.2		+0.2	VDC
12VIout	Output current (Iout > 30A)	-2%		+2%	
	Output current (5 < Iout ≤ 30A)	-0.6		+0.6	A
Tamb	Inlet temperature	- 4		+ 4	°C

10.3 Summary of SMBus/PMBus Commands

Code	Pages	Command	SMBus Transaction Type Status bit mapping
03h	NA	CLEAR_FAULTS	Send Byte w/PEC
05h	NA	PAGE_PLUS_WRITE (used with STATUS_WORD, STATUS_IOUT, STATUS_INPUT, STATUS_TEMPERATURE)	Block Write w/PEC Used with STATUS_INPUT, STATUS_TEMPERATURE, STATUS_IOUT
06h	NA	PAGE_PLUS_READ (used with STATUS_WORD, STATUS_IOUT, STATUS_INPUT, STATUS_TEMPERATURE)	Write Block Read Block Process Call w/PEC Used with STATUS_INPUT, STATUS_TEMPERATURE, STATUS_IOUT, STATUS_WORD
19h	NA	CAPABILITY	Read Byte w/PEC
1Ah	NA	QUERY (used with any command)	Block Write Block Read Process Call w/ PEC
1Bh	NA	SMBALERT_MASK (used with STATUS_INPUT, STATUS_TEMPERATURE, STATUS_IOUT)	Reading: Write Block Read Block Process Call w/PEC Writing: Write Word
20h		VOUT_MODE	Read/Write Byte w/PEC
3Ah	NA	FAN_CONFIG_1_2	
3Bh	NA	FAN_COMMAND_1	
79h	00h, 01h	STATUS_WORD	Read Word w/PEC
(Low) 6		OFF	PS off

4		IOUT_OC	Indeterminate (Use STATUS_IOUT)
2		TEMPERATURE	Indeterminate (Use STATUS_TEMPERATURE)
3		VIN_UV	Indeterminate (Use STATUS_INPUT)
1		CML	
(High) 7		VOUT	Failure
6		IOUT/POUT	Indeterminate (Use STATUS_IOUT)
5		INPUT	Indeterminate (Use STATUS_INPUT)
4		MFR_SPECIFIC (Incompatible Power Supply)	
3		POWER_GOOD#	
2		FANS	Indeterminate (Use STATUS_FANS)
7Ah	NA	STATUS_VOUT	Read Byte w/PEC
7		VOUT_OV_FAULT	Failure
4		VOUT_UV_FAULT	Predictive failure
7Bh	00h, 01h	STATUS_IOUT	Read Byte w/PEC
7		Iout OC fault	Failure
5		No support	No support
1		Pout OP fault	Failure
0		No support	No support
7Ch	00h, 01h	STATUS_INPUT	Read Byte w/PEC
5		No support	No support
4		Vin UV fault	DC Loss
3		Unit off for insufficient input	DC Loss
1		No support	No support
0		No support	No support
7Dh	00h, 01h	STATUS_TEMPERATURE	Read Byte w/PEC
7		OT fault	Fault
6		OT warning	Predictive fault
81h	00h	STATUS_FANS_1_2	Read Byte w/PEC
7		Fan 1 fault	Failure
6		Fan 2 fault	Failure
5		Fan 1 warning	Predictive failure
4		Fan 2 warning	Predictive failure
88h	NA	READ_VIN	Read Word w/PEC
89h	NA	READ_IIN	Read Word w/PEC
8Bh	NA	READ_VOUT	Read Word w/PEC
8Ch	NA	READ_IOUT	Read Word w/PEC
8Dh	NA	READ_TEMPERATURE_1 (Ambient)	Read Word w/PEC
8Eh	NA	READ_TEMPERATURE_2 (Hot Spot)	Read Word w/PEC
90h	NA	READ_FAN_SPEED_1	Read Word w/PEC
96h	NA	READ_POUT	Read Word w/PEC
97h	NA	READ_PIN	Read Word w/PEC
98h	NA	PMBUS_REVISION	Read Byte w/PEC
9Ah	NA	MFR_MODEL	Block Read
9Bh	NA	MFR_REVISION	Block Read

9Fh	NA	APP_PROFILE_SUPPORT	Read Byte w/PEC
A6h	NA	MFR_IOUT_MAX	Read Word w/PEC
A7h	NA	MFR_POUT_MAX	Read Word w/PEC
C0h	NA	MFR_MAX_TEMP_1 (Ambient)	Read Word w/PEC
C1h	NA	MFR_MAX_TEMP_2 (hot Spot)	Read Word w/PEC
D0h	NA	MFR_COLD_REDUNDANCY_ CONFIG	Read/Write Byte w/PEC
D1h – D3h		reserved	
D4h	NA	MFR_HW_COMPATIBILITY	Read Word w/PEC
D5h	NA	MFR_FWUPLOAD_CAPABILI TY	Read Byte w/PEC
D6h	NA	MFR_FWUPLOAD_MODE	Read/Write Byte w/PEC
D7h	NA	MFR_FWUPLOAD	Block Write w/ PEC (size = block size from image header)
D8h	NA	MFR_FWUPLOAD_STATUS	Read Word w/PEC
D9h	NA	MFR_FW_REVISION	Block Read w/PEC (3 bytes)
DEh	00h, 01h,02h	Hot-Standby	Read/Write Word w/PEC
0		0=disable(default), 1=enable	HS select RW
1		0=low, 1=high	HS enable line RO
2		0=not active, 1=active	HS status RO
3-F			Reserved RO
E5h	NA	MFR_BLACKBOX	Block Read w/ PEC (237 bytes)
E6h	NA	MFR_REAL_TIME_BLACK_B OX	Block Write/Read w/ PEC (4 bytes)
E7h	NA	MFR_SYSTEM_BLACK_BOX	Block Write/Read w/ PEC (40 bytes)

10.4 Support the Both Operation With and Without PEC

Example:

Read work without PEC

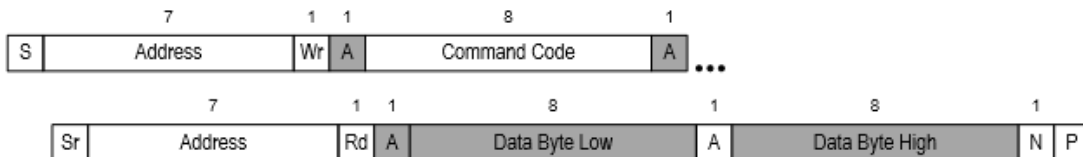

Read word with PEC

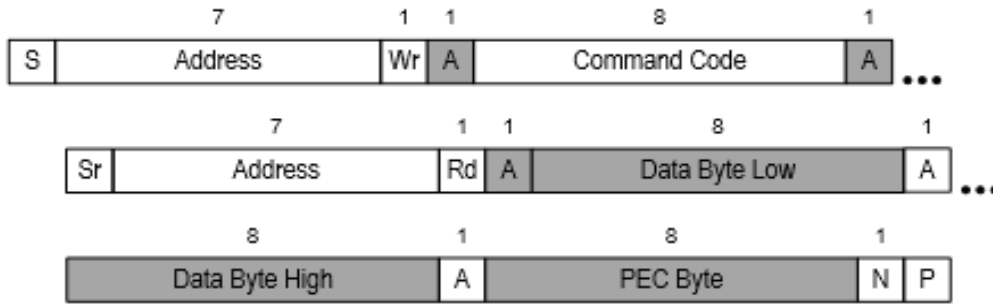

Write word without PEC

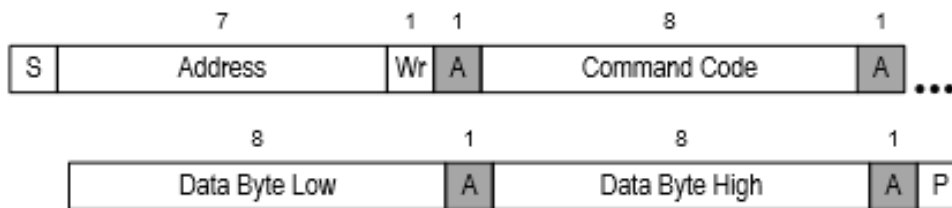

Write word with PEC

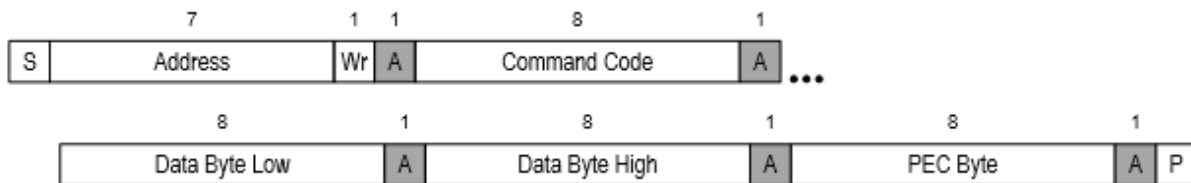

11. Reliability

11.1 Component De-rating

The components in this product are required to comply with Flex internal requirement. Any exceptions are subject to final approved by Flex Design Engineering.

11.2 Life Requirement

The power supply shall support **5 years** calculated life under the following conditions.

Normal airflow testing condition:

- -53VDC input
- 55°C inlet temperature
- 20% of the time at 20% load; 80% of the time at 80% load

Reverse airflow testing condition:

- -53VDC input
- 45°C inlet temperature
- 20% of the time at 20% load; 80% of the time at 80% load

11.3 Mean Time Between Failures (MTBF)

Normal airflow:

The power supply shall have a minimum MTBF at continuous operation of 250,000 hours at the condition of -53VDC, 80% load and 50°C, as calculated by Telcordia SR-332 Issues 2.

Reverse airflow:

The power supply shall have a minimum MTBF at continuous operation of 250,000 hours at the condition of -53VDC, 80% load and 40°C, as calculated by Telcordia SR-332 Issues 2.

12. Ecology Requirements

- Directive of the European Parliament and of the Council on the Restriction of the Use of Certain Hazardous Substances in Electrical and Electronic Equipment, 2011/65/EU, June 2011 (RoHS Directive) and 2015/863/EU, June 2015 (addition of four phthalates)
- Regulation of the European Parliament and of the Council on the Registration, Evaluation, Authorization and Restriction of Chemicals, 1907/2006/EC, December 2006 (REACH)

13. Regulatory Requirements

Intended Application – This product was evaluated as Information Technology Equipment (ITE), which may be installed in offices, schools, computer rooms, and similar commercial type locations. The suitability of this product for other product categories and environments, other than an ITE application, may require further evaluation.

13.1 Product Safety Compliance

UL&cUL: UL60950-1/CSA 60950-1 / UL62368-1 (USA / Canada)

CB: IEC60950-1 / IEC62368-1/EN60950-1 / EN62368-1 (EN60950-1/EN62368-1 covered by CB)

CE - Low Voltage Directive 2014/35/EU (Europe)

CQC: GB 4943.1

EAC(CU): IEC 60950-1

13.2 Product EMC Compliance – Class A Compliance

Note: The product is required to comply with Class A emission requirements (designed with 6dB margin) as the end system that it is configured into is intended for a commercial environment and marketplace.

FCC /ICES-003 part 15 - Emissions (USA/Canada) Verification

CISPR 32 – Emissions (International)

EN55032 - Emissions (Europe)

EN55024 - Immunity (Europe)

- EN61000-4-2 Electrostatic Discharge, 8kV contact discharge voltage and 15kV air discharge voltage
- EN61000-4-3 Radiated RFI Immunity
- EN61000-4-4 Electrical Fast Transients, common mode 1.0 kV and differential mode 1.0 kV
- EN61000-4-5 Electrical Surge, common mode 1.0 kV and differential mode 1.0 kV
- EN61000-4-6 RF Conducted Immunity, 10Vrms
- EN61000-4-8 Power Frequency Magnetic Fields, 30A/m

EN61000-3-3 - Voltage Flicker (Europe)

AS/NZS CISPR 32 (Australia / New Zealand)

GB 17625.1, GB/T 9254

13.3 NEBS Compliance

Note: The product is designed to meet below NEBS requirements

GR-63-CORE (Issue 5, Short term operating temperature)

PSU can operate at rated temperature+10°C max with output power derating (refer to PSU Spec figure 9 and figure 10 in spec), it will help system pass GR-63-CORE short term high operating temperature requirement.

GR-1089-CORE (Issue 7, EMC)

- ESD, meet GR-1089-CORE, normal operation table 2-1, contact ESD 8KV and air ESD 15KV for DC input (type 8 port type)
- EFT, meet GR-1089-CORE, 1KV EFT on DC input (type 8 port type)
- Radiated emission, meet GR-1089-CORE radiated emission requirement for class A table 3-1
- Conducted emission, meet GR-1089-CORE conducted emission requirement for class A table 3-3 for DC port
- Radiated immunity, meet GR-1089-CORE conducted immunity requirement table

3-7 for DC port

- Conducted immunity, meet GR-1089-CORE radiated immunity 8.5V/M from 10KHz to 10GHz
- Surge, meet GR-1089-CORE table 4-2 number 23 on DC input (type 8 port type), 1KV surge with 1.2/50us voltage and 2 ohms internal impedance without external SPD