

OPEN

Compute Project

Flatbed Design Specification

Revision 0.05

Author: Scott McCauley (scottmcc@google.com)

Author: Nate Klein (nxk@google.com)

Author: Bill Barry (williambarry@google.com)

1. License

Contributions to this Specification are made under the terms and conditions set forth in Open Web Foundation Contributor License Agreement (“OWF CLA 1.0”) by:

Google, Inc.

You can review the signed copies of the applicable Contributor License(s) for this Specification on the OCP website at <http://www.opencompute.org/products/specsanddesign>

Usage of this Specification is governed by the terms and conditions set forth in Open Web Foundation Final Specification Agreement (“OWFa 1.0”).

You can review the applicable Specification License(s) executed by the above referenced contributors to this Specification on the OCP website at <http://www.opencompute.org/participate/legal-documents/>

Note: The following clarifications, which distinguish technology licensed in the Contribution License and/or Specification License from those technologies merely referenced (but not licensed), were accepted by the Incubation Committee of the OCP:

CONTRIBUTORS AND LICENSORS OF THIS SPECIFICATION MAY HAVE MENTIONED CERTAIN TECHNOLOGIES THAT ARE MERELY REFERENCED WITHIN THIS SPECIFICATION AND NOT LICENSED UNDER THE OWF CLA OR OWFa. THE FOLLOWING IS A LIST OF MERELY REFERENCED TECHNOLOGY:

INTELLIGENT PLATFORM MANAGEMENT INTERFACE (IPMI)

I2C TRADEMARK OF PHILLIPS SEMICONDUCTOR.

SMBus

OpenBMC

REST API

NC-SI

ATX

EPS12V

MAX31790 (Maxim IC)

TM4C129 (Texas Instruments)

ISO1540 (Texas Instruments)

PCA9548 (Texas Instruments, Phillips Semiconductor)

TCA9555 (Texas Instruments, Phillips Semiconductor)

LTC4316 (Linear Technology)

ADUM1250 (Analog Devices)

24C04 EEPROM

Molex Minitfit

Molex Microfit

Tyco Connectivity 5499910-1

Molex 90130-1210

Samtec HW-TH series

IMPLEMENTATION OF THESE TECHNOLOGIES MAY BE SUBJECT TO THEIR OWN LEGAL TERMS.

NOTWITHSTANDING THE FOREGOING LICENSES, THIS SPECIFICATION IS PROVIDED BY OCP "AS IS" AND OCP EXPRESSLY DISCLAIMS ANY WARRANTIES (EXPRESS, IMPLIED, OR

OTHERWISE), INCLUDING IMPLIED WARRANTIES OF MERCHANTABILITY, NON-INFRINGEMENT, FITNESS FOR A PARTICULAR PURPOSE, OR TITLE, RELATED TO THE SPECIFICATION. NOTICE IS HEREBY GIVEN, THAT OTHER RIGHTS NOT GRANTED AS SET FORTH ABOVE, INCLUDING WITHOUT LIMITATION, RIGHTS OF THIRD PARTIES WHO DID NOT EXECUTE THE ABOVE LICENSES, MAY BE IMPLICATED BY THE IMPLEMENTATION OF OR COMPLIANCE WITH THIS SPECIFICATION. OCP IS NOT RESPONSIBLE FOR IDENTIFYING RIGHTS FOR WHICH A LICENSE MAY BE REQUIRED IN ORDER TO IMPLEMENT THIS SPECIFICATION. THE ENTIRE RISK AS TO IMPLEMENTING OR OTHERWISE USING THE SPECIFICATION IS ASSUMED BY YOU. IN NO EVENT WILL OCP BE LIABLE TO YOU FOR ANY MONETARY DAMAGES WITH RESPECT TO ANY CLAIMS RELATED TO, OR ARISING OUT OF YOUR USE OF THIS SPECIFICATION, INCLUDING BUT NOT LIMITED TO ANY LIABILITY FOR LOST PROFITS OR ANY CONSEQUENTIAL, INCIDENTAL, INDIRECT, SPECIAL OR PUNITIVE DAMAGES OF ANY CHARACTER FROM ANY CAUSES OF ACTION OF ANY KIND WITH RESPECT TO THIS SPECIFICATION, WHETHER BASED ON BREACH OF CONTRACT, TORT (INCLUDING NEGLIGENCE), OR OTHERWISE, AND EVEN IF OCP HAS BEEN ADVISED OF THE POSSIBILITY OF SUCH DAMAGE.

License	2
Scope	6
Overview	7
Design Outline	7
Rack Compatibility	9
SLED Thermal Design Requirements	9
Control Loop Schemes	9
Tractor-Master	9
BMC-Master	9
BMC-Tractor	10
Data Center Environmental Conditions	10
Server Operational Conditions	10
Thermal Kit Requirements	10
SLED Rear Power I/O and Interconnect	11
Overview of Functionality and Population Options	11
Rear Side Connectors	11
Tractor PCBA Physical Specifications	11
Tractor Adapter PCBA Block Diagrams	11
Placement and Form Factor	13
PCB Stack-Up	13
Tractor PCBA Control and Status Sub-System	13
Comms I2C Interface	13
I2C Device Address Translation	14
Comms Connector and Cable	14
Programmable Devices and Configuration EEPROM	15
Tractor PCBA Power Path	16
Tractor Power Requirements	16
Inputs	16
Operating Voltage Ranges	16
Shortpin Function, Safe Removal	17

Input Fusing	17
Outputs	17
Monitoring	17
ON/OFF Sequencing Control	17
Tractor PCBA Fan Power and Control	18
Tractor PCBA Thermal Sensing Support	18
Tractor PCBA Expansion Connector	19
SLED Documentation Requirements	21
SLED Environmental Requirements	21
SLED Regulatory Compliance	21
SLED Reliability and Quality	22
Flatbed PAYLOAD Specification Requirements	22
Power Inputs	22
I2C/SMBus Requirements	22
Address Space on Expansion Connectors	22
I2C Multiplexer Usage	23
BMC	24
BMC NC-SI	24
BMC I2C	24
Timebase Accuracy	24
PCIe Slots	25
BIOS	25
Mechanicals	25
Airflow	25
Dimensions	25
Preferred Layouts	25
Thermals	26
Standards Compliance	26
Quality and Reliability	26
Appendix A: Flatbed Standards Compliance	26

Materials	26
Basic Compliance Requirements	26
Safety	26
EMC	26
Emissions	27
Immunity	27
Country Specific EMC Requirements	27
General Compliance	28
Product Compliance Requirements	28
Appendix B: Flatbed Quality and Reliability	28
Specification Compliance	29
Labels and Markings	29
Change Orders	30
Failure Analysis	30
Warranty	30
MTBF Requirements	30
Control Change Authorization and Revision Control	30
PCB Tests	30
Secondary Components	30
Prescribed Materials	30
Disallowed Components	30
Capacitors & Inductors	31
Component De-rating	31
Revision History	31

2. Scope

This document defines the technical specifications for the Flatbed 48V Rack to 12V IT Payload Adapter (“Flatbed”) used in Open Compute Project OpenRack V2.0 (“ORv2”) systems.

The intention is to provide a set of high-level requirements for Flatbed Sled Sub-Components that ensures compatibility with the ORv2 rack standard and datacenter environmental constraints (primarily thermal). In addition, the Flatbed partitioning of power and cooling control is intended to present a common interface across payload types for monitoring and control loop software. Power monitoring and thermal control software can be implemented in a flexible manner, for example:

- Within an OpenBMC framework running on the Flatbed sled IT Gear Payload

- Utilizing a standalone microcontroller on the Flatbed adaptor PCBA(s)

This specification does not attempt to completely define the detailed implementation of Flatbed sled designs or submodules, recognizing that many distinct designs may be required to support the desired diversity of Payloads and deployments.

Overview

The Flatbed 48V Rack to 12V IT Payload Adapter provides a standardized method of supporting both standard-compliant motherboards (such as ATX/microATX or Open Compute Project) and certain proprietary IT payloads within an ORv2-compliant rack with 48V internal power distribution.

Why 48V? A 48V-native power distribution within the rack can provide the opportunity for increased end-to-end power conversion and delivery efficiency, while allowing disaggregation of power conversion and battery backup functions from individual server sleds. This in turn can lead to higher resource utilization and lower integrated rack cost by better matching available power to load requirements. Redundant power train components in the rack can also be serviced without affecting individual server operation.

However, the majority of currently available servers and other IT payloads require 12V inputs.

Flatbed **streamlines** the use of both pre-existing industry standard servers and new, novel 12V payloads in a 48V rack architecture well suited to large warehouse-scale datacenter deployments. Both HW and SW re-use is enabled by providing a “toolkit” to bridge between IT Gear payload and the datacenter ecosystem using defacto- and industry-standard interfaces (I2C, PCIe, ORv2, IPMI FRU info formats, etc.).

Flatbed also provides a **migration path** for datacenters to move to a 48V rack-level power distribution architecture to better accommodate future high-power rack loads, while still supporting proven 12V IT Gear payloads. By forming a “wrapper” around existing 12V payloads, existing or future 48V-to-PoL powertrain payloads can also be integrated in the same rack in a non-homogeneous fashion.

The following specification covers three distinct areas with different scopes; the following keywords are used in the document to indicate the scope of a given section:

1. **SLED**
2. **Tractor PCBA**
3. **Payload**

Design Outline

A Flatbed IT Gear sled is comprised of several sub-components, generally selected from a toolbox of general-purpose adaptors. The ORv2-compliant sheetmetal tray provides an interface to the mechanical features of the ORv2 rack and physical support for the other components. As an example, these components will include the following:

- The IT Gear payload
- A “Tractor” PCBA used as a power adaptor and as an interface to sled-level fans and thermal sensors

- Fans, cooling shrouds, and heatsinks to implement cooling of the payload
- Cabled interconnect between the individual subcomponents

The Flatbed sheetmetal tray can be of any width, depth, and height supported by the ORv2 specification. Implementation examples and details in this document will focus primarily on ORv2 “shallow” racks.

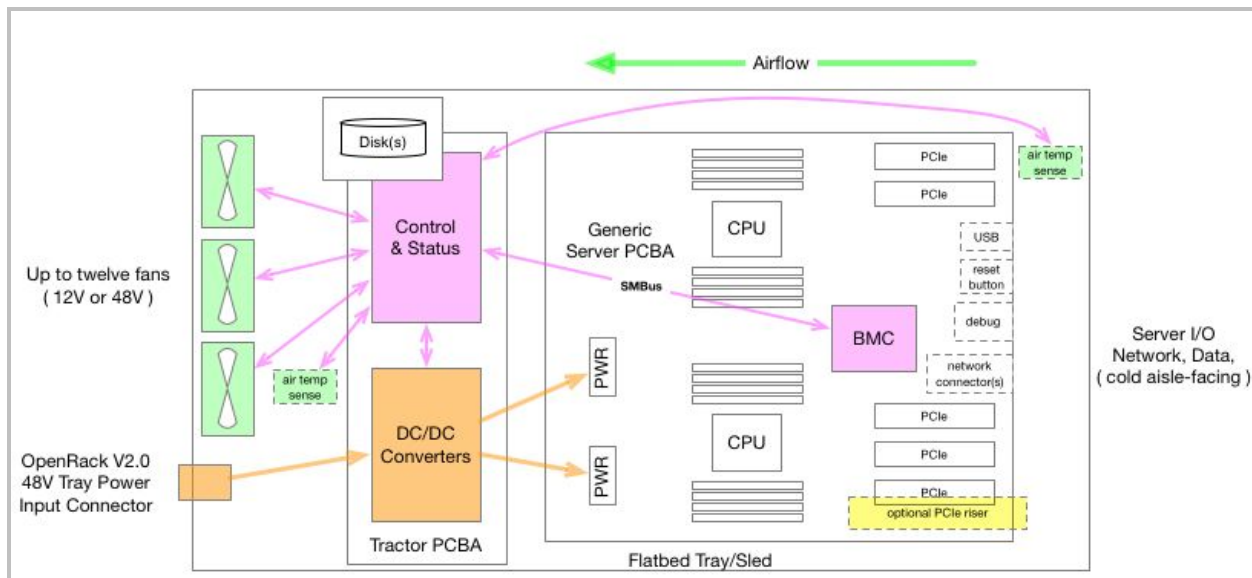

Figure 1: Generic Flatbed Sled

The IT Gear payload is typically a server motherboard populated with CPU(s), memory, NIC(s) and any other communications interface cards. Any I/O for users or cabled connectivity to other gear is located at the front of the sled. Cooling airflow is from the front to back of the sled; component orientations and placements that support this airflow direction are strongly recommended.

The Tractor PCBA provides power conversion from the ORv2 48V sled connector to the IT Gear Payload. Different Tractor PCBAs can be optimized for cost, capability, and tray width/depth. A minimum subset of Tractor PCBA features will include sled-level thermal controls and power status/consumption monitoring.

Cooling shrouds and component heatsink designs are expected to vary by payload and be closely tied to the actual IT Gear payload requirements, as well as the environmental envelope of the targeted datacenter(s). Flatbed sled and tray height may vary between use cases to accommodate cooling solutions with the desired performance and lifetime TCO (Total Cost of Ownership).

Subcomponents in the Flatbed sled are connected by cable assemblies to maximize flexibility and re-use of the adapter PCBA sub-designs.

3. Rack Compatibility

Flatbed is designed to function in an OCP ORv2.0-compliant rack with 48V power distribution. The Flatbed tray and mechanical features thereof shall be compatible with the OCP ORv2 specification (of the applicable revision level).

Flatbed supports a variety of payload IT sled widths and heights. Flatbed can be designed to fit any allowable rack depth; however, many design details are intended to ease implementation in the ORv2 “modular shallow” IT Gear depth of ~660mm (rack depth nominally 762mm [30.0in] from front to back).

Flatbed requires “front to back” airflow across the IT Gear payload and other supporting PCBAs in the sled, compatible with ORv2 racks.

Flatbed sleds shall comply to the OCP ORv2 specification. In particular, reference the following sections:

- IT Interconnect to the 48V BUSBAR
- 48V IT Tray Power Specification
- Appendix C: 48V IT Tray to IT Gear Interfaces

Additional detailed electrical requirements for power interoperability are outlined in the [Tractor PCBA Power Path](#) section.

Optional features and target capabilities outlined in the ORv2.0 spec remain as such in the Flatbed implementation.

4. SLED Thermal Design Requirements

The aggregated components of the Flatbed sled shall support operation of the paired IT Gear payload within the datacenter thermal environment. This may require different thermal designs depending on payload power levels and the selected form factors of the Flatbed sled. The Flatbed specification does not require a specific cooling design, and can support a variety of heatsinking technologies, including both air and water cooling.

For example, a Flatbed server sled of height 1 Open U (ORU) may require heatpipe or thermosyphon heatsink designs, whereas a lower power server in a sled height of 2 ORU may be adequately cooled by simple passive metal heatsinks and fairings.

Additionally, three distinct thermal control schemes may implemented as described below.

4.1 Control Loop Schemes

4.1.1 Tractor-Master

The Flatbed Tractor PCBA serves as the thermal master:

- Monitors airflow and/or payload temperatures via local and remote cabled sensors
- Controls sled-level fan RPM loops as the master controller.

This scheme is supported by full-featured fan-control ICs coupled to BJT temperature sensors (such as 2N3906 transistors), and does not require a full featured BMC on the payload.

4.1.2 BMC-Master

The Payload BMC serves as the thermal master, primarily using payload resources:

- Monitors payload critical die temperatures directly

- Controls fan RPM settings, and detects fan failure alarms via payload fan control resources
- Tractor fan control and temperature sensing resources may remain unused

This scheme provides a relatively streamlined implementation path for sled thermal control across many different payload types. Changes to BMC firmware may be minimal for some end users.

4.1.3 BMC-Tractor

The Payload BMC serves as the thermal master:

- Monitors payload-level critical die temperatures directly
- Monitors sled-level airflow temperatures and Tractor PCBA critical temperatures via the Tractor Comms connector interface.
- Controls fan RPM settings and detects fan failure alarms via the Tractor Comms connector interface.

This scheme provides an OpenBMC software implementation a relatively consistent sled-level hardware control interface for end users requiring a unified thermal control scheme across many different payload types.

4.2 Data Center Environmental Conditions

Individual end users will require operation over different environmental conditions. The following Flatbed sled system-level parameters must be defined by the end user.

- Operating temperature range
- Operating humidity range
- Maximum operating elevation
- Air temperature rise at a specific (TBD) reference pressure drop

4.3 Server Operational Conditions

Thermal compliance reports for each Flatbed & Payload integrated system shall include one or more of the following:

- Industry-standard or custom load test benchmarks used during thermal characterization
- Individual measured component power levels during thermal characterization (CPU power, DIMM power, etc.)

4.4 Thermal Kit Requirements

The thermal “kit” refers to sled or tray items used primarily for the purpose of thermal management such as:

- Heatsinks and attachment hardware
- Fairings or Ducting
- Fans
- Thermal sensor PCBAs and cables

Thermal kits are strongly encouraged to utilize PCBA mounting features provided for CPU sockets in the CPU vendor reference designs for heatsink attachment.

Thermal kit materials are required to be UL94V0 rated.

Thermal kits must provide thermal monitoring attachment points adequate to mount I2C-interface temperature sensor for the following:

1. Inlet air temperature

2. Exit air temperature for any independent “zones” or plenums at the air exit (upstream of any sled fans at the rear edge of tray)
3. Any additional air temperature zones which thermal simulation or lab measurement shows to be significantly independent of exit air temperature

Note: Payload and Tractor PCBA thermally critical components shall have die-level or PCBA-level temperature sensors as appropriate to implement the chosen sled-level thermal Control Loop Scheme.

5. SLED Rear Power I/O and Interconnect

5.1 Overview of Functionality and Population Options

The Tractor adaptor PCBA(s) must support a wide variety of Payloads. This specification outlines two distinct PCBA power configurations intended to support most currently available off-the-shelf server motherboards:

- Tractor-ATX
 - Power outputs and functionality emulating ATX/EPS12V “silverbox” power supplies
- Tractor-12V
 - Power outputs for 12V-only servers
 - Two separate 12V bulk power domains with stuffing-selectable capacity (240W to 2KW per domain)
 - One 12V_STANDBY power supply output, capable of up to 4A

5.2 Rear Side Connectors

Flatbed sled trays must provide a floating rear power entry connector (aka “busbar clip”) to mate with the horizontal IT Shelf 48V busbar, as detailed in the ORv2 specification Appendix C, Section C.2. This horizontal rear power connector supports live insertion and extraction (hotswap) as referenced in ORv2 48V IT Tray Specification. A shortpin staging length differential from the power contact(s) of at least 0.5mm is recommended.

This floating rear power entry connector is in turn connected to the Tractor PCBA power input via cables or other flexible coupling.

5.3 Intra-Sled Power Interconnect

Board-to-wire connectors and cable harnesses are used to connect Tractor PCBA power outputs to the Payload PCBA power inputs. Molex Minit-fit-series connectors compliant with the ATX and/or EPS12V power supply standards are recommended. The connectors must offer a positive retention latch.

6. Tractor PCBA Physical Specifications

6.1 Tractor Adapter PCBA Block Diagrams

The Tractor PCBA primarily provides power conversion & monitoring, fan control, and temperature sensor interfaces in Flatbed.

Two conceptual block diagram examples of Tractor PCBA designs which can fulfil the specification requirements are shown below:

Tractor-ATX Toplevel Block Diagram

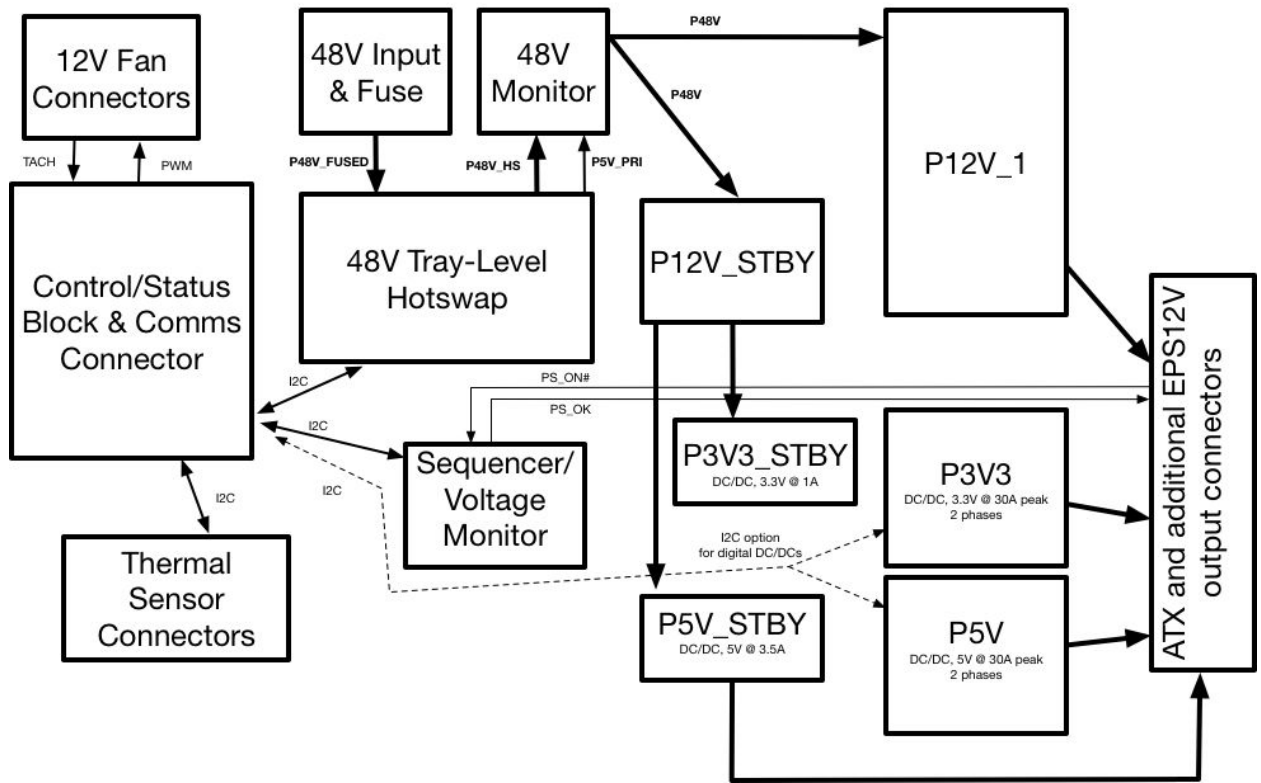

Figure 2: Tractor-ATX Conceptual Block Diagram

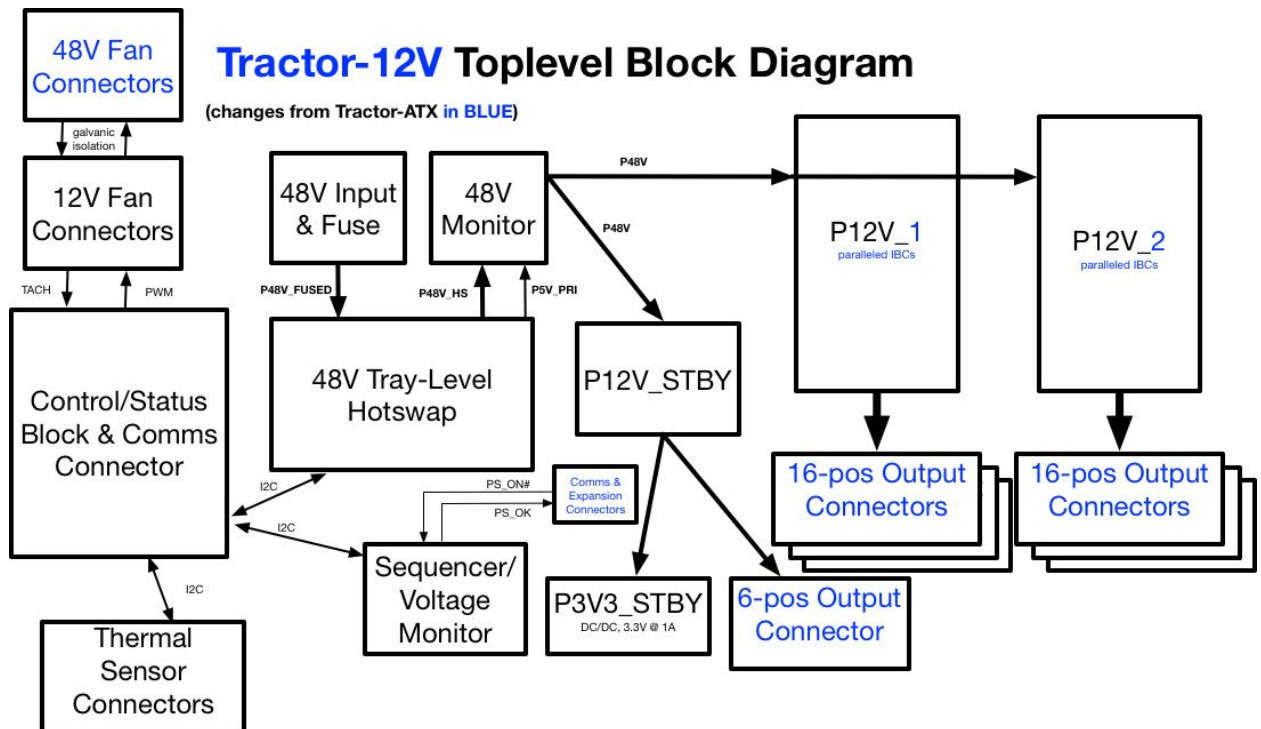

Figure 3: Tractor-12V Conceptual Block Diagram

6.2 Placement and Form Factor

The Flatbed specification does not enforce a single allowed placement or form factor for any sub-component, including the Tractor PCBA. However, the placement of sub-components within the sled must comply with applicable ORv2 specifications for IT payloads, and the Flatbed SLED Thermal Design Requirements.

6.3 PCB Stack-Up

Flatbed IT Gear Payload PCBAs and other adaptor PCBAs (such as the Tractor PCBA) may use any stackup which supports the high-level requirements, including electrical performance, safety, and compliance. *Note that ORv2 Specification Section 6.5, 48V IT Tray Power Specification, refers to PCB spacing rules applicable to safety and compliance on the Tractor PCBA.*

7. Tractor PCBA Control and Status Sub-System

7.1 Comms I2C Interface

The Payload BMC may utilize the Tractor PCBA as a resource for monitoring and controlling the Flatbed sled power consumption and thermal operating point. To present a relatively consistent and uniform hardware abstraction to BMC firmware across multiple payloads and sled designs, the Tractor PCBA has a single control and status interface connection through a cabled I2C link to the Payload BMC. This link is subsequently referred to as the “Comms” interface.

This I2C link is fanned out to the various Tractor PCBA resources through a multiplexing scheme. Either a discrete I2C multiplexer chip or a small uC-based interface may be used to implement the fanout from the Tractor PCBA Comms interface connector to the various I2C resources on the Tractor PCBA (power monitors, fan controllers, etc).

Tractor PCBA interrupt aggregation via a single I2C expander is recommended to decrease interrupt handling latency, if interrupts (SMBus ALERT) are implemented.

The Comms connector shall provide a reset pin, dedicated to any I2C-controlled multiplexers to assist in recovery from potential stuck-bus failures. This reset pin shall be pulled to a non-asserted state on the Tractor PCBA. The Flatbed Payload BMC may control this optional reset via a spare BMC GPIO pin if available.

Some Tractor PCBA designs may have high capacitive loading on the I2C buses. Tractor shall use I2C multiplexers (TCA9548A or equivalent) or repeaters (LTC4300A-1, ADUM1250, or equivalent) if necessary to ensure:

- The combined capacitive loading with the with the expected Comms cable assembly is less than the I2C bus specification of 400pF
- The maximum transaction speed is at least 100KHz

In addition, isolation and buffering of I2C buses simplifies "black boxing" of diverse Payload I2C master-side bus loading and pullup strengths, may improve I2C timing for large bus segments with many loads, and can improve slew rate management & signal integrity of falling edges of signals routed across cabled module interfaces.

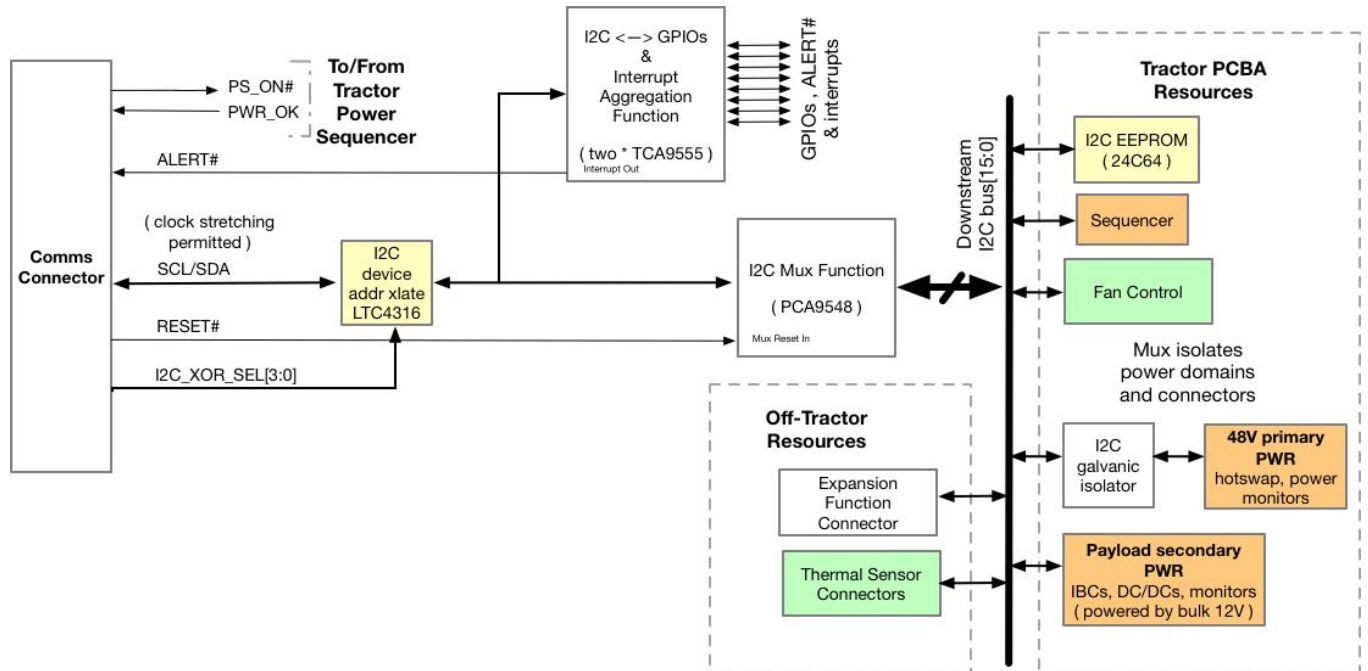

Figure 4: Recommended Tractor PCBA Control and Status Implementation

7.2 I2C Device Address Translation

The Tractor PCBA may experience I2C bus device address conflicts with accessible (ie., connectorized) I2C buses on the Payload BMC. It is recommended to provide an option for I2C device address translation immediately downstream of the Comms connector.

7.3 Comms Connector and Cable

The Comms interface cable is expected to be up to approximately 30" in length.

A shielded 24AWG cable bundle is recommended; this should result in a capacitive loading of approximately 15pF/foot. The I2C signals shall be shielded, with the shield drain connected to the Payload GND. Other signals may be included within the same shield, if they are predominantly static during I2C transactions (PWR_ON#, PS_OK, etc).

The Tractor PCBA will have a 14-pin 3.00mm pitch MicroFit Wire-to-Board Header (Molex 43045-1413, or equivalent) connector.

Pin #	Signal	Notes
1	SDA	To/from payload BMC
2	SCL	To/from payload BMC
3	GND	For harness to payload BMC SMBus header
4	ALERT#	To payload BMC
5	PS_ON#	ATX/EPS12V emulation (weak pullup to P3V3_STBY on Tractor), input

6	PWR_OK	ATX/EPS12V emulation, output
7	GND	For harness to payload power control header (if separate)
8	RESET#	Strong pullup on Tractor to P3V3_STBY. Resets Tractor PCBA I2C muxes and/or Tractor uC. May be driven by a payload BMC GPIO/Spare signal if available.
9	GND	For RESET# signal, in harness to appropriate payload header.
10	P3V3_STBY	
11..14	I2C_XOR_SEL[3:0]	Selectively short to P3V3_STBY in harness, controls Tractor PCBA I2C address XOR translation for a given Flatbed Payload. Use a wire AWG smaller (by #4) than max allowed in connector crimp to allow multiple wires to be crimped to a single GND (pin 9).



7.4 Programmable Devices and Configuration EEPROM

The Tractor PCBA shall include a reprogrammable EEPROM (24C04 or equivalent) to be used for recording system configuration information.

This EEPROM should be capable of containing FRU information as described in the [IPMI Platform Management FRU Information Storage Definition, V1.0 Rev 1.3](#). Note that Flatbed payload PCBAs may also contain a similar FRU EEPROM; the Tractor PCBA EEPROM is intended to contain:

1. FRU information specific to the Tractor PCBA
2. (Optional) FRU information for the Flatbed sled if the payload does not contain a suitable FRU EEPROM

Given that the Tractor PCBA FRU is a DC-input module, some IPMI fields may not be applicable. Tractor can support various different sled-level fan configurations, so the initial programming of the PCBA FRU EEPROM is not required to reflect final sled-level assembly configuration.

As per the ORv2 sled firmware management requirements, any Tractor PCBA programmable or field-configurable devices must be reprogrammable via the I2C interface, with the hardware hooks to implement a backup/verify/fallback scheme for firmware upgrades.

8. Tractor PCBA Power Path

8.1 Tractor Power Requirements

8.1.1 Inputs

The Tractor PCBA shall support all electrical requirements listed in the ORv2 48V IT Tray Power Specification. In particular, it must include the following details:

Tractor shall include input fusing and an input hotswap/softstart circuit capable of providing safe live insertion and extraction.

This input stage must comply to the electrical requirements detailed in the ORv2 48V IT Tray Power Specification (in particular section 6.16), under the following test conditions:

8.1.1.1 Operating Voltage Ranges

OVLO, UVLO, and hysteresis will be tested on the bench with a variable power supply driving the input, at output loadings of 0%, 50%, and 100% maximum rated power.

8.1.1.2 Noise Immunity

The hotswap circuit must not falsely trigger and shutdown or glitch sled power, reset, or other status signals due to noise sensitivity during adjacent sled or adjacent shelf operations (sled insertion, extraction, or fault).

- For full-width sleds that occupy the entire horizontal IT shelf, testing shall be performed with a single aggressor sled and a single victim sled.
- For partial-width sleds, testing shall be performed with a single aggressor sled and a single victim sled, in all possible location combinations on a single horizontal IT shelf.
- In both above cases, the horizontal IT shelf(s) shall be located in the furthest location(s) in the end user specified ORv2 rack from the rectifier shelf and UPS. If multiple shelf(s) are used, they shall be located adjacent to one another in the vertical direction.
- The victim and aggressor sleds are to be cabled, from additional rack components (switches, etc) to all ports with typical cables.
- The victim sled is to be operating normally.
- The aggressor sled is inserted, extracted, and faulted (causing a fuse or hotswap power interruption).

In accordance with the ORv2 48V IT Tray Power Specification, the aggressor sled shall not produce transients exceeding 40V ringing amplitude, 20nS ringing period. It is highly recommended that the hotswap turn-on current profile of the aggressor sled should not produce turn-on voltage sag on the horizontal IT shelf busbar greater than 5V.

The vendor shall provide a list of other Flatbed tray/payload combinations tested for interoperability (including rack & shelf positions tested), and the end user shall agree to the list of combinations.

8.1.1.3 TVS Clamping

The TVS function compliance may be verified by examination of schematic, BOM, and PCB layout.

8.1.1.4 Shortpin Function, Safe Removal

This function may be verified by use of a DMM during partial vs. full sled insertion into the horizontal IT Gear Shelf. Note that the ORv2 Appendix C details the mechanical dimensions of the busbar and connector.

8.1.1.5 Input Fusing

The Flatbed Tray-level input fusing must provide an interrupt capability equal to the maximum available rack busbar current of the plus a safety margin specified by the end user. This current level is set by the chosen rectifier and UPS shelf capacity, and must be evaluated in the worst-case (nearby/adjacent) IT shelf and Flatbed tray connector location, limited by the instantaneous resistance of the power sources, and source + load shelf busbars and clips.

Testing and validation may be performed using a combination of design calculations and lab measurements.

8.1.2 Outputs

The Tractor PCBA output voltages should conform to relevant specifications in the industry-standard ATX and EPS12V power supply specifications, including sequencing order, turn-on/off and ramp times, noise, transient performance, and overshoot. A 12V-only Tractor PCBA will comply with 12V output specifications. These published industry-standard specifications include test conditions. Because these power supply specifications cover multiple power levels, supported output voltages and maximum output current and power ratings for a particular Tractor design shall be specified by the end user.

8.1.3 Monitoring

The sled-level input 48V power bus shall include monitoring and telemetry capability via the Tractor Comms interface:

- Voltage accuracy of better than 1.5% at highest rated input voltage (59.5V)
- Current accuracy of better than 2.5% at full rated load
- Derived power measurements shall have an accuracy of better than 3.5% at full rated load
- Sample rates of up to at least 10 samples/second shall be supported.
- Resolution at highest rated levels greater than 9 bits (requires a 10 bit or higher ADC)

Each Tractor PCBA power output to the payload should include monitoring and telemetry capability via the Comms interface:

- Voltage accuracy of better than 2.5% at full rated load
- Current measurement is optional, accuracy of better than 2.5% at full rated load is recommended
- Sample rates of up to at least 10 samples/second shall be supported.
- Resolution at highest rated levels greater than 9 bits (requires a 10 bit or higher ADC)

8.1.4 ON/OFF Sequencing Control

The ORv2 48V IT Tray Power Specification details power on/off and restart in several sections including:

- Section 6.11, On/Off Control
- Section 16.6.2, Restart Function

The Tractor PCBA shall support these requirements for power cycle commands/functionality under software control via three alternative paths:

- The ATX-style PS_ON# signal from the payload BMC to the Tractor sequencer
 - Main Payload supplies can be held ON or OFF
 - STANDBY power supplies remain energized
- An I2C command interface from the payload BMC to the Tractor sequencer
 - Main Payload supplies can be held ON or OFF
 - STANDBY power supplies remain energized
- A monostable one-shot function driven via I2C access from the payload BMC to the Tractor PCBA, which then in turn cycles 54V power via the input hotswap circuit
 - Main Payload and STANDBY power supplies turn off, then on again
 - Follows the same sequencing as a cold-start of the rack

The Tractor PCBA shall provide a PWR_OK signal on the Comms connector (driven high to the Tractor 3.3V_STBY supply) indicating all payload supplies are ON and operating within design limits.

9. Tractor PCBA Fan Power and Control

For Flatbed implementations using thermal control schemes “Tractor-Master” and “BMC-Tractor”, the following functional requirements apply to the Tractor PCBA (see [SLED Thermal Design Requirements, Control Loop Schemes](#)):

The Tractor PCBA shall provide independent fan connectors, independent fused power, independent PWM control, and independent Tachometer status for each IT Flatbed sled fan. The number of fans per sled will vary depending on application; provisions for as many as twelve independent fans are recommended for very high power ORv2 tray designs. The fan connectors shall offer a retention feature or positive latch.

The Tractor PCBA shall provide a local RPM control loop for the fans. The Payload BMC may issue RPM control commands to Tractor over the Comms I2C interface.

- Fan PWM signal input duty cycle error shall be less than 5% when measured at an operating fan connector at a 22.5KHz nominal PWM frequency.
- Fan Tach signal monitoring accuracy shall be within 5%.

Support for 48V fans is strongly encouraged on high-power IT sled designs. A PWM holdoff path which clamps all fan PWM signals to 0% duty cycle during the Tractor power train on-sequencing period is recommended. Non-volatile storage of powerup default fan PWM settings is optional, but desirable.

The Tractor PCBA shall provide appropriate fusing upstream of the power pin(s) of each fan connector. A typical example for a 12V fan would be a 3A to 5A fast-blow fuse.

10. Tractor PCBA Thermal Sensing Support

For Flatbed implementations using thermal control schemes “Tractor-Master” and “BMC-Tractor”, the Tractor PCBA must provide thermal sensor functionality (see [SLED Thermal Design Requirements, Control Loop Schemes](#)). Tractor may provide or support a variety of sensors, including local or remote BJTs (2N3906, etc.), I2C, and 1-wire. The end user must specify the type of thermal sensing required.

IF Tractor supports remote I2C sensing (typical for “BMC-Tractor” applications), then the following I2C sensor support requirements apply as a minimum feature set:

The Tractor PCBA shall provide connectors for at least four independent I2C interface thermal sensor modules. The connectors must offer a retention feature. A recommended connector is the Molex 22-11-2052. Each connector shall provide:



Signal	Pin Number	Notes
P3V3_STBY	1	Same supply as used by Tractor PCBA Control/Status block, up to 10mA
SCL	4	10K pullup to P3V3_STBY
SDA	2	10K pullup to P3V3_STBY
GND	3	
ADDR0	5	(OPTIONAL) Resistor stuffing options to tie to one of {GND, P3V3_STBY, SCL, SDA}, allows up to 4 thermal sensors per Tractor PCBA SMBus branch.

11. Tractor PCBA Expansion Connector

Tractor will provide a single expansion connector PCB footprint. This footprint will accommodate a variety of connector types (board-to-board, ribbon, wire-to-board) and be a composite footprint. The PCBA footprint will be a standard plated thru-hole 10pin 25-mil square post vertical 100mil pitch double-row header. Example stuffing options include:

- A. Tyco Connectivity 5499910-1 (shrouded + keying, ejector latches)
- B. Molex 90130-1210 (shrouded + keying, no latches)
- C. Samtec HW-TH series (board-to-board stacker options in various heights)

Clearance areas (no routes, no components) must be provided at the ends of each connector adequate for:

- Locking cable retention latches, approximately 300 mils past the ends of the pinfield
- 6-32 hex machined metal standoffs to a PCBA mezzanine mating with the tractor expansion connector(s)

Overlapping footprints are suggested for this area, as pictured below. **Please note that the pinout shown has pin 1 in the upper-left corner, similar to the standard ribbon cable pinout (Tyco 5499910-1). The pin 2 of the Molex 90130-1210 connector instance on the schematic must connect to pin 1 of the the Tyco 5499910-1 connector instance.**

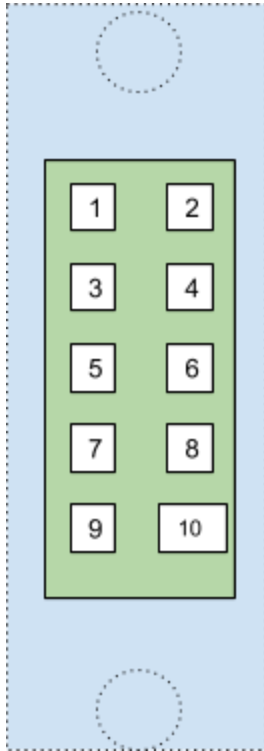

Tyco Pin Number	Molex Pin Number	Signalname	Notes
1	2	P3V3_EXPANSION	Provide a stuffing option to use P3V3 (fused) or P3V3_STBY
2	1	P3V3_EXPANSION	Provide a stuffing option to use P3V3 (fused) or P3V3_STBY
3	4	EXP_SMB_SDA	
4	3	GND	
5	6	GND	
6	5	EXP_SMB_SCL	
7	8	GND	Second function: USB shield/GND
8	7	EXP_GPIO1_RSVD	Reserved for Future Use (RFU)

9	10	EXP_GPIO2_RSVD	RFU, second function: USB-
10	9	EXP_GPIO3_RSVD	RFU, second function: USB+

12. SLED Documentation Requirements

The vendor shall provide reproducible copies of all pertinent documentation relating to the following:

Product Information

- Bill of Materials
- Schematics
- Functional test report

Final Compliance Approval

- NRTL certificate and report, Conditions of Acceptability and test report
- CB Certificate and report, including schematics
- Manufacturer's Declaration of Conformity to EN 60950-1
- FCC Part 15 Class A and CISPR 22 Class A test data
- Declaration of Conformity to EN 61000-3-2 Class A and test report including waveforms and harmonic output levels
- BSMI Certificate, when appropriate

13. SLED Environmental Requirements

Each sled-level integrated Flatbed design must comply with the environmental requirements outlined in the ORv2 Specification section A.5 (48V Rectifier Specification with Single Phase AC Input), with the exception of section A.5.4 (Acoustic Noise) to ensure similar shipping and storage conditions may be applied to 48V rack components.

14. SLED Regulatory Compliance

Each sled-level integrated Flatbed design must comply with the requirements outlined in Appendix A, Flatbed Standards Compliance, with the following clarifications:

- For the purposes of Emissions and Immunity, the Flatbed Sled is a DC-powered DUT.
- When a sled **without** a payload is being tested for compliance, the testing scenarios shall include:
 - A single sled installed in the worst-case position in an ORv2-compliant rack specified by the end user (tray location TBD by the test laboratory for the rack/sled combination)
 - Compliance shall be measured at output load levels of 0%, 50%, and 100% applied to all output supplies simultaneously, preferably using resistors included in the sled in place of the payload. The use of active loads for testing is also acceptable.
- When a sled **with** a payload is being tested for compliance, the testing scenarios shall include:
 - A single sled installed in the worst-case position in an ORv2-compliant rack specified by the end user (tray location TBD by the test laboratory for the rack/sled combination)
 - Compliance shall be measured when the sled is operating under typical load conditions and with all ports fully loaded

15. SLED Reliability and Quality

Each sled-level integrated Flatbed design must comply with the requirements outlined in Appendix B, Flatbed Quality and Reliability, with the following clarifications:

- (no additional clarifications)
-

16. Flatbed PAYLOAD Specification Requirements

The following requirements listed for the Flatbed Payload (IT Gear, such as a server motherboard) are intended as **guidelines** to describe fully Flatbed-compliant Payloads. Full compliance ensures effective integration into sled, rack, and datacenter-level environments. Flatbed sleds may be integrated using non-compliant payloads at the discretion of the end user.

16.1 Power Inputs

The Payload shall be capable of being powered by one of the following two options:

- ATX or EPS12V specification-compliant
 - +12V/+5V/+3.3V/+5V_STBY
 - Up to 950W total
 - Industry-standard sequencing and control/status (PS_ON#, PWR_OK)
- 12V + 12V_STBY
 - One or two separate 12V domains (12V_1, 12V_2)
 - Up to 2000W per domain
 - Up to 4A on 12V_STBY
 - Main 12V power drain must be <25A until PWR_OK assertion (asserts within 250mS after 12V initially rises above 10V)

16.2 I2C/SMBus Requirements

Any I2C or SMBus buses accessible on Payload PCBA connectors shall operate at 3.3V levels, including local pullups and any local active pullup devices or I2C bus multiplexers.

These buses include PCIe connector SMBus, as well as other connectors for power supply PMBus communication and miscellaneous expansion boards (such as the Flatbed Tractor PCBA).

16.2.1 Address Space on Expansion Connectors

The I2C address space on all connector-accessible buses must be “clean”, having no devices other than a master and optionally an I2C multiplexer to isolate other devices addressed by the same master. See the illustrations below for examples:

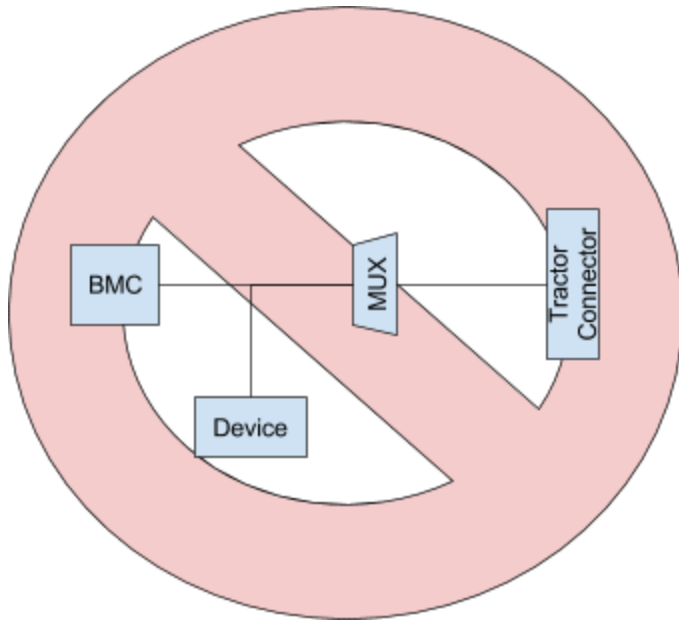

Figure 5: Example of bad I2C configuration with “unclean” address space

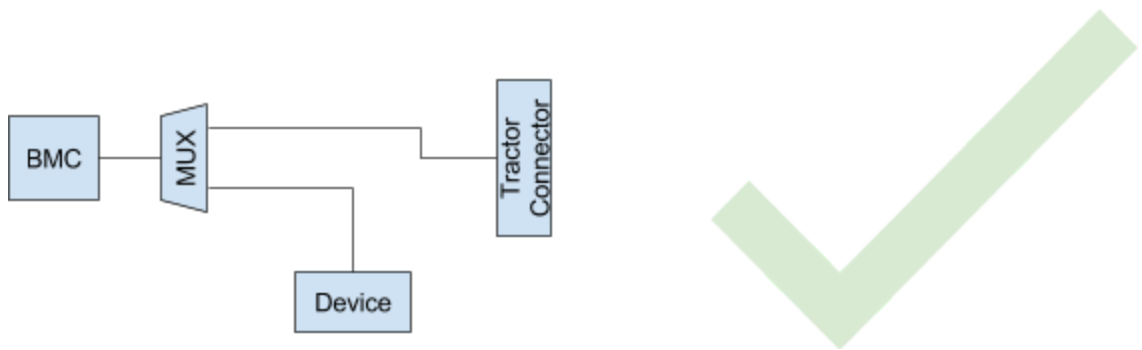

Figure 6: Example of good I2C with “clean” address spaces

This guideline includes each PCIe and expansion slot, which must have a clean I2C address space. This can be accomplished with MUXes or switches as shown above. No addressable devices other than an I2C MUX with one of the addresses listed below may be present on the bus.

16.2.2 I2C Multiplexer Usage

The following 7-bit addresses may be used for MUXes on the motherboard:

- 0x71
- 0x74
- 0x75
- 0x77

Note: I2C addresses shown are all 7-bit. For example, address 0x75 is:

A6	A5	A4	A3	A2	A1	A0	RW
----	----	----	----	----	----	----	----

1	1	1	0	1	0	1	X
---	---	---	---	---	---	---	---

All I2C MUXes and/or switches must be soft disable-able, or must have a NULL switch port (no outputs enabled) which can be activated when the MUX is not active.

There may be no more than one in-band addressable MUX before each connector.

It is recommended to avoid the use of any discrete I2C MUXes and use separate master controllers on each Payload I2C bus routed to an accessible connector.

16.3 BMC

NOTE: This section applies IF the Payload includes a BMC. IF there is no BMC, this section may be removed from the Payload requirements.

The BMC must be able to boot Linux. *Note: OpenBMC is intended as the primary software baseline for Flatbed sled-level control. Support of OpenBMC is strongly recommended.*

The Payload shall support BMC image updates via one or more of the below methods:

- Update via REST API
- Update via physical replacement of BMC/ROM device.

The BMC shall be capable of updating the Payload BIOS image.

16.3.1 BMC NC-SI

The Payload shall have a 100Base-TX RJ45 connector suitable for NC-SI use by the BMC.

16.3.2 BMC I²C

The Payload must provide a header with an I2C bus and GND/shield for communication with the Flatbed Tractor PCBA. This I2C bus should have pullups to the same Payload 3.3V power supply used by other BMC I/O.

The BMC I2C master must have I2C specification-compliant drivers (slew rate limited) and receivers (glitch rejecting).

This I2C port must be connected to the BMC, and it must have a “clean” address space as described in the general [I2C/SMBus Requirements](#).

No addressable devices other than an I2C MUX with one of the allowed addresses listed may be present on the bus when communicating with Tractor. Other downstream devices may be accessed by the same master as long as they are behind different MUX ports.

See the general [I2C/SMBus Requirements](#) section for additional BMC I2C bus requirements.

16.4 Timebase Accuracy

The Payload should be capable of creating timestamps with short-term accuracy equal to or better than 1.5ppm over the full operating temperature range of the Flatbed sled assembly.

A Payload PCB schematic and layout that provides an appropriate TCXO footprint as an alternative clock oscillator stuffing is recommended.

The following devices must receive a clock of this accuracy level:

- CPU(s)
- For Intel server architectures: PCH

16.5 PCIe Slots

The Payload PCIe slots should support standard pin usage where possible, including RSVD pin usage.

Re-purposed use of the RSVD pins outside of industry standards or pending standards is generally discouraged (examples may include link/lane splitting, USB). An example of a widely accepted RSVD pin re-mapping is the PROCHOT and PRWBRK# functions.

Additional mechanical requirements on PCIe slots are listed in the [Mechanicals](#) section.

16.6 BIOS

The current definition of Flatbed is independent of BIOS implementation details.

16.7 Mechanicals

Airflow

- Front to back
- DIMMs, PCIe cards, heatsink fins long edges shall all be oriented in the same direction, along the airflow direction.

Dimensions

- Height agnostic. Minimum height is 1 Open Rack Unit (ORU).
- Max width 495.3mm (19.5")
- Max depth depends on Rack depth
 - Max depth 404mm suggested for shallow ORv2 applications
 - Max depth 544mm suggested for deep ORv2 applications
- Backside component maximum height 10mm (394 mils) is recommended
- PCBA thickness
 - 62 mils to 120 mils nominal thickness
 - no more than +/-15% maximum deviation from nominal specified thickness

Preferred Layouts

- PCIe Slots
 - PCIe at the "front" edge of PCBA, facing the cold aisle.
 - Pitch of PCIe cards no closer than standard spacing
 - Preferred pitch of leftmost and rightmost PCIe slots is 1.5x standard or larger to support tall card heatsinks
- CPU socket attachment points & details on the PCB should follow the CPU vendor reference design(s) closely to ease the re-use of standard heat sink components
- Power input connector(s) preferred location is at rear for shortest cable length to Tractor PCBA
- Comms connector for SMBus (to Tractor PCBA) should be located within a 24" manhattan route distance from the "left rear" corner of the Payload PCBA when seen from the cold aisle, as defined by the front-to-rear airflow direction constraint.

- User connectors and I/O such as LEDs, pushbuttons (reset, etc.)
 - Preferred on same edge as PCIe (front edge, cold aisle, air intake)
 - Location is at a much lower priority than PCIe (e.g. do not move PCIe slots to rear to make room for USB at front edge)
 - If user I/O is not located at “front” edge, connectorization which supports cables to separately mounted front edge I/O cards is recommended.

16.8 Thermals

The Payload shall include local temperature sensing of critical die and/or component temperatures, accessible by the BMC. **IF there is no BMC on the Payload**, some method of support for remote monitoring or telemetry of critical component temperatures should be provided.

16.9 Standards Compliance

Each Flatbed Payload design must comply with the requirements outlined in Appendix A, Flatbed Standards Compliance, with the following clarifications:

- For the purposes of EMC Emissions and Immunity, the Flatbed Payload is a component of the Flatbed **SLED** top-level assembly, and compliance testing must be performed when integrated into the chosen sled implementation. The Flatbed **SLED** for a given payload must include any shielding and/or filtering to ensure compliance to the [SLED Regulatory Compliance](#) specification.

16.10 Quality and Reliability

Each Flatbed Payload design must comply with the requirements outlined in Appendix B, Flatbed Quality and Reliability, with the following clarifications:

- (no additional clarifications)

Appendix A: Flatbed Standards Compliance

Materials

The all PCBAs shall be RoHS-6 compliant.

Basic Compliance Requirements

Safety

The equipment shall be designed to comply with the latest edition, revision, and amendment of the following standards. The equipment shall be designed such that the end user could obtain the safety certifications.

- UL/CSA/IEC/EN 60950-1
- UL/CSA/IEC/EN 62368-1

See the ORv2 Specification, 48V IT Tray Power Specification, Safety Standards section for more detailed descriptions of the safety requirements.

EMC

The equipment must meet the following *general* requirements when operating under operating and measurement conditions defined in the previous *individual* subcomponent EMC compliance specification requirements:

Emissions

6dB margin from the FCC Class A limit is required for all emission test, both radiated emission and conducted emission. When the EUT is DC powered, a DC line conducted emission test is required.

Primary EMC Standards apply to emission test include, but not limited to

- FCC Part 15, Subpart B
- EN 55022: 2010 / CISPR 22: 2008 (Modified)
- EN 55032: 2012 / CISPR 32: 2012 (Modified) - Effective 05/03/2017
- EN61000-3-2: 2006/A1 : 2009/A2 : 2009
- EN61000-3-3: 2008

For DC power related testing, when applicable GR 1089 / GR 3160 may be referenced.

Immunity

Primary EMC Standards apply to immunity test include, but not limited to

- EN 55024: 2010 / CISPR 24: 2010 (Modified)
- CISPR 35: 2014 (current publication: CISPR/I/463/FDIS 2013-12)

Each individual basic standard for immunity test has its specific passing requirement as illustrated below. When the EUT is DC powered, immunity testing involves a disturbance applied to power line apply to the DC input power.

- EN61000-4-2 Electrostatic Discharge Immunity (6kV contact, 8kV air)
- EN61000-4-3 Radiated Immunity [$> 10V/m$]
- EN61000-4-4 Electrical Fast Transient Immunity (1kV power (AC), 0.5kV signal)
- EN61000-4-5 Surge AC Port (2kV CM, 1kV DM)
- EN61000-4-5 Surge Signal Port (2KV CM, 1KVDM)
- EN61000-4-5 Surge DC Port (0.5kVCM, 0.5KVDM)
- EN61000-4-6 Immunity to Conducted Disturbances [$> 10V rms$]
- EN61000-4-8 Power Frequency Magnetic Field Immunity (30A/m), when applicable
- EN61000-4-11 Voltage Dips, Short Interruptions, and Voltage Variations

For DC power related testing, when applicable GR 1089 / GR 3160 may be referenced.

Country Specific EMC Requirements

Most countries / region have country specific / regional EMC requirements. In addition to above listed EMC standards, the equipments shall demonstrate compliance to standards which includes, but not limited to

- CNS 13438: 2006
- AS/NZS CISPR22: 2009/A1:2010
- Industry Canada ICES-003
- VCCI V-3/2013-04
- KN 32/ KN 35
- ANATEL Resolution 242 / 323 / 442

General Compliance

Please note that “Products with the CE marking indicate compliance with the 2014/35/EU and 2014/30/EU directives which include the Safety and EMC standards listed.”

Unless otherwise noted, compliance is to the latest version of the standards listed above.

The equipment shall be designed and NRTL-C/CB certified to comply with the most current version of the standards specified above. The preferred safety agencies are CSA, UL, TUV and VDE. Please consult with the client for approval if it is desired to use a safety agency other than the customer’s preferred safety agencies. These requirements may change throughout the life of the product, and upon request by the client, the vendor shall obtain additional certifications for any other standards.

EMC Laboratory shall meet the basic accreditation requirement by A2LA or NvLAP. In addition, to obtain FCC, the EMC laboratory selected shall reside in the country which maintain MOU with FCC. The end user retains the right to audit any EMC laboratory selected by vendor. The selection of EMC laboratory shall be approved by the end user.

When in-country testing is required, it is important for vendor to ensure confidentiality of the product when sent for in country testing. Proper NDA shall be developed between vendor and the selected test laboratory listed by the respective regulatory agency.

Product Compliance Requirements

The equipment shall be designed and certified to comply with national standards and regulations. Below is the list of specific countries requiring product certification.

- US/Canada (NRTL/C, FCC/IC)
- EU (CE)
- International (CB Scheme)

From time to time the countries shown below (not exclusive) may be added to the list with the understanding that the certifications needed and their priority will be determined on a case by case basis.

- Taiwan (BSMI)
- Japan (VCCI)
- Australia/New Zealand (RCM)
- Brazil (Anatel)
- India (BIS)
- Korea (KC)
- South Africa (NRCS LoA)
- Saudi Arabia (CITC)

Appendix B: Flatbed Quality and Reliability

The following requirements are broadly similar to other Open Compute product specifications; however, some restrictions are tailored to better match the design intent of Flatbed to serve as a solution for adapting Off-The-Shelf server designs with multiple end user and diverse sub-assembly sourcing.

1. Specification Compliance

Vendors must ensure that PCBAs meet these specifications as a stand-alone unit and while functioning in a complete server system. The vendor is ultimately responsible for assuring that the production PCBAs conform to this Specification with no deviations. The Vendor shall exceed the quality standards demonstrated during the pilot build (PVT) while the PCBA is in mass production. Customer must be notified if any changes are made which may impact product quality.

2. Labels and Markings

Subassembly Types	Label Description	Label Type	Barcode Req'd?
PCBA, Cables	Vendor P/N, S/N, REV	adhesive label	yes
PCBA	Vendor Logo, Name & Country of Origin	silkscreen	no
PCB	Vendor P/N, REV	TOP copper etch or silkscreen	no
PCB	Vendor Logo, Name	silkscreen	no
All	Purchaser P/N	adhesive label	yes
All	Date Code (Industry Standard: WEEK / YEAR)	adhesive label	yes
PCBA	RoHS compliance	adhesive label	no
PCBA	WEEE symbol: All PCBAs will have the crossed out wheeled bin symbol to indicate that it will be taken back by the Manufacturer for recycle at the end of its useful life. This is defined in the European Union Directive 2002/96/EC of January 27, 2003 on Waste Electrical and Electronic Equipment (WEEE) and any subsequent amendments.	silkscreen	no
PCBA	CE Marking	silkscreen	no
PCBA	UL Marking	silkscreen	no
All Applicable	MAC Address. One per network interface. Applied to the PCBA which contains the device with the MAC.	adhesive label	yes
All Applicable	Asset Tag (if required by purchaser / end user)	adhesive label	yes
PCBA	Ports, Connectors, Memory slots	silkscreen	no

16.11 Change Orders

Vendors must notify customer any time a change is made to PCBAs. A Specification Compliance Matrix will be submitted to customer for each revision of the PCBAs, including prototype samples.

16.12 Failure Analysis

Vendors shall perform failure analysis on defective units which are returned to the vendor. Feedback shall be provided to the customer (and end user, if not the same party) with a Corrective Action plan within two weeks from the date which the units were received at the Vendor's Facility.

16.13 Warranty

The Vendor shall warrant all PCBAs against defects and workmanship for a period of two years from the date of initial deployment at customer's facility. The warranty is fully transferable to any end user.

16.14 MTBF Requirements

All PCBAs shall have a minimum Service Life of 5 years (24 Hours / day, Full Load, at 45C ambient temperature).

Vendors shall provide a calculated MTBF number based on expected component life.

16.15 Control Change Authorization and Revision Control

All changes beginning with the pilot run must go through a formal ECO process. The revision number (on the PCBA label) will increment accordingly.

Revision Control: copies of all ECOs affecting the product will be provided to customer for review and approval. Adequate notification of any changes must be provided to prevent production flow disruptions.

16.16 PCB Tests

Server ODMs should arrange Independent 3rd party lab testing of SET2DIL, IST, and IPC- 6012C for each motherboard, riser card and mid-plane PCB from every PCB vendors. Midplanes and other PCBAs (such as Tractor) without high speed differential signals do not require SET2DIL testing.

Results of all testing performed shall be available for review by the end user.

16.17 Secondary Components

It is recommended that PCB fabrication is planned with 3 vendors at EVT.

EVT and DVT build plans should cover all possible combinations of key components of DC to DC VRs, including output inductor(s), MOSFETs and drivers.

The ODM should provide 2nd sourcing plans and specification comparisons before each build stage.

16.18 Prescribed Materials

Disallowed Components

The following components are not used in the design of PCBAs:

- Components disallowed by the European Union's Restriction of Hazardous Substances Directive (RoHS 6)
- Trimmers and/or potentiometers
- Dip switches

Capacitors & Inductors

The following limitations apply to the use of capacitors and inductors:

- Only aluminum organic polymer capacitors made by high quality manufacturers are used; they must be rated 105°C
- All capacitors have a predicted life of at least 50,000 hours at 45°C inlet air temperature, under worst-case operating conditions
- Tantalum capacitors using manganese dioxide cathodes are forbidden
- SMT ceramic capacitors with case size > 1206 are forbidden (size 1206 are still allowed when installed far from the PCB edge and with a correct orientation that minimizes risks of cracks)
- Ceramic material for SMT capacitors must be X7R or better material (COG or NP0 type are used in critical portions of the design)
- SMT inductors are preferred. The use of through-hole inductors is discouraged, and allowable only when a suitable SMT alternative is not available.

Component De-rating

For transformers, inductors, capacitors, FETs, and diodes, a minimum 20% de-rating SHALL be used.

For resistors, a minimum 30% de-rating SHALL be used.

Revision History

Date	Revision	Modifications
2017-10-04	0.01	Draft release, initial copy
2017-10-13	0.03	Draft release <ul style="list-style-type: none"> • Incorporated feedback from OCP Rack&Power conference call
2017-11-02	0.04	Draft release to OCP for review before Incubation Committee <ul style="list-style-type: none"> • Added Revision History • Removed change highlights and strikethroughs from rev 0.03 • Changed Comms connector SPARE pin to P3V3_STBY for different XOR xlate encoding. XOR[3:0] floating = no translation. • Redefined Thermal Sensor ADDR0 pin for up to 4 possible addresses • Thru-hole inductors are changed from “disallowed” to “allowed only when SMT alternatives not available” • Removed separate Payload EMC compliance section, Payloads to be tested as part of integrated Sleds • Listed example components of Thermal “kits” • Thermal sensor connector ADDR0 pin function updated • Tractor-ATX block diagram updated, connectors = ATX & EPS12V • Comms connector SPARE pin changed to P3V3_STBY, XOR_SEL[] pin description changed
2017-11-14	0.05	Draft release, feedback from Rack&Power conference call, changes highlighted

		<ul style="list-style-type: none">• Test conditions for Sled/Shelf power interop testing added• Shortpin staging length recommendation added
--	--	---