



OPEN

Compute Project

Storage:
**Single port T-Card for storage
device with Ethernet interface**

Rev 2

Author: Alvin Cox, Seagate Technology LLC

Author: Asghar Riahi, Seagate Technology LLC

1 Scope

This specification defines the technical requirements and design of an adaptor card that allows a storage device with Ethernet interface to be connected to a gigabit network through a standard RJ-45 connector.

2 Contents

1	Scope	2
2	Contents	2
3	Overview.....	3
3.1	Description	3
3.2	License	3
4	Normative references.....	5
5	Definitions, symbols, abbreviations, keywords.....	5
5.1	Definitions	5
5.2	Symbols and abbreviations	5
5.3	Keywords	5
5.4	Editorial conventions.....	6
6	Mechanical characteristics	7
6.1	Device and network connectors.....	7
7	Electrical characteristics	12
7.1	Ethernet signals	12
7.2	Power	12
7.3	SFP transceiver	12
8	Example single port T-Card (Informative)	13
8.1	Schematic	13
8.2	Circuit board layout.....	14
8.3	Assembly Drawing	17
8.4	Bill of materials.....	18

3 Overview

3.1 Description

The single port T-Card is designed to adapt the connector on a storage device with Ethernet interface to 1000Base-T RJ-45. This is intended for use as a tool to aid in the development of systems using the storage device with an Ethernet interface. The second Ethernet port, P1, and I²C of the storage device with Ethernet Interface are not connected on this T-Card. Figure 1 illustrates an example single port T-Card.



Figure 1 Single port T-Card

3.2 License

As of December 20, 2013, the following persons or entities have made this Specification available under the Open Web Foundation Final Specification Agreement (OWFa 1.0), which is available at <http://www.openwebfoundation.org/legal/the-owf-1-0-agreements/owfa-1-0>:

Seagate Technology LLC

You can review the signed copies of the Open Web Foundation Agreement Version 1.0 for this Specification at <http://opencompute.org/licensing/>, which may also include additional parties to those listed above.

Your use of this Specification may be subject to other third party rights. THIS SPECIFICATION IS PROVIDED "AS IS." The contributors expressly disclaim any warranties (express, implied, or otherwise), including implied warranties of merchantability, non-infringement, fitness for a particular purpose, or title, related to the Specification. The entire risk as to implementing or otherwise using the Specification is assumed by the Specification implementer and user. IN NO EVENT WILL ANY PARTY BE LIABLE TO ANY OTHER PARTY FOR LOST PROFITS OR ANY FORM OF INDIRECT, SPECIAL, INCIDENTAL, OR CONSEQUENTIAL DAMAGES OF ANY CHARACTER FROM ANY CAUSES OF ACTION OF ANY KIND WITH RESPECT TO THIS SPECIFICATION OR ITS GOVERNING AGREEMENT, WHETHER BASED ON BREACH OF CONTRACT, TORT (INCLUDING NEGLIGENCE), OR OTHERWISE,



AND WHETHER OR NOT THE OTHER PARTY HAS BEEN ADVISED OF THE POSSIBILITY OF SUCH DAMAGE.

4 Normative references

Referenced standards and specifications contain provisions that, by reference in the text, constitute provisions of this specification.

INF-8074i, *SFP (Small Form Factor Pluggable) 1 Gb/s Transceiver*

TBD number, *Open Compute Project Storage: Storage device with Ethernet interface Serial-GMII Specification*

SFF-8482, *Serial Attachment 2X Unshielded Connector*

SFF-8680, *Serial Attachment 12 Gb/s 2X Unshielded Connector*

5 Definitions, symbols, abbreviations, keywords

5.1 Definitions

5.2 Symbols and abbreviations

Abbreviation	Meaning
I ² C	Inter-Integrated Circuit
LED	Light Emitting Diode
Mbps	Megabits per second
RX	receiver
SFP	Small Form-factor Pluggable
TX	transmitter
V	volts

5.3 Keywords

The key words "MUST", "MUST NOT", "REQUIRED", "SHALL", "SHALL NOT", "SHOULD", "SHOULD NOT", "RECOMMENDED", "MAY", and "OPTIONAL" in this document are to be interpreted as described in RFC 2119.

MAY This word, or the adjective "OPTIONAL", mean that an item is truly optional. One vendor may choose to include the item because a particular marketplace requires it or because the vendor feels that it enhances the product while another vendor may omit the same item. An implementation which does not include a particular option **MUST** be prepared to interoperate with another implementation which does include the option, though perhaps with reduced functionality. In the same vein an implementation which does include a particular option **MUST** be prepared to interoperate with another implementation which does not include the option (except, of course, for the feature the option provides.)

MUST This word, or the terms "REQUIRED" or "SHALL", mean that the definition is an absolute requirement of the specification.

MUST NOT This phrase, or the phrase "SHALL NOT", mean that the definition is an absolute prohibition of the specification.

SHOULD This word, or the adjective "RECOMMENDED", mean that there may exist valid reasons in particular circumstances to ignore a particular item, but the full implications must be understood and carefully weighed before choosing a different course.



SHOULD NOT This phrase, or the phrase "NOT RECOMMENDED" mean that there may exist valid reasons in particular circumstances when the particular behavior is acceptable or even useful, but the full implications should be understood and the case carefully weighed before implementing any behavior described with this label.

VENDOR SPECIFIC Something (e.g., a bit, field, code value) that is not defined by this specification and **MAY** be used differently in various implementations.

5.4 Editorial conventions

Certain words and terms used in this specification have a specific meaning beyond the normal English meaning. These words and terms are defined either in the glossary or in the text where they first appear.

Lists sequenced by lowercase or uppercase letters show no ordering relationship between the listed items.

Lists sequenced by numbers show an ordering relationship between the listed items.

If a conflict arises between text, tables, or figures, the order of precedence to resolve the conflicts is text; then tables; and finally figures. Not all tables or figures are fully described in the text. Tables show data format and values. Notes and examples do not constitute any requirements for implementers and notes are numbered consecutively throughout this specification.

6 Mechanical characteristics

6.1 Device and network connectors

6.1.1 T-Card storage device receptacle connector

The single port T-Card card uses a Backplane Fixed (Receptacle) connector defined in SFF-8482 and SFF-8680 to connect to a storage device with an Ethernet interface. The example single port T-Card in this specification uses straddle mount version of the Fixed (Receptacle) connector. Figure 2 illustrates the SFF-8482/SFF-8680 system Fixed (Receptacle) connector.

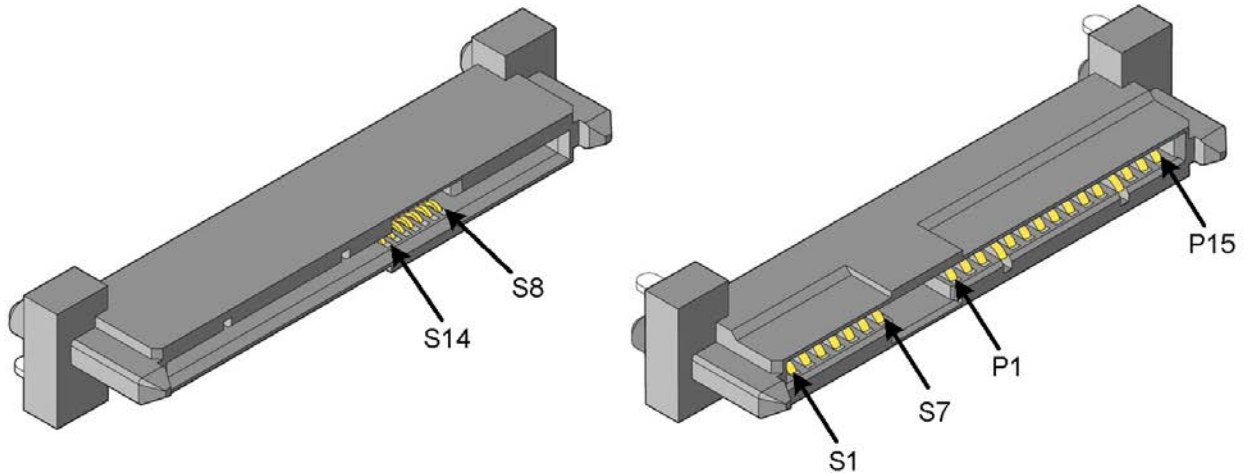

Figure 2 Fixed (Receptacle) connector

6.1.2 T-Card device connector pin assignment

The single port T-Card only provides one port of Ethernet and ties the signal on P11 to an LED. Table 1 defines the subset of storage device with Ethernet interface functionality that is utilized by this adaptor. See *Open Compute Project Storage: Storage device with Ethernet interface* for the device pin assignment.

Table 1 Single port T-Card device connector pin assignment

Segment	Pin	Adaptor receptacle
Signal	S1	GROUND
	S2	TX0+ ¹
	S3	TX0- ¹
	S4	GROUND
	S5	RX0- ¹
	S6	RX0+ ¹
	S7	GROUND
	S8	GROUND
	S9	N/C
	S10	N/C
	S11	GROUND
	S12	N/C
	S13	N/C
	S14	GROUND
Power	P1	N/C
	P2	N/C
	P3	N/C
	P4	GROUND
	P5	GROUND
	P6	GROUND
	P7	+5V PRECHARGE ²
	P8	+5V ²
	P9	+5V ²
	P10	GROUND
	P11	LED
	P12	GROUND
	P13	+12V PRECHARGE ²
	P14	+12V ²
	P15	+12V ²
Key:		
N/C = not connected		
1. See 7.1 for TX and RX electrical characteristics. 2. See 7.2 for power requirements.		

6.1.3 Power connector

Power is delivered to the single port T-Card by a surface mount, 4 pin, 3mm Micro-Fit connector illustrated in Figure 3. This connector is used to supply power to the attached storage device and a +3.3V regulator that supplies power to the SFP transceiver. The pin assignment is defined in Table 2. See 7.2 for power requirements.

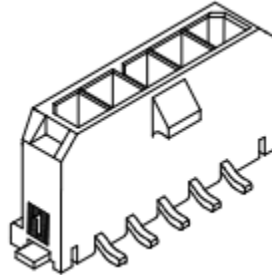

Figure 3 Micro-Fit power connector

Pin	Voltage
1	+12V
2	Ground
3	Ground
4	+5V

Table 2 Voltage connector pin assignment

6.1.4 T-Card SFP connector

The single port T-Card uses a standard SFP cage defined in INF-8074i for connecting a transceiver that provides a copper Ethernet interface. Figure 4 illustrates the SFP cage and Table 3 defines the signals pin assignment.

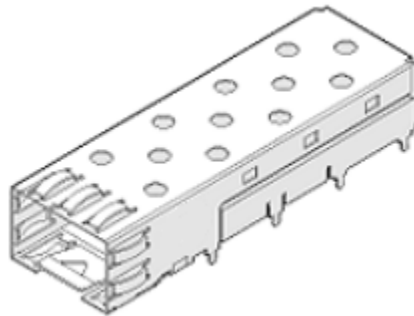

Figure 4 SFP Cage

Table 3 SFP cage pin assignment

Segment	Pin	T-Card receptacle	SFP module ¹
Bottom of Board	1	Ground	VeeT
	2	N/C	TxFault
	3	Ground	TxDisable
	4	Pull-up	MOD-DEF(2)
	5	Pull-up	MOD-DEF(1)
	6	Pull-up	MOD-DEF(0)
	7	N/C	RateSelect
	8	N/C	LOS
	9	Ground	VeeR
	10	Ground	VeeR
Top Of Board	11	Ground	VeeR
	12	RD0-	RD-
	13	RD0+	RD+
	14	Ground	VeeR
	15	+3.3V	VccR
	16	+3.3V	VccT
	17	Ground	VeeT
	18	TD0+	TD+
	19	TD0-	TD-
	20	Ground	VeeT
1. This column is for reference only. See INF-8074i.			

6.1.5 SFP transceiver attachment

The transceiver modules slides into the SFP cage when oriented as illustrated in Figure 5.



Figure 5 SFP module installation

To remove an installed module, pull down the latch on the module and carefully remove it. An example of the removal position is illustrated in Figure 6.



Figure 6 SFP module removal

6.1.6 T-Card attachment

The single port T-Card's device connector only mates to the device in one orientation. See Figure 7.



Figure 7 T-Card installed on device

7 Electrical characteristics

7.1 Ethernet signals

The TX and RX signals shall meet the requirements defined by the *Serial-GMII Specification*. This specification may be obtained at:

<ftp://ftp-eng.cisco.com/smii/sgmii.pdf>

7.2 Power

The single port T-Card requires either +5V or a combination of +5V and +12V depending on the requirements of the storage device it is used with. SFP transceivers operate at +3.3V, a regulated output generated from the +5V input. The specific power requirement is a combination of the power required to operate the SFP transceiver and the power for the Ethernet storage device. Refer to the product datasheets to determine the specific voltage and current requirements.

7.3 SFP transceiver

The SFP transceiver shall be a 1000 Mbps only module that conforms to the INF-8074i specification. Do not use Copper SPF 10/100/1000 Mbps modules that perform auto-negotiation. The single port T-Card does not have auto-negotiation capability. Example SFP transceivers are illustrated in Figure 8.



Figure 8 Example 1000Base-T SFP transceivers

8 Example single port T-Card (Informative)

8.1 Schematic

The schematic for an example single port T-Card is provided in Figure 9 and is also included in PDF format in the zip file available under this specification number.

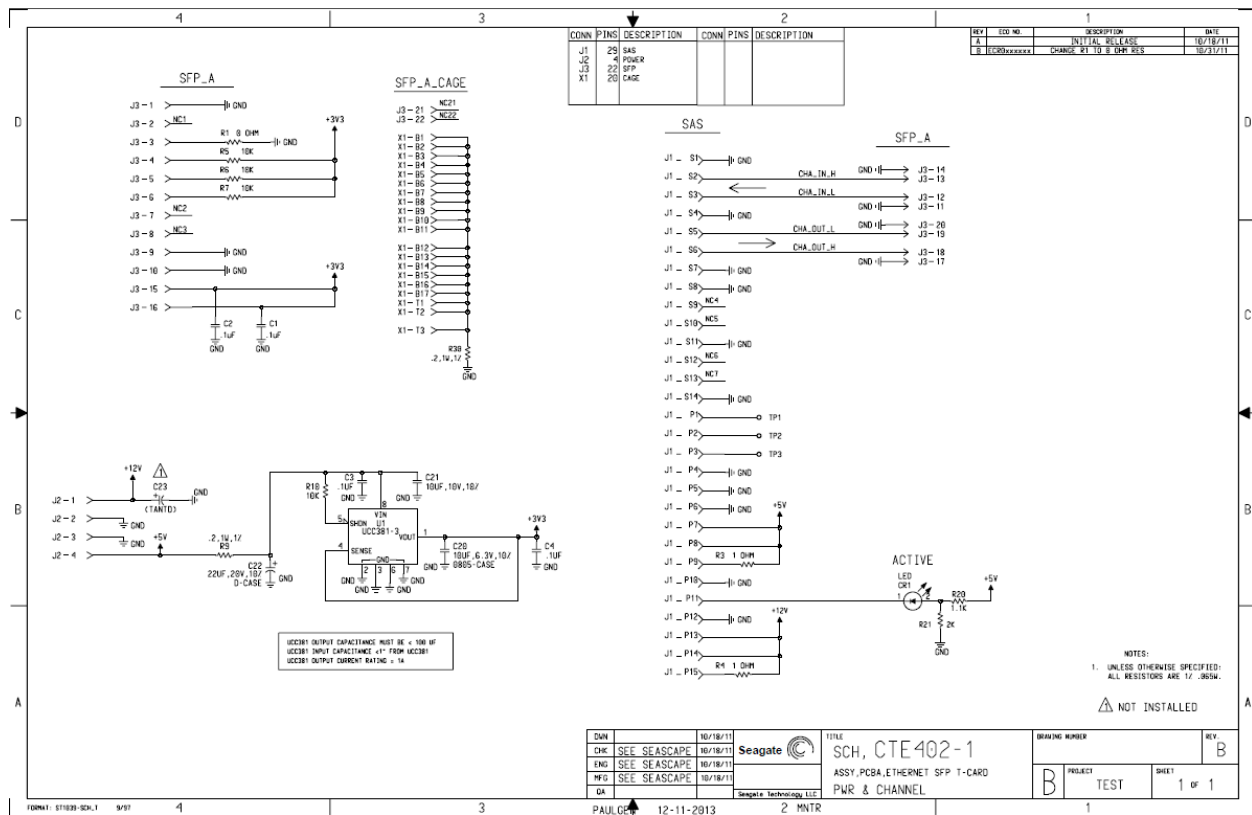
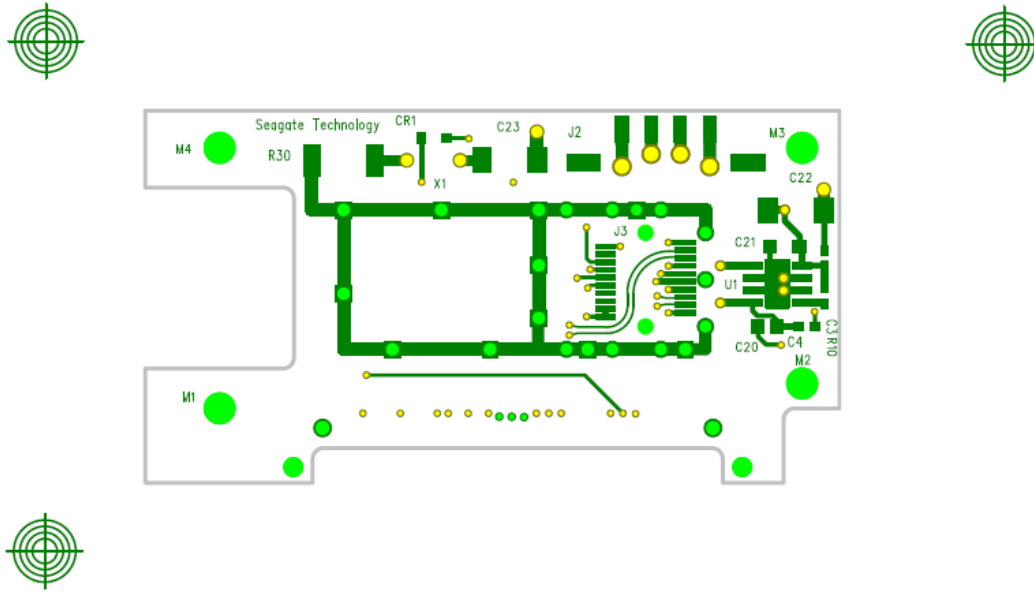

Figure 9 Single port T-Card schematic

8.2 Circuit board layout

An example layout of the single port T-Card is provided in Figure 10, Figure 11, Figure 12, and Figure 13. A Gerber version of the layout is included in the zip file available under this specification number.



CTE402-1 LAYER 1 (TOP)
LAST MODIFIED 10-20-11

Figure 10 Top layer

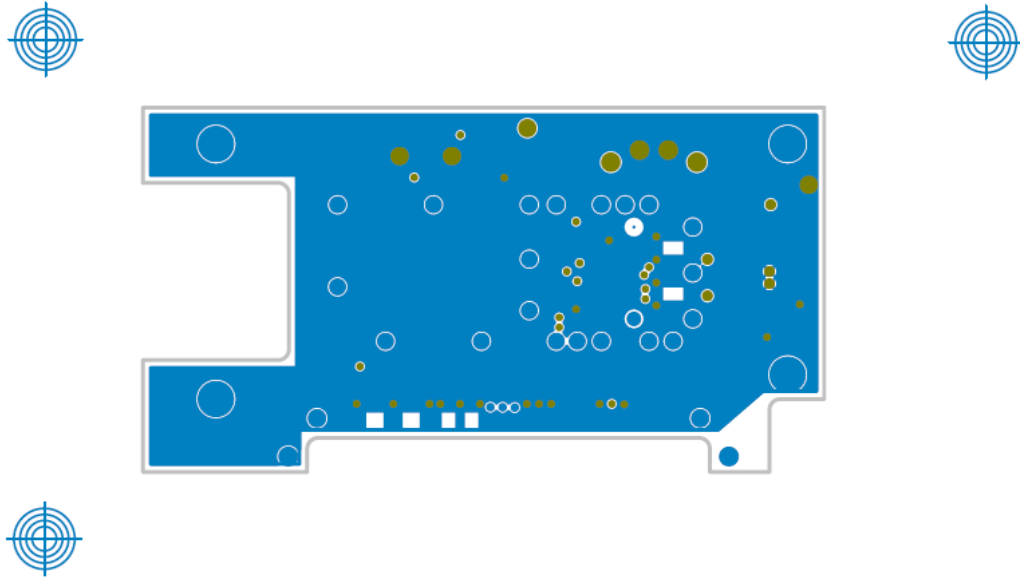

CTE402-1 LAYER 2 (GND)
LAST MODIFIED 10-20-11

Figure 11 Layer 2

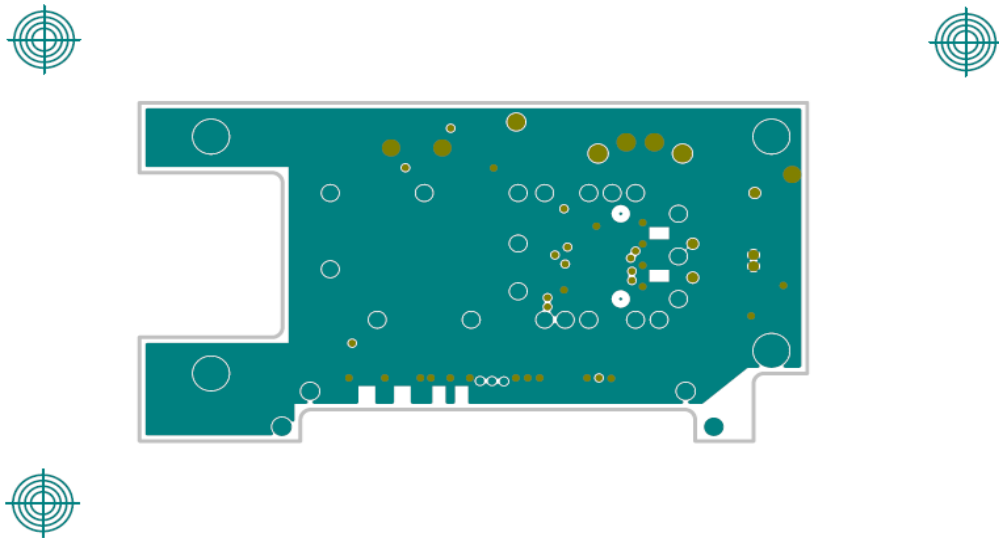

CTE402-1 LAYER 3 (GND)
LAST MODIFIED 10-20-11

Figure 12 Layer 3

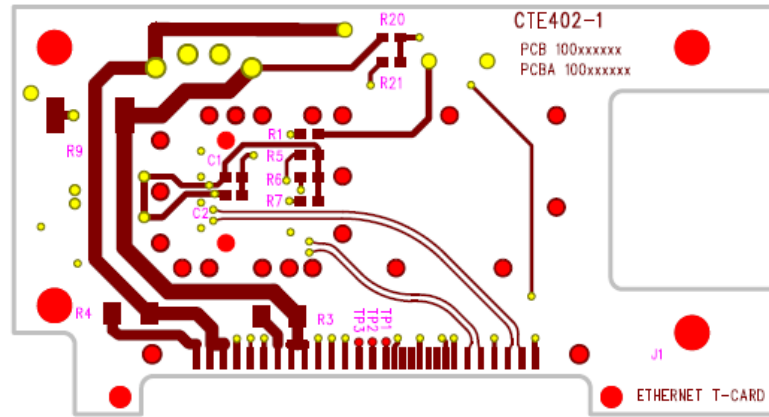

CTE402-1 LAYER 4 (BOTTOM)
LAST MODIFIED 10-20-11

Figure 13 Bottom layer

8.3 Assembly Drawing

Figure 14 and Figure 15 show the assembly drawings for the top and bottom of the example single port T-Card, respectively. The assembly drawing is also available in PDF format in the zip file available under this specification number.

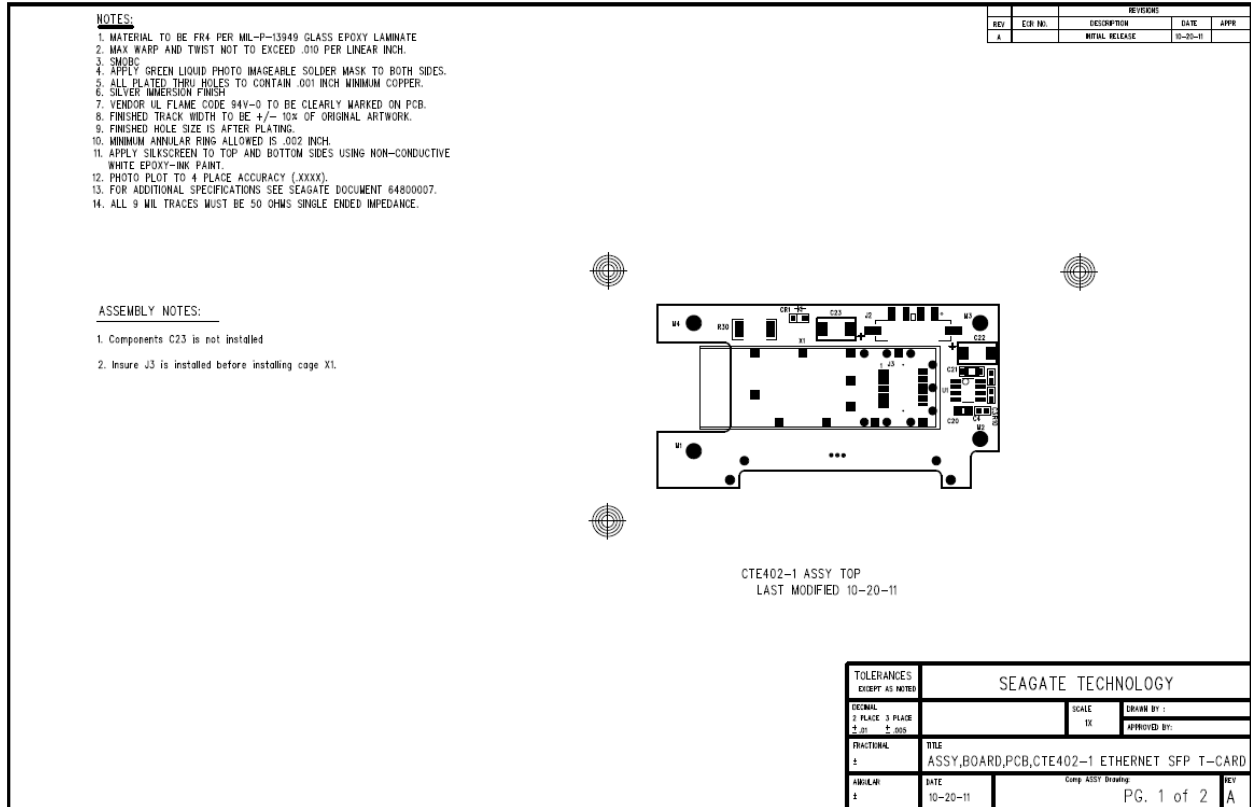

Figure 14 Assembly top

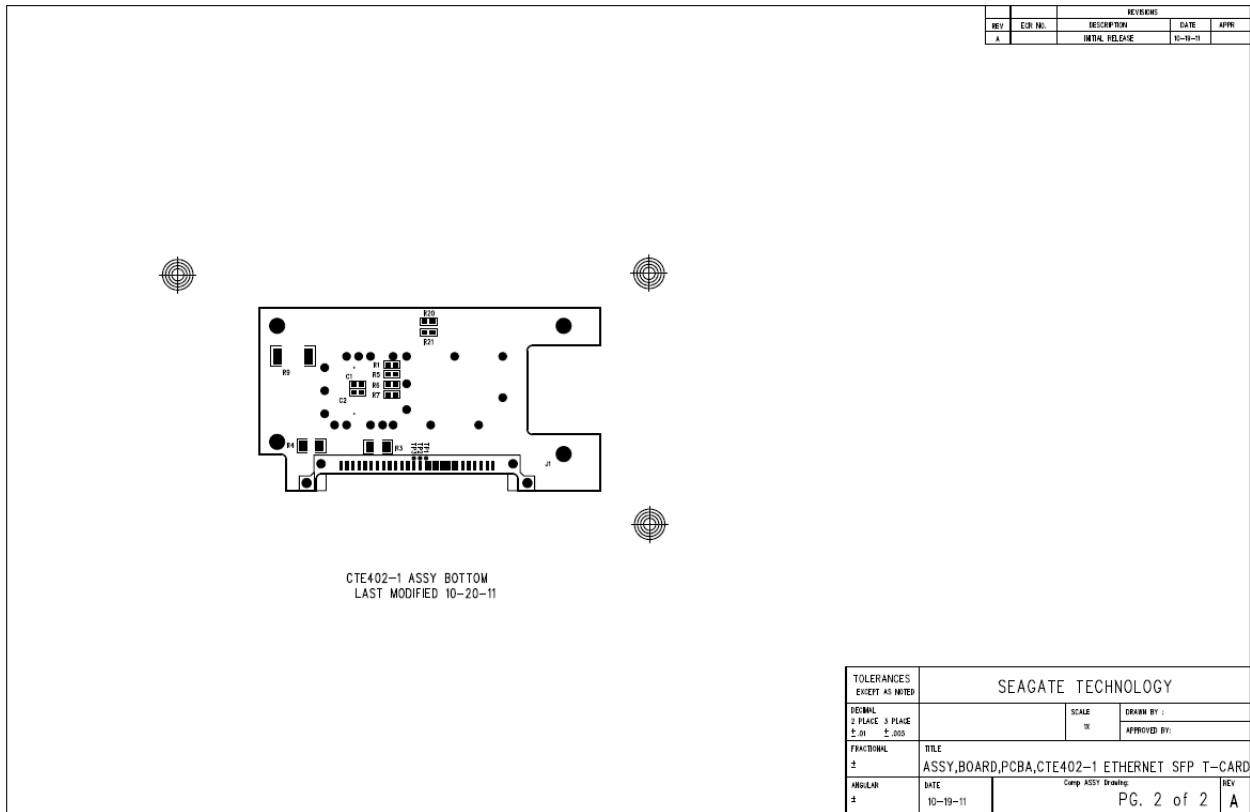

Figure 15 Assembly bottom

8.4 Bill of materials

The bill of materials in Table 4 provides a detailed list of components required to assemble the example single port T-Card. The bill of materials does not include the SFP Transceiver required. Details for the SFP Transceiver are defined in 7.3. The bill of materials is also available in xls format in the zip file available under this specification number.

Table 4 Bill of materials

Reference numbers	Qty	DESCRIPTION	MANUFACTURER	
			MFR NAME	PART NUMBER
U1	1	COML,IC,REG,UCC381-3,1A,LDO,SO8	TI	UCC381DP-3
J1	1	COML,CONNECTOR,RCPT,29PIN,0.05IN CTR,STRADDLE	FCI connect	10035202-001LF
J2	1	COML,CONNECTOR,HDR,4PIN,3MM MICRO-FIT,SMD,VERT,SOLDER TAB	Molex	0436500424
J3	1	CONN,PLUG,20PIN,0.8MM CTR,SMT	Molex	74440
X1	1	COML,CONNECTOR,CAGE ASSEMBLY,SOLDER PIN,SFP	Tyco	1489962-1
R1	1	RES,FXD,TKF,0603,0 OHM,1 PCT,1/10W	Vishay/Dale	CRCW0603000ZRT1
R30,R9	2	RES,FXD,TKF,2512,0.2OHM,1 PCT,1W	Vishay/Dale	CRCW2512R200FNEGLR
R3,R4	2	COML,RESISTOR,1206,1OHM, .5W, 1 PCT	Vishay/Dale	CRCW12061R00FKEAHP
R20	1	RES,FXD,TKF,0603,1.1K OHM,1 PCT,1/10W	ROHM	MCR03EZPFX1101
R21	1	RES,FXD,TKF,0603,2K OHM,1 PCT,1/10W	ROHM	MCR03EZPFX2001
R5,R6,R7, R10	4	RES,FXD,TKF,0603,10.0K OHM,1 PCT,1/10W	Vishay/Dale	CRCW060310K0FKEA
C1,C2,C3, C4	4	COML,CAPACITOR,.1UF 16V CERAMIC X7R 0603	Panasonic	ECG, ECJ-1VB1C104K,
C20	1	CAP,CER,10.0UF,0805,X5R,6.3V,10PCT,DC	TDK	C2012X5R0J106KT
C21	1	CAP,CER,10.0UF,1206,X5R,10.0V,10PCT,ROHS,D C	TDK	C3216X5R1A106KT
C22	1	COML,CAPACITOR,TANT,22UF,1 PCT,20V,SM-D	Kemet	T491D226K020AT
CR1	1	LED,SMT,GRN,10.0MA,4.0V,LN1371	Panasonic	LN1371SGTRP
	1	FAB,BOARD,PCB, CTE402-1		