

OPEN

Compute Project

Project Olympus Air Blocker Specification

Author:

Larry Cannon, Senior Mechanical Engineer, Microsoft

Revision History

Date	Description
11/01/2017	Version 1.0 Release to OCP



© 2017 Microsoft Corporation.

As of November 1, 2017, the following persons or entities have made this Specification available under the Open Web Foundation Final Specification Agreement (OWFa 1.0), which is available at <http://www.openwebfoundation.org/legal/the-owf-1-0-agreements/owfa-1-0>

Microsoft Corporation.

You can review the signed copies of the Open Web Foundation Agreement Version 1.0 for this Specification at [Project Olympus License Agreements](#), which may also include additional parties to those listed above.

Your use of this Specification may be subject to other third party rights. THIS SPECIFICATION IS PROVIDED "AS IS." The contributors expressly disclaim any warranties (express, implied, or otherwise), including implied warranties of merchantability, non-infringement, fitness for a particular purpose, or title, related to the Specification. The entire risk as to implementing or otherwise using the Specification is assumed by the Specification implementer and user. IN NO EVENT WILL ANY PARTY BE LIABLE TO ANY OTHER PARTY FOR LOST PROFITS OR ANY FORM OF INDIRECT, SPECIAL, INCIDENTAL, OR CONSEQUENTIAL DAMAGES OF ANY CHARACTER FROM ANY CAUSES OF ACTION OF ANY KIND WITH RESPECT TO THIS SPECIFICATION OR ITS GOVERNING AGREEMENT, WHETHER BASED ON BREACH OF CONTRACT, TORT (INCLUDING NEGLIGENCE), OR OTHERWISE, AND WHETHER OR NOT THE OTHER PARTY HAS BEEN ADVISED OF THE POSSIBILITY OF SUCH DAMAGE.

CONTRIBUTORS AND LICENSORS OF THIS SPECIFICATION MAY HAVE MENTIONED CERTAIN TECHNOLOGIES THAT ARE MERELY REFERENCED WITHIN THIS SPECIFICATION AND NOT LICENSED UNDER THE OWF CLA OR OWFa. THE FOLLOWING IS A LIST OF MERELY REFERENCED TECHNOLOGY: INTELLIGENT PLATFORM MANAGEMENT INTERFACE (IPMI); I²C IS A TRADEMARK AND TECHNOLOGY OF NXP SEMICONDUCTORS ; EPYC IS A TRADEMARK AND TECHNOLOGY OF ADVANCED MICRO DEVICES INC.; ASPEED AST 2400/2500 FAMILY PROCESSORS IS A TECHNOLOGY OF ASPEED TECHNOLOGY INC.; MOLEX NANOPITCH, NANO PICOBLADE, AND MINI-FIT JR AND ASSOCIATED CONNECTORS ARE TRADEMARKS AND TECHNOLOGIES OF MOLEX LLC; WINBOND IS A TRADEMARK OF WINBOND ELECTRONICS CORPORATION; NVLINK IS A TECHNOLOGY OF NVIDIA; INTEL XEON SCALABLE PROCESSORS, INTEL QUICKASSIST TECHNOLOGY, INTEL HYPER-THREADING TECHNOLOGY, ENHANCED INTEL SPEEDSTEP TECHNOLOGY, INTEL VIRTUALIZATION TECHNOLOGY, INTEL SERVER PLATFORM SERVICES, INTEL MANAGABILITY ENGINE, AND INTEL TRUSTED EXECUTION TECHNOLOGY ARE TRADEMARKS AND TECHNOLOGIES OF INTEL CORPORATION; SITARA ARM CORTEX-A9 PROCESSOR IS A TRADEMARK AND TECHNOLOGY OF TEXAS INSTRUMENTS; GUIDE PINS FROM PENCOM; BATTERIES FROM PANASONIC. IMPLEMENTATION OF THESE TECHNOLOGIES MAY BE SUBJECT TO THEIR OWN LEGAL TERMS.

List of Figures

Figure 1 - Iso views of Project Olympus Air Blockers	4
Figure 2. Iso View of Air Blockers in Rack	5
Figure 3 - Rear Iso Showing Air Blockers Installed	6

Project Olympus Air Blocker

The Project Olympus air blocker is a flame-rated, injection molded part that prevents cold aisle air from entering the rack in unpopulated U locations. It is designed to work in any rack with EIA rails punched with 9.5 x 9.5mm holes, the mounting hole center-to-center dimension across the rack being 465mm. The blocker is designed to be reversible, so that it may be used in open U locations, and in U locations that have Project Olympus Chassis Tracks. See Figures 1, 2, and 3.

Mounting to the rack is done by features that snap around the inside edges of the EIA rails. The upper and lower surfaces of the blockers seal against smooth flat surfaces – such as blade chasses and covers – both above and below them. The blockers seal against each other when mounted in multiples.

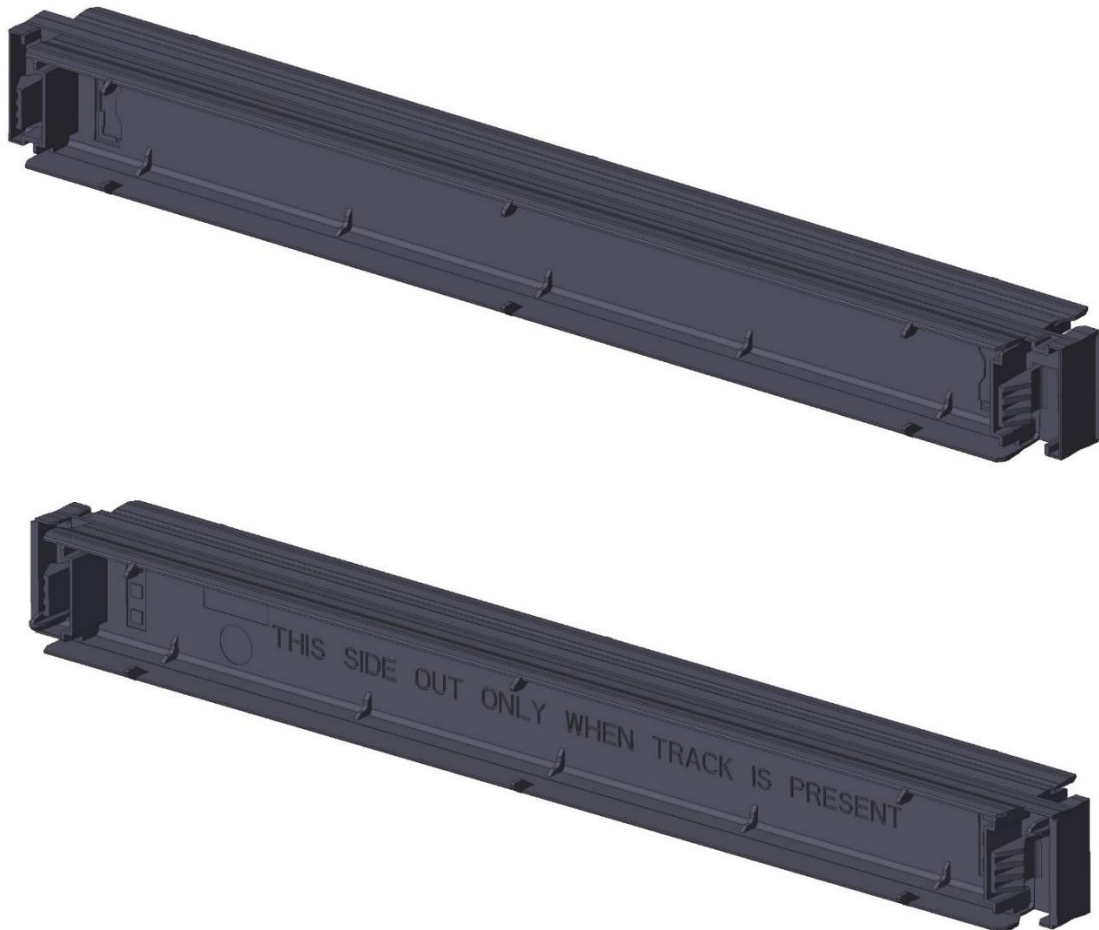

Figure 1 - Iso views of Project Olympus Air Blockers

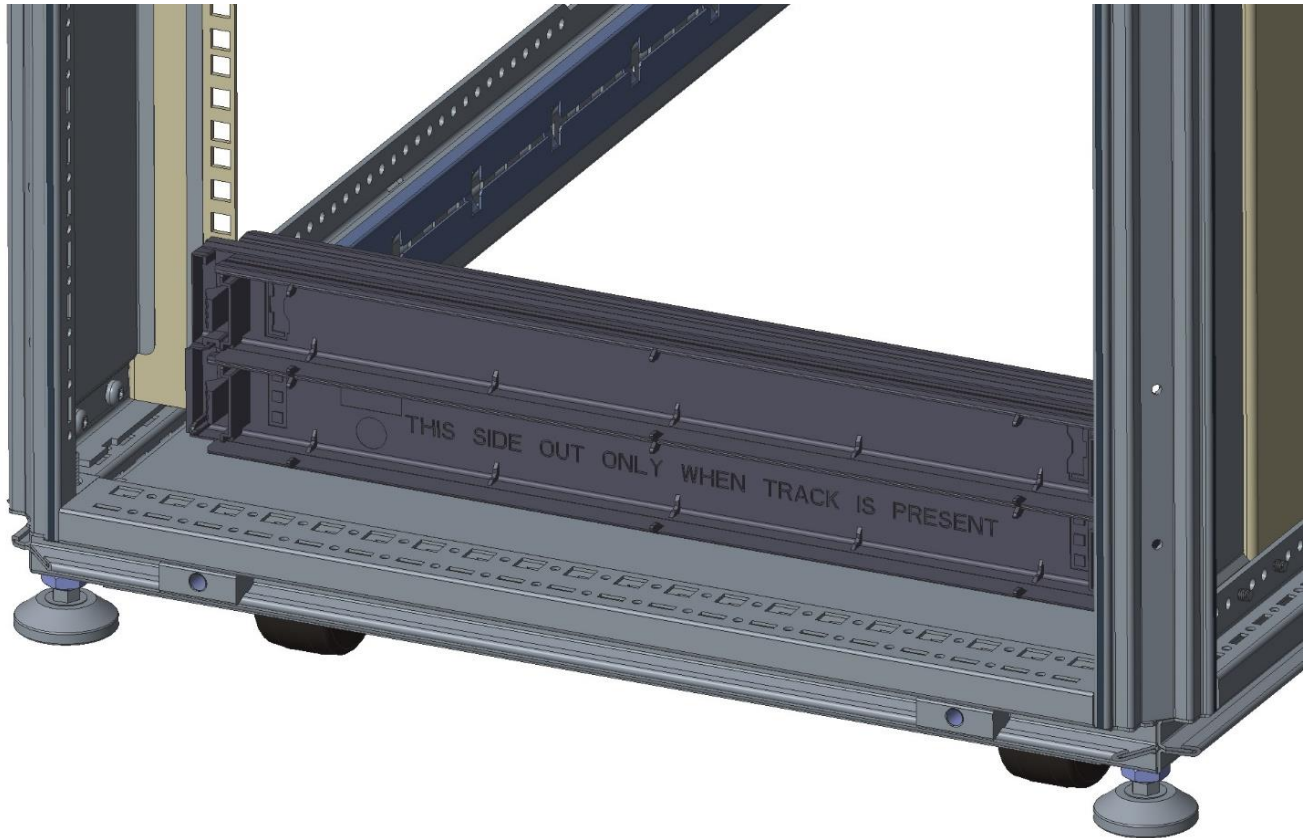

Figure 2. Iso View of Air Blockers in Rack

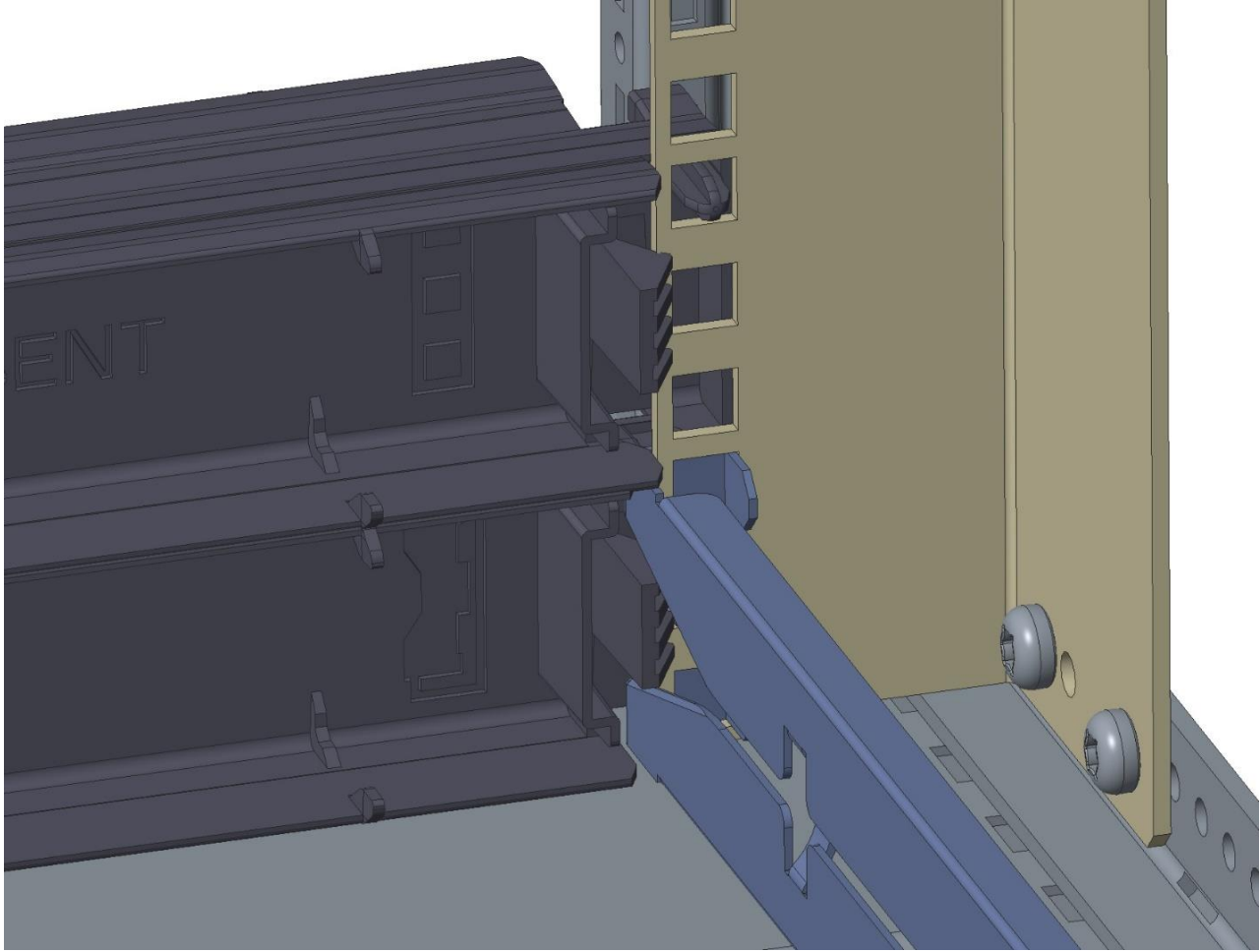

Figure 3 - Rear Iso Showing Air Blockers Installed