

Edgecore AS5900-54X

Switch Specification

Revision 1.1



OPEN
Compute Project

Revision History

Revision	Date	Author	Description
.01	2/25/2016	Jeff Catlin	Initial Release
1.0	7/19/2017	Jeff Catlin	Minor update to licensing section
1.1	8/4/2017	Jeff Catlin	Minor edit to license text

Contents

Revision History.....	2
Licenses	6
Scope.....	9
Overview	9
Physical Overview	10
Dimensions.....	10
Top View.....	11
Front View	12
Front Panel LED Definitions	12
SFP / QSFP28 Interface Module Support	13
Rear View	14
Field Replaceable Units	15
Power Supply Modules.....	15
PSU Pin-Out.....	16
Fan Modules.....	17
Fan Connector pinout	17
System Overview:	18
Main PCB Block Diagram	18
X86 Broadwell-DE CPU Module Block Diagram	19
T2080 CPU Module Block Diagram	20
X86 Rangeley CPU Module Block Diagram	21
PCB Board Set.....	22
Main Switch PCB	23
Main PCB Dimensions.....	23
Main PCB major components.....	23
Main PCB Top view	24
Main PCB Bottom View	25
Fan PCB	25

Fan PCB top side.....	25
Fan PCB bottom side	26
Fan PCB Dimensions	26
Fan PCB major components	26
Fan PCB connector pinout	26
Fan Cable Pinout	27
X86 Broadwell-DE CPU Module PCB	28
X86 Broadwell-DE CPU PCB Top side	28
X86 Broadwell-DE CPU PCB Bottom side	29
X86 Broadwell-DE CPU PCB Dimensions.....	29
X86 Broadwell-DE CPU PCB major components	29
T2080 CPU Module PCB	30
T2080 CPU PCB Top side	30
T2080 CPU PCB Bottom side	31
CPU PCB Dimensions.....	31
CPU PCB major components	31
X86 Rangeley CPU Module PCB	32
X86 Rangeley CPU PCB Top and Bottom side	32
X86 Rangeley CPU PCB Dimensions	32
X86 Rangeley CPU PCB major components	32
120 Pin CPU PCB to Main PCB Connector.....	33
Thermal Monitoring	34
Main PCB Thermal sensor locations.....	34
X86 Broadwell-DE CPU Module thermal sensor location	34
T2080 CPU Module thermal sensor location	35
X86 Rangeley CPU Module thermal sensor	35
Software Support	36
BIOS support.....	36
U-Boot.....	36
ONIE	36
Open Network Linux.....	36

Specifications	37
Power Consumption	37
Environmental	37
Safety	37
Electromagnetic Compatibility	37
ROHS	37

Licenses

All semiconductor devices that may be referred to in this specification, or required to manufacture products described in this specification, will be considered referenced only, and no intellectual property rights embodied in or covering such semiconductor devices shall be licensed as a result of this specification or such references. Notwithstanding anything to the contrary in the CLA, the licenses set forth therein do not apply to the intellectual property rights included in or related to the semi-conductor devices identifies in the specification. These references include without limitation the reference to devices listed below. For clarity, no patent claim that reads on such semiconductor devices will be considered a “Granted Claim” under the applicable Contributor License Agreement for this specification.

Description	Manufacturer	Part Number
X86 Broadwell-DE CPU	Intel	XeonD-1548
SDRAM 4GB SO-DIMM w/ECC (x2 DDR4)	Micron	MTA18ASF1G72HZ-2G1A1
USB to NAND Flash 8GB	ATP	AF8GSSGH-AC2
SPI NOR Flash 8MB	Winbound	W25Q128FVSSIG
TPM	ST Microelectronics	ST33ZP24AR28PVSP
mSATA Connector	TE Connectivity	1775838-2
M.2 connector	Concraft	213BAAA42FA
BMC Connector	FOXCONN	AS0A626-H2S6-7H
Ethernet Controller	Intel	WGI210AT
CPLD	Altera	5M1270ZF256C5N
10GeB SPI Flash	Winbond	W25Q32FVSSIG
I210 SPI flash	Winbond	W25Q16DVSSIG
T2080 CPU	Freescale	T2080NSN8TTB
SDRAM (8GB per channel)	UNIGEN	UG10U7211P8UU-BDE *2
USB to NAND Flash 8GB	ATP	AF8GSSGH-AC2
NOR Flash 128MB	MICRON	JS28F00AM29EWHA
Trusted Platform Module (TPM)	ST	ST33ZP24AR28PVSK
mSATA Connector	TE	1775838-2
M.2 connector	CONCRAFT	213BAAA32FA
SD Connector	CVILUX	CSD-09A001D
X86 Rangeley CPU	Intel	C2538 – 2.4GHz 3.0V
SDRAM 4GB SO-DIMM w/ECC (x2)	Innodisk	M3D0-4GHS2LPC 4GB 1.35V
USB to NAND Flash 8GB	ATP	AF8GSSGH-AC1
SPI NOR Flash 8MB (x2)	Winbound	W25Q64FVSSIG

Trusted Platform Module (TPM)	STMicroelectronics	ST33ZP24AR28PVSP ST
FPGA	Microsemi	A2F200M3F-FGG256
mSATA Connector	TE Connectivity	1775838-2
B2B Connector	SAMTEC	BTH-060-01-F-D-RA-WT-K
Main PCB CPLD (3)	Altera	EP4CGX15BF14C8N5M1270ZF256C5N 3.3V FBGA256 LT/LF
AC Power Supply	3Y	YM-2651YBR Front to back airflow
AC Power Supply	3Y	YM-2651YCR Back to front airflow
DC Power Supply	3Y	YM-2651VBR Front to back airflow
DC Power Supply	3Y	YM-2651VCR Back to Front airflow
12V DC Power Module	Edge-Core	PSU 12V-60
Switching Silicon	Broadcom	BCM88375
TCAM	Broadcom	BCM52311
DDR 4 Packet Buffer (*16)	Samsung	K4A4G165WD-BCRC 256MX16 FBGA96
10/100/1000 PHY	Broadcom	BCM54616S
Fans	Sunon	PF40561BX-Q020-S99 (Front to Back airflow)
Fans	Sunon	PF40561BX-Q010-S99 (Back to front airflow)
Cage/Connector QSFP28 1x2	TE Connectivity	2227104-5
Cage/Connector QSFP28 2x2	TE Connectivity	2289129-5
Cage/Connector SFP+	TE Connectivity	2149490-6
Connector RJ45 2x1 (x1)	UDE	FS2G6

As of March 9, 2016 this specification is contributed under the OCP Contributor Licensing Agreement (OCP-CLA) by the following entities:

Acton Technology Corporation, through its subsidiary Edgecore Networks Corporation

Limitations of the OCP CLA license are noted below:

No Limitations

You can review the signed copies of the OCP-CLA for this specification on the OCP website. <http://www.opencompute.org/products/specsanddesign>

Usage of this specification is governed by the OCPHL permissive. You can review this license at <http://www.opencompute.org/participate/legal-documents/>

Your use of this Specification may be subject to other third-party rights. THIS SPECIFICATION IS PROVIDED "AS IS." The contributors expressly disclaim any warranties (express, implied, or otherwise), including implied warranties of merchantability, non-infringement, fitness for a particular purpose, or title, related to the Specification. The entire risk as to implementing or otherwise using the Specification is assumed by the Specification implementer and user. IN NO EVENT WILL ANY PARTY BE LIABLE TO ANY OTHER PARTY FOR LOST PROFITS OR ANY FORM OF INDIRECT, SPECIAL, INCIDENTAL, OR CONSEQUENTIAL DAMAGES OF ANY CHARACTER FROM ANY CAUSES OF ACTION OF ANY KIND WITH RESPECT TO THIS SPECIFICATION OR ITS GOVERNING AGREEMENT, WHETHER BASED ON BREACH OF CONTRACT, TORT (INCLUDING NEGLIGENCE), OR OTHERWISE, AND WHETHER OR NOT THE OTHER PARTY HAS BEEN ADVISED OF THE POSSIBILITY OF SUCH DAMAGE.

Scope

This document outlines the technical specifications for the Edgecore AS5900-54X Open Switch Platform submitted to the Open Compute Foundation.

Overview

This document describes the technical specifications of the AS5900-54X switch contributed by Edgecore Networks. The AS5900-54X is a cost optimized switch design focused on advanced Top of Rack deployments and/or Carrier Edge deployments which support 10G client connectivity and providing 100Gb uplinks to the network. The AS5900-54X switch supports 48 SFP+ ports that operate at 10Gb and six QSFP28 ports that operate at 100G/40G and 25G/50G with appropriate break out cables.

The AS5900-54X is a PHY-Less design with the SFP+/QSFP28 connections directly attaching to the Serdes interfaces of the Broadcom 88375 switching silicon providing the lowest cost, latency, and power.

AS5900-54X supports advanced features found in Carrier Edge switches such as:

- Expandable packet buffering which is connected directly to the BCM88375
 - Expandable TCAM through a BCM52311 for very deep table capacities which is connected directly to the BCM88375
 - Advanced traffic management capabilities integrated into the BCM88375
- The AS5900-54X is a 1RU design that supports standard 19" rack deployments as well as standard 21" Open Rack deployments with the ORSA-1RU.

Physical Overview

Dimensions

	Inches	Millimeters
Length	20.27	515
Width	17.26	438.4
Height	1.71	43.5

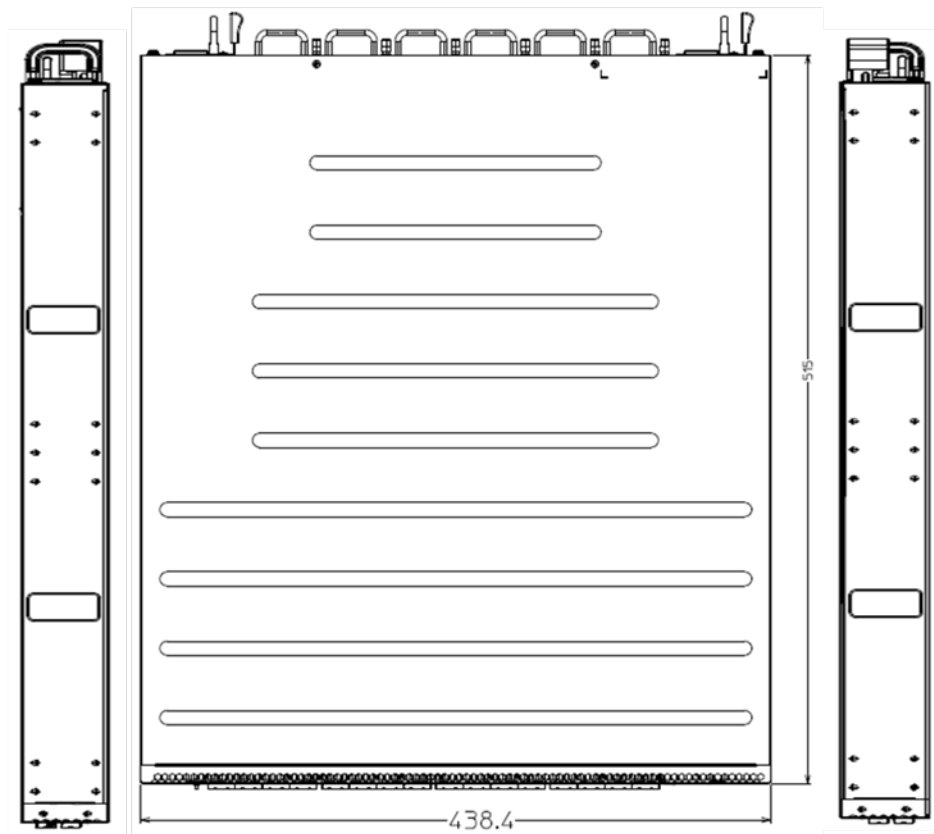

Top View

The top view of the AS5900-54X shows the PCBs and associated components in the AS5900-54X system

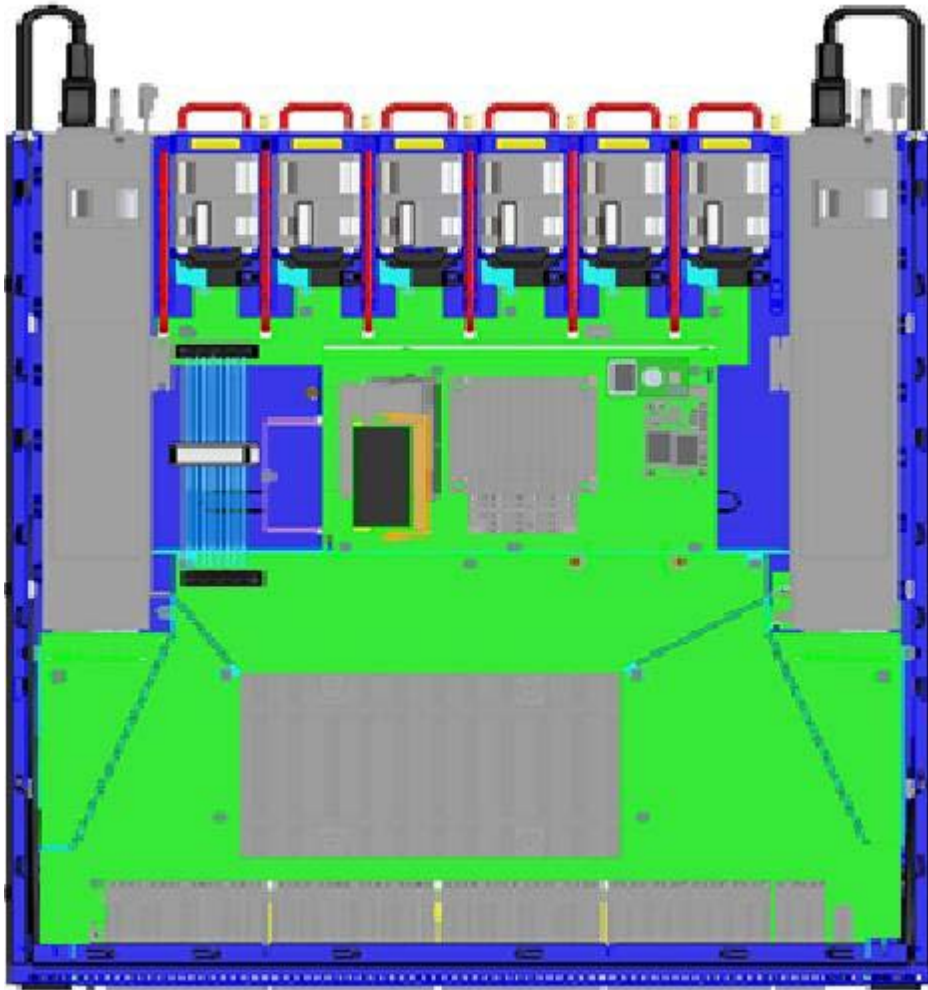

Front View



The front panel view of the AS5900-54X includes the following key components:

- Forty Eight SFP+ Ports
 - Capable of operating at 10Gb Ethernet speeds with standard SFP+ modules or 1Gb Ethernet speeds with SFP modules
- Six QSFP28 ports
 - Capable of operating at 100G /40Gb Ethernet with standard QSFP28/QSFP+ modules or 10Gb, 25G, 50G Ethernet via break out cables
- System LEDs
- Mini USB 2.0 type “A” port
 - Used for optional external storage
- RJ45 RS232 management port
 - Supports asynchronous mode with the default being eight data bits, one stop bit, no parity
- RJ45 10/100/1000 Ethernet management port
 - Connected directly to the system CPU
- Reset switch

Front Panel LED Definitions

LED Name	Description	State
PSU1	Led to indicate status of Power Supply 1	Green - Normal Amber - Fault Off – No Power
PSU2	Led to indicate status of Power Supply 1	Green - Normal Amber - Fault Off – No Power
Diag	LED to indicate system diagnostic test results	Green – Normal Amber – Fault detected

FAN	LED to indicate the status of the system fans	Green – All fans operational Amber – One or more fan fault	
LOC	LED to indicate Location of switch in Data Center	Amber Flashing – Set by management to locate switch Off – Function not active	
QSFP28 Port LED	LED 1	Blue	100G (4 x 25G)
		Orange	40G (4 x 10G)
		White	25G
		Yellow	50G
		Green	10G
		off	not present
	LED 2-4	Yellow	50G
		White	25G
		Green	10G
		off	not present
OOB LED	LED to indicate link status of 10/100/1000 management port	On - Green 1G Link On - Yellow 10/100 Link Flashing – Indicates activity	

SFP / QSFP28 Interface Module Support

SFP+ Module support	Standard 1Gb SFP modules including but not limited to: 1000Base-T, 1000BASE-SX, 1000BASE-LX, 1000BASE-EX Standard 10Gb SFP+ modules including but not limited to: 10GBASE-SR, 10GBASE-LR, 10GBASE-ER, AOC Cables Standard SFP+ DAC cables including but not limited to Passive cable up to 5m, Active cable up to 10m
40Gb QSFP+ Optical Modules	Standard 40Gb QSFP+ modules including but not limited to: 40GBASE-SR4, 40GBASE-LR4, 40GBASE-ER, AOC Cables
40Gb Direct Attach Copper (DAC)	Standard DAC cables including but not limited to: Passive cables up to 7m, QSFP<> QSFP DAC, QSFP<>SFP+ DAC Breakout

QSFP28 Optics	Support for all standards compliant QSFP28 XCVRS including but not limited to 100GBASE-SR4, 100GBASE-LR4
QSFP28 Direct Attach Copper (DAC)	Standard DAC cables including but not limited to: Passive cables up to 3m, QSFP28<> QSFP28 DAC, QSFP28<>SFP28 DAC Breakout

Rear View



The rear view of the AS5900-54X includes the following key components:

- Six (5+1) redundant hot swappable fan modules
 - LED per fan module to indicate status
 - Color coding to indicate airflow direction
- Two redundant hot swappable power supply modules
 - LED per power supply to indicate status
 - Color coding to indicate airflow direction

Field Replaceable Units

Power Supply Modules

The AS5900-54X supports two redundant power supply modules as listed below

3Y 650 Watt PSU: AC Input Range 90-264VAC / 47-63Hz		
<ul style="list-style-type: none"> • YM-2651YBR Front to back airflow • YM-2651YCR Back to front airflow 		
3Y 650W PSU: 48V DC Input range 36-75Vdc		
<ul style="list-style-type: none"> • YM-2651VBR -Front to back airflow • YM-2651VCR -Back to front airflow 		
Edge-Core 600 Watt 12V DC Module		
<ul style="list-style-type: none"> • PSU-12V-600 		
	<u>Inches</u>	<u>Millimeters</u>
Length	12.21	310.2
Width	1.58	50.5
Height	2.15	40

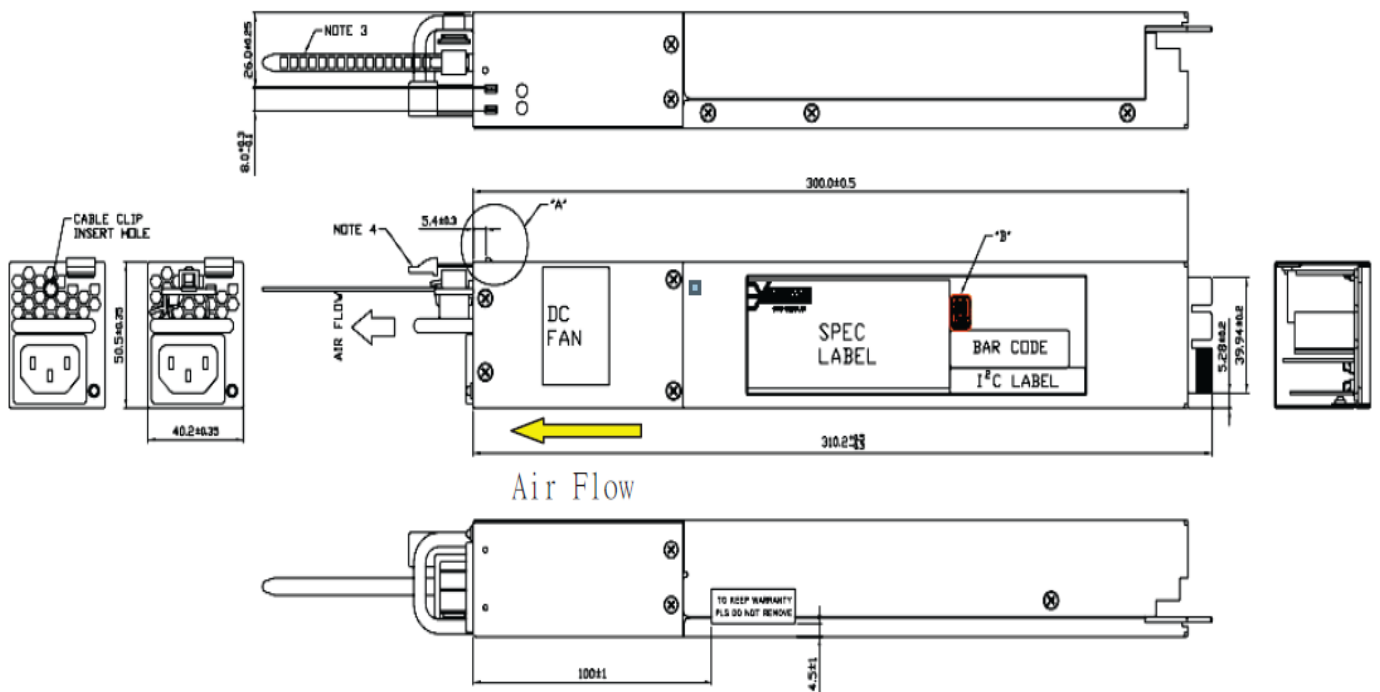

3.

PSU Pin-Out

3.3. Pin assignment for DC output gold fingers

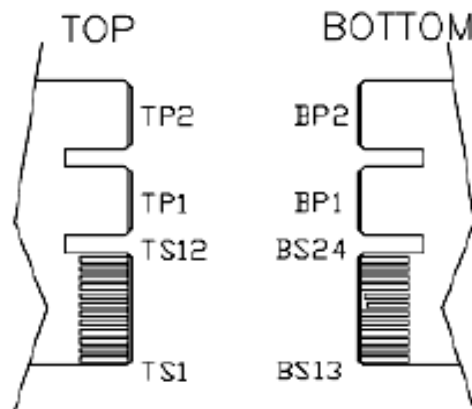

PIN NO.	CONDITION	PIN NO.	CONDITION
TS1	PDB_FAULT	BS13	+12VS+
TS2	PRESENT	BS14	+12VRS-
TS3	A0	BS15	12LS
TS4	PDB_ALERT	BS16	SMB_ALERT
TS5	AC-OK	BS17	SDA
TS6	Reserved	BS18	SCL
TS7	Reserved	BS19	PS-KILL
TS8	Reserved	BS20	PS_ON
TS9	Reserved	BS21	PW_OK
TS10	A2	BS22	A1
TS11	+5VSB	BS23	+5VSB
TS12	+5VSB	BS24	+5VSB
TP1	GND	BP1	+12V
TP2	GND	BP2	+12V
TOP		BOTTOM	

Figure 3: signal descriptions

Fan Modules

The AS5900-54X supports six individual fan modules. Each fan module supports two 40mmx40mmx56mm fans shown below.

Description	Manufacturer	Part Number
Fan – Front to back airflow	Sunon	PF40561BX-Q020-S99
Fan – Back to front airflow	Sunon	PF40561BX-Q010-S99

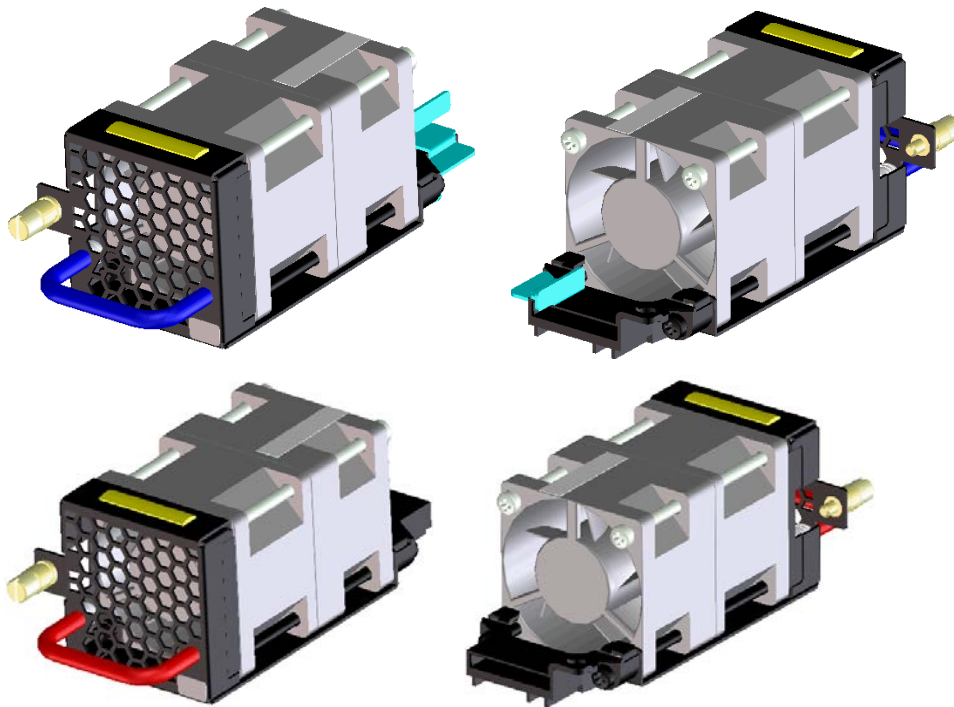

Fan Connector pinout

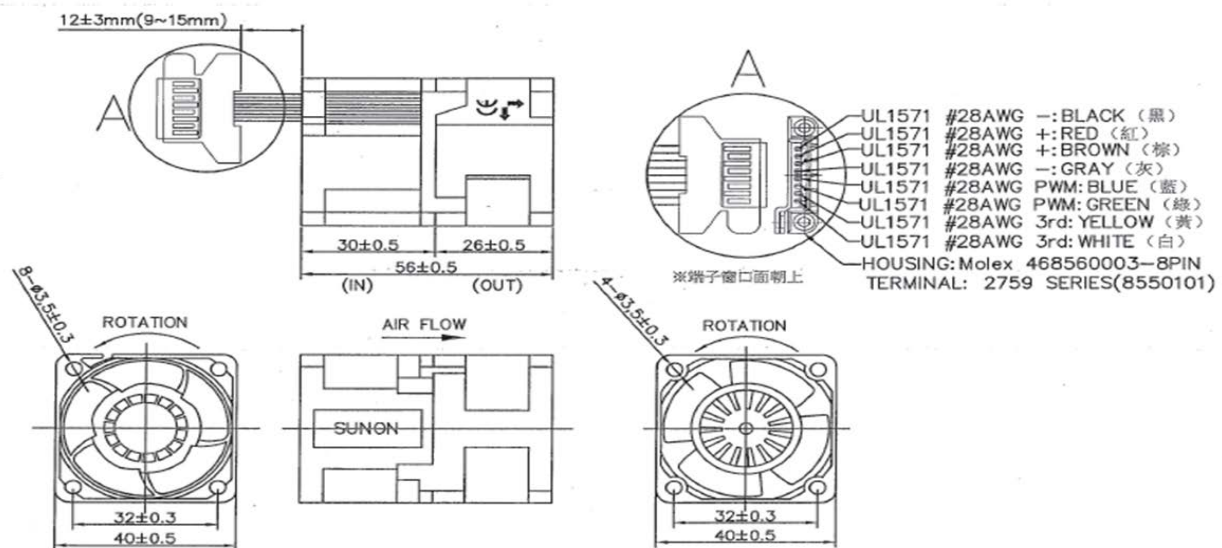

System Overview:

Main PCB Block Diagram

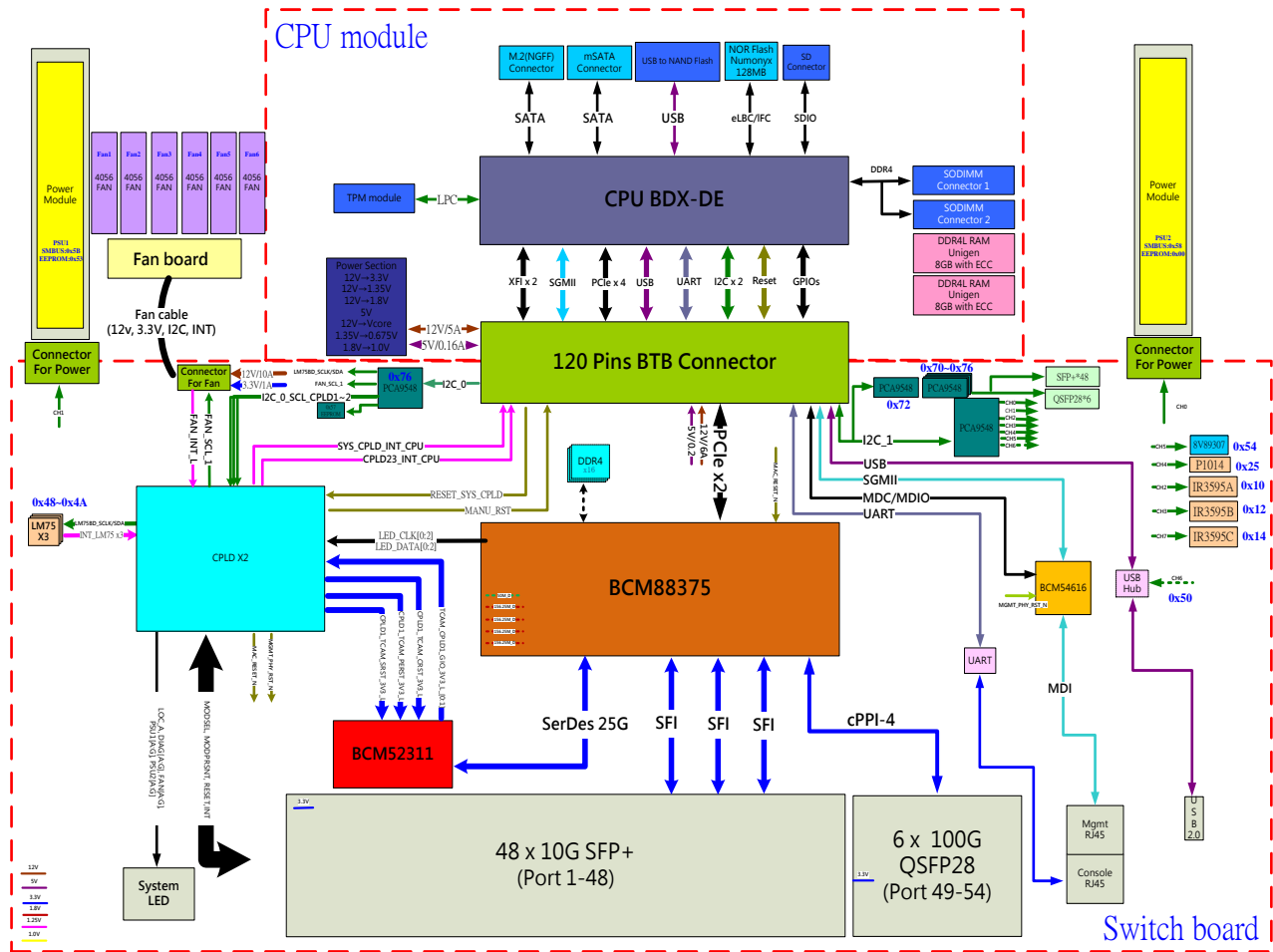

X86 Broadwell-DE CPU Module Block Diagram

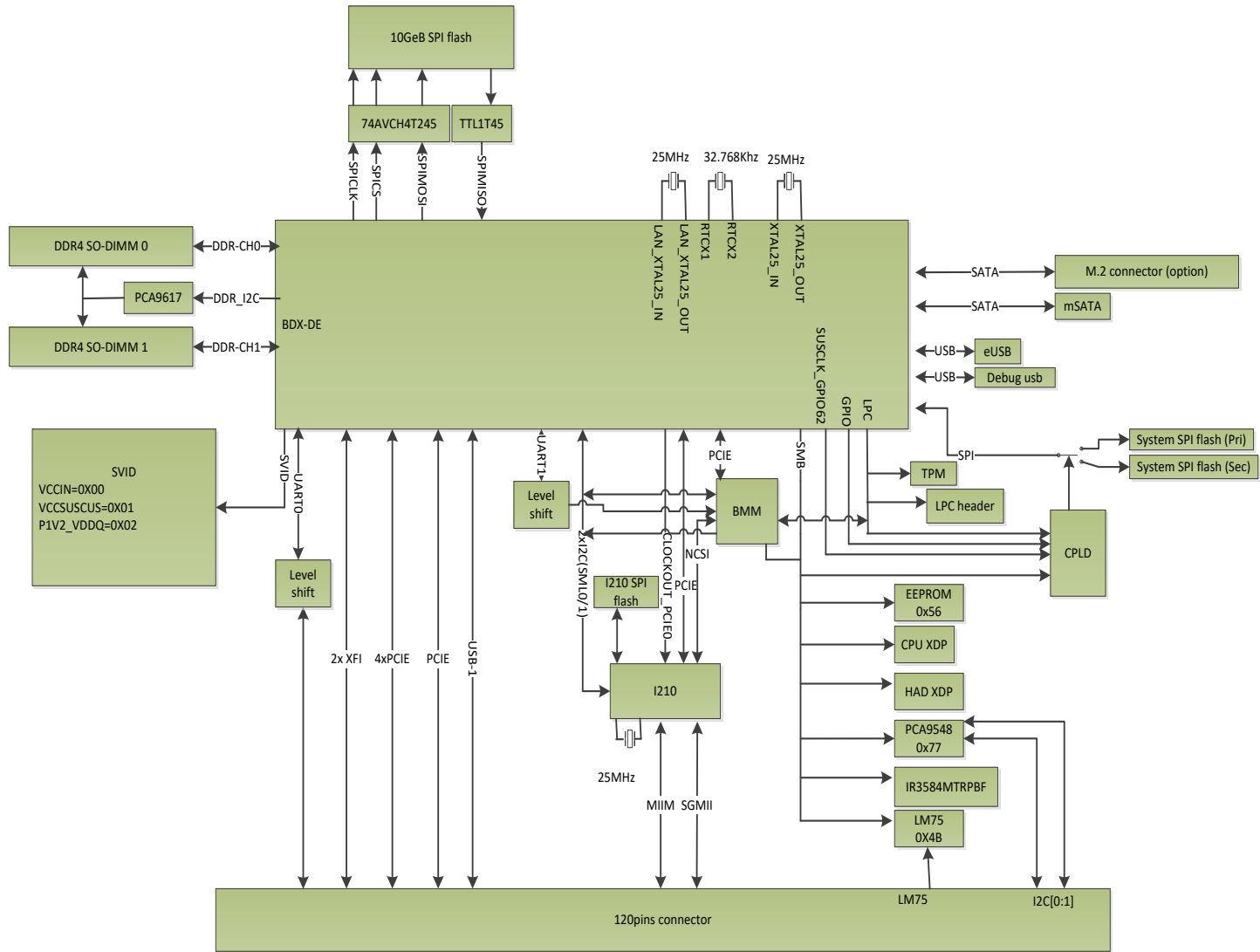

T2080 CPU Module Block Diagram

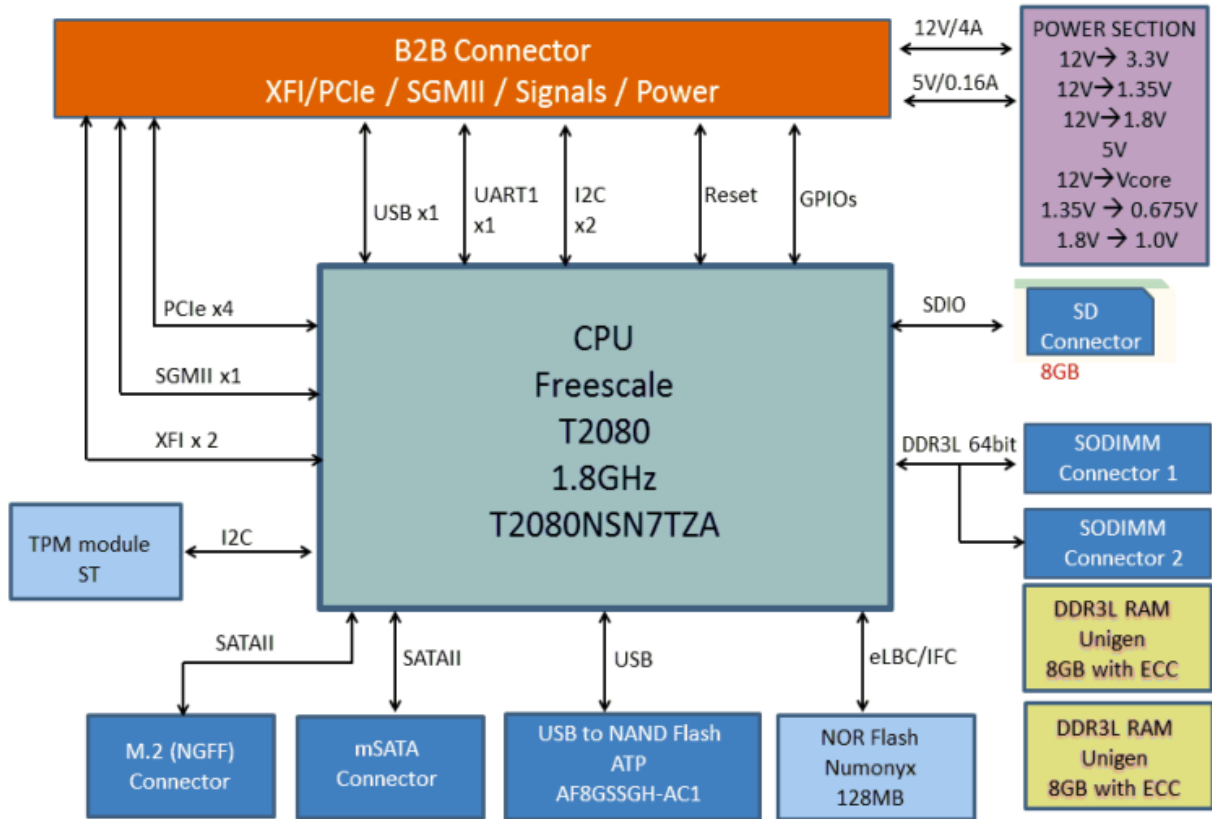

X86 Rangeley CPU Module Block Diagram

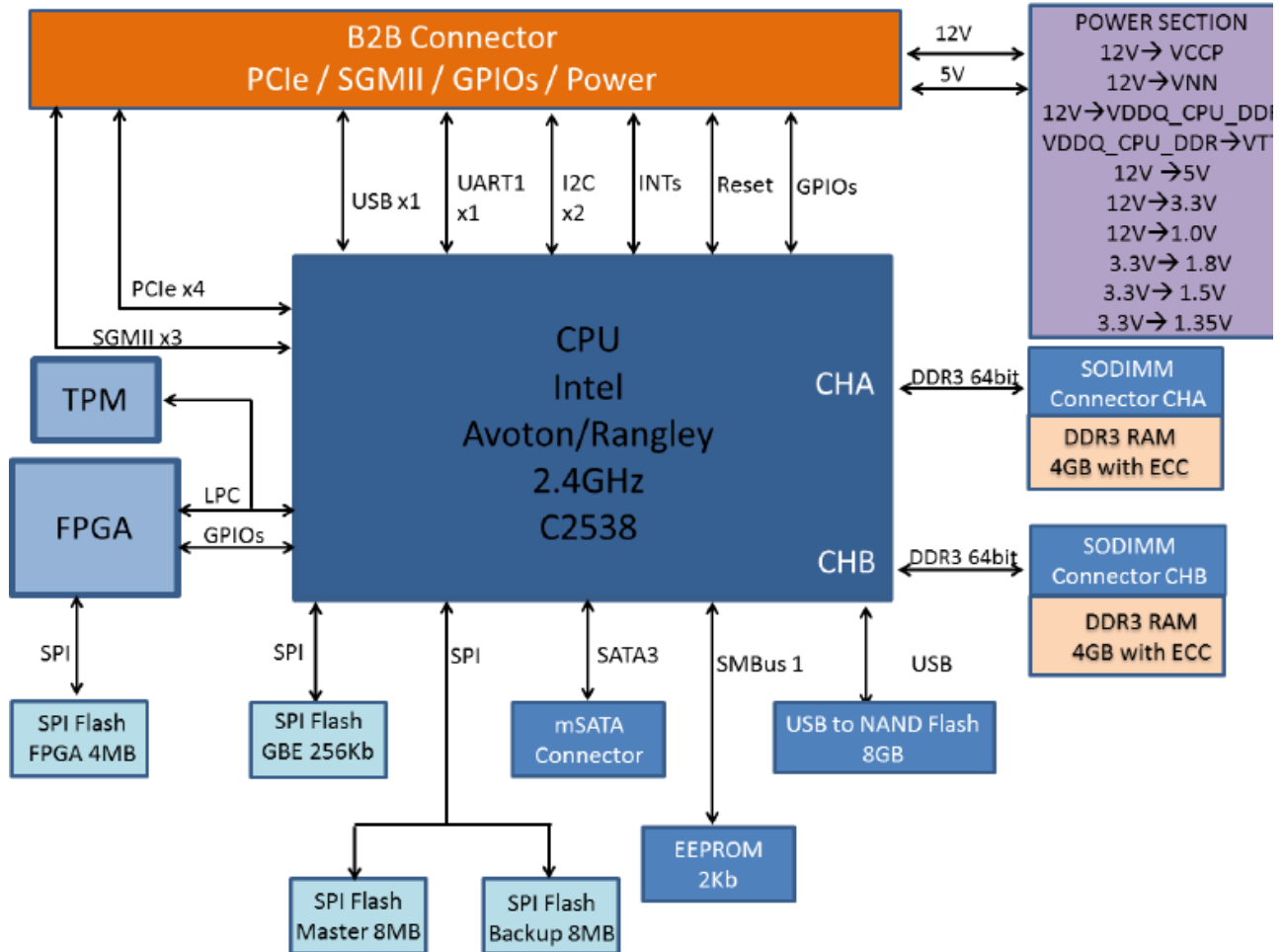

PCB Board Set

The AS5900-54X is composed of 5 unique PCB assemblies as follows:

- Main switch PCB which supports the switching silicon and all front panel connections
- X86 Broadwell-DE CPU module PCB which provides the control processor and associated components
- T2080 CPU module PCB which provides the control processor and associated components
- X86 Rangeley CPU module PCB which provides the control processor and associated components
- Fan PCB which provides connectivity for the 5 Fan modules in the system

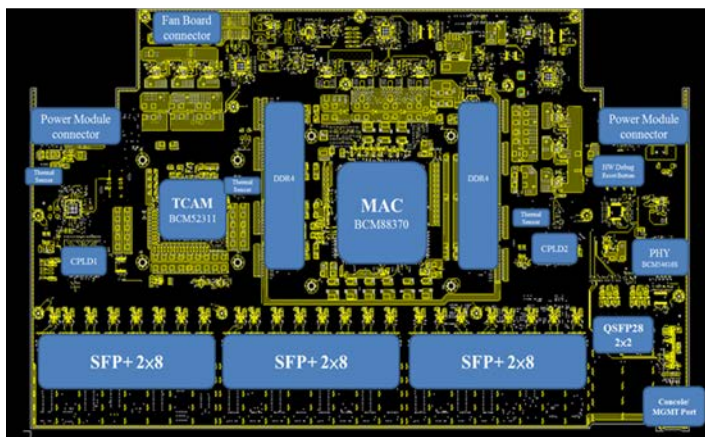
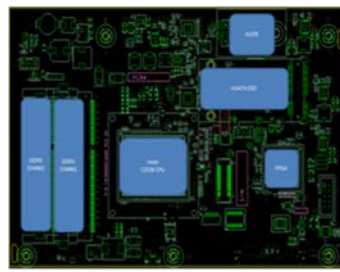
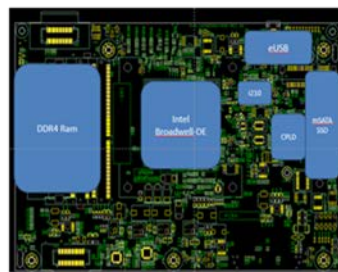
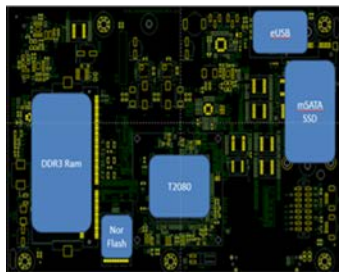
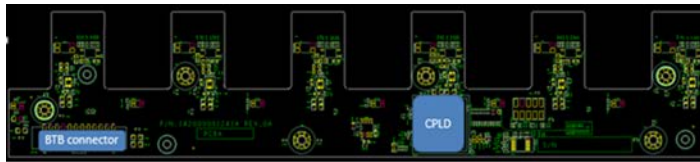

Main Switch PCB

The Main Switch PCB is a twenty two layer board supporting the switching silicon, front panel networking and management ports, LEDs, and connections to other PCBs required in building the system.

Main PCB Dimensions

	Inches	Millimeters
Length	10.17	258.5
Width	15.08	383

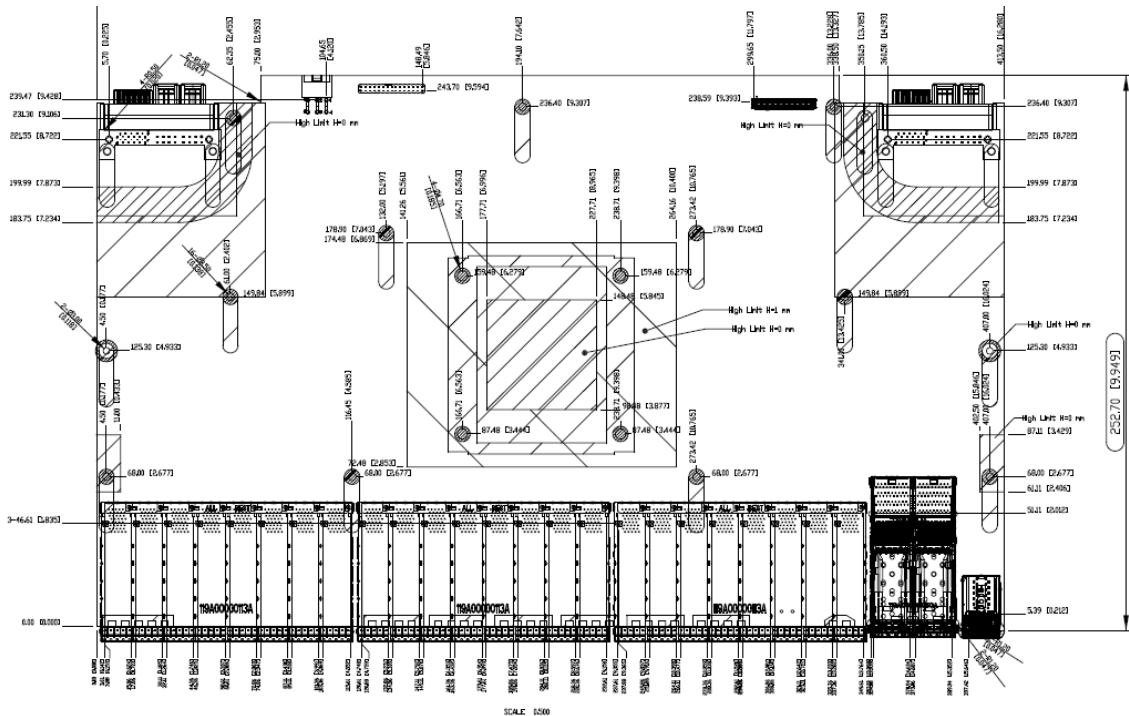

Main PCB major components

Description	Manufacturer	Part Number
Switching Silicon	Broadcom	BCM88375
10/100/1000 PHY	Broadcom	BCM54616S
TCAM	Broadcom	BCM52311
DDR 4 Packet Buffer (*16)	Samsung	K4A4G165WD-BCRC 256MX16 FBGA96
Fans	Sunon	PF40561BX-Q020-S99 (Front to Back airflow)
Fans	Sunon	PF40561BX-Q010-S99 (Back to front airflow)
Cage/Connector QSFP28 1x2	TE Connectivity	2227104-5
Cage/Connector QSFP28 2x2	TE Connectivity	2289129-5
Cage/Connector SFP+	TE Connectivity	2149490-6
FPGA	Altera	EP4CGX15BF14C8N

Connector RJ45 2x1 (x1)	UDE	FS2G6
CPLD	Altera	5M1270ZF256C5N 3.3V FBGA256 LT/LF (3
B2B Connector Fan PCB	DONG-WEI	BHE6T0-224S4
USB Connector	CZT	USB-A1D249F-4B4N
Power Connector	Alltop	C21442-126H5-Y
Reset Button	DAWNING	TS-A15E-BP-220-S085
ID Button	HUAI YANG	PS020-L12NPBAXX-1
B2B connector CPU Module	SAMTEC	BSH-060-01-F-D-RA-WT

Main PCB Top view

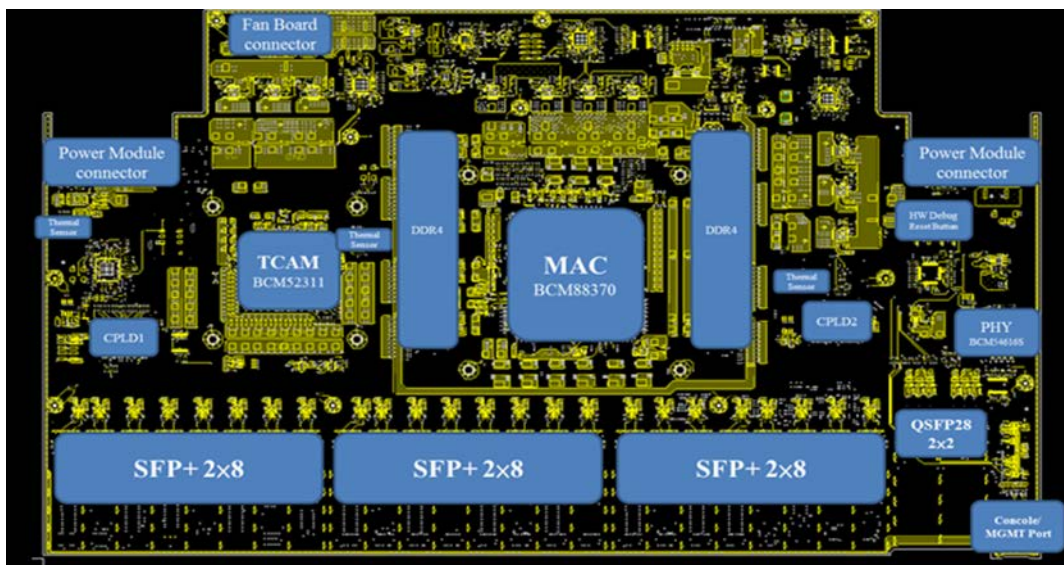

Main PCB Bottom View

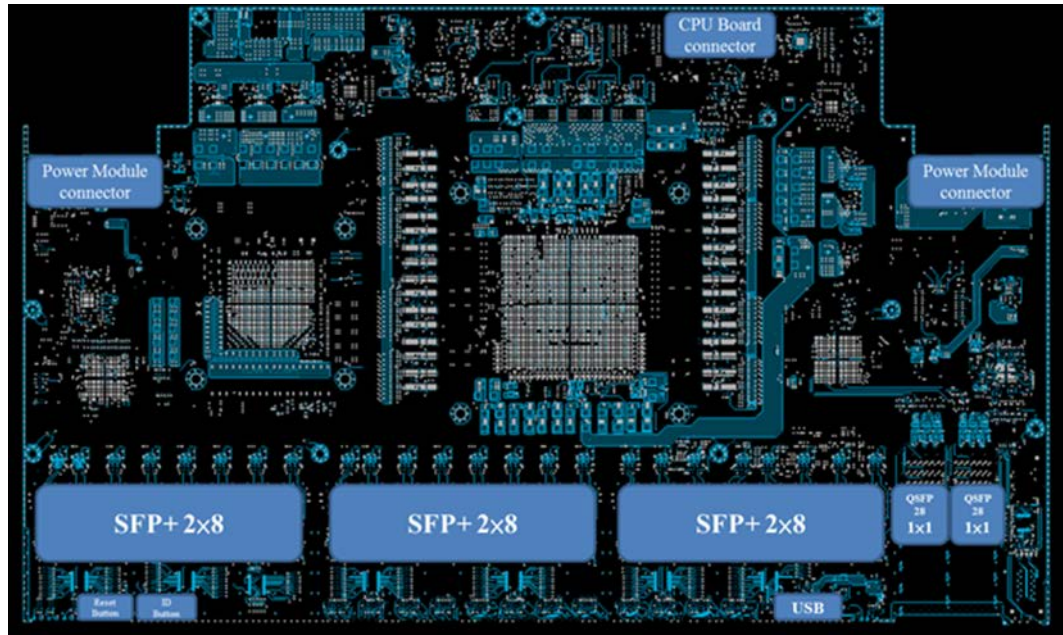

Fan PCB

The Fan PCB is four layers and provides the power, management and connectivity for the 6 system fan modules. The Fan PCB connects to the Main Switch PCB via a power and a signal cable assembly.

Fan PCB top side



Fan PCB bottom side

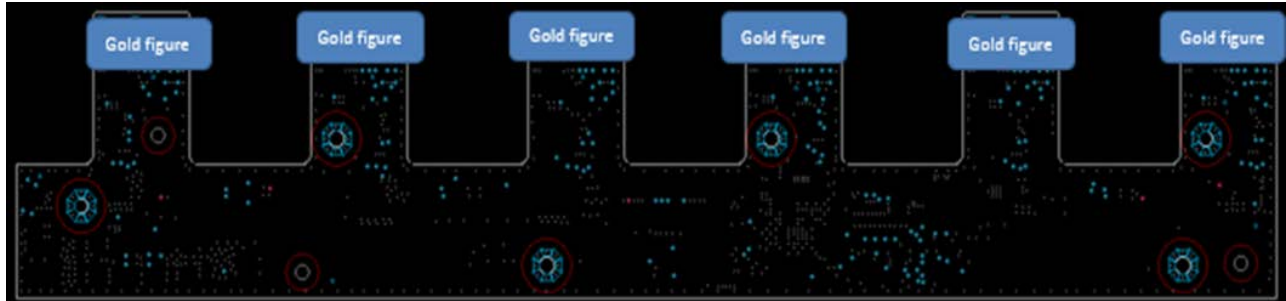

Fan PCB Dimensions

	<u>Inches</u>	<u>Millimeters</u>
Length	9.54	242.5
Width	2.40	60.9

Fan PCB major components

<u>Description</u>	<u>Manufacturer</u>	<u>Part Number</u>
B2B Connector	DONG-WEI	BHE6T0-224S4
CPLD	Altera	5M1270ZF256C5N 3.3V

Fan PCB connector pinout

Name	Type	Net Name	Description
1	power	VCC12	12V Power
2	power	VCC12	12V Power
3	power	VCC12	12V Power
4	power	VCC12	12V Power
5	power	GND	12V/ 3.3V return
6	power	GND	12V/ 3.3V return
7	power	GND	12V/ 3.3V return
8	power	VDD3P3	3.3V Power
9	out	FAN_IDLE	Enable/ disable the Fan board's I2C Master
10	in	FAN_INT_L	Fan board send interrupt
11	power	GND	12V/ 3.3V return

X86 Broadwell-DE CPU Module PCB

The x86 CPU module is a 12 layer PCB and supports the communication processor and associated components for the CPU subsystem. The communication processor utilized is an Intel® Xeon® processor D series communication processor. The Intel® Xeon® processor D product family is the first Intel® Xeon® SoC optimized to deliver Intel Xeon processor performance and enhanced total cost of ownership (TCO) for hyperscale workloads.

The Intel® Xeon® processor D product family supports high levels of I/O integrations, including 10GbE. The Intel Xeon processor D product family also includes data center processor features such as error correcting code (ECC). With high levels of I/O integration and energy efficiency.

X86 Broadwell-DE CPU PCB Top side

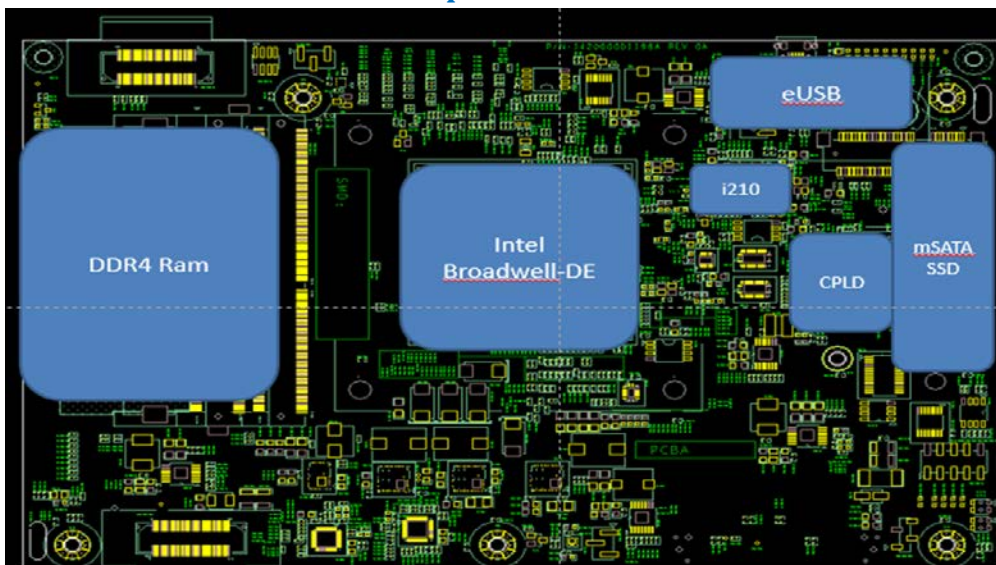

X86 Broadwell-DE CPU PCB Bottom side

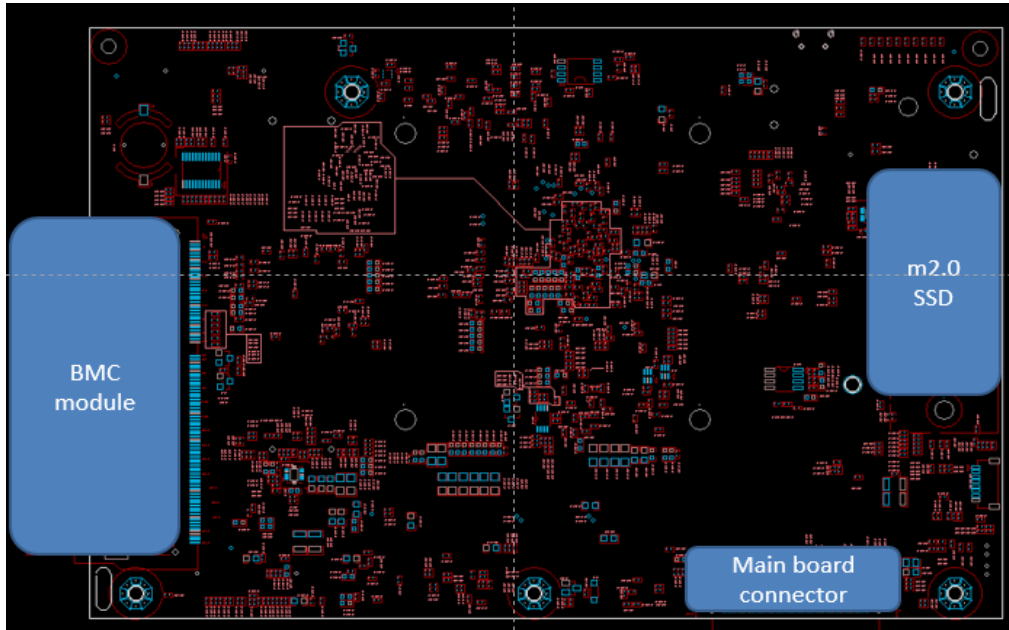

X86 Broadwell-DE CPU PCB Dimensions

	Inches	Millimeters
Length	7.32	186.02
Width	4.86	123.5

X86 Broadwell-DE CPU PCB major components

Description	Manufacturer	Part Number
CPU	Intel	XeonD-1548
SDRAM 8GB per channel	Micron	MTA18ASF1G72HZ-2G1A1
USB to NAND Flash 8GB	ATP	AF8GSSGH-AC2
SPI NOR Flash	Winbond	W25Q128FVSIQ
Trusted Platform Module (TPM)	ST	ST33ZP24AR28PVSP
mSATA Connector	TE	1775838-2
M.2 connector	Concraft	213BAAA42FA
BMC Connector	FOXCONN	AS0A626-H2S6-7H
B2B Connector	SAMTEC	BTH-060-01-F-D-RA-WT-K
Ethernet Controller	Intel	WGI210AT
CPLD	Altera	5M1270ZF256C5N
10Gb SPI Flash	Winbond	W25Q32FVSSIQ
I210 SPI flash	Winbond	W25Q16DVSSIQ

T2080 CPU Module PCB

The T2080 CPU module is an 8 layer PCB and supports the communication processor and associated components for the CPU subsystem. The communication processor utilized is the Freescale Semiconductor T2080 QorIQ processor. The T2080 QorIQ integrated multicore communications processor combines 4 dualthreaded cores built on Power Architecture® technology with high-performance data path acceleration and network and peripheral bus interfaces required for networking, telecom/ datacom, wireless infrastructure, and military/aerospace applications.

T2080 CPU PCB Top side

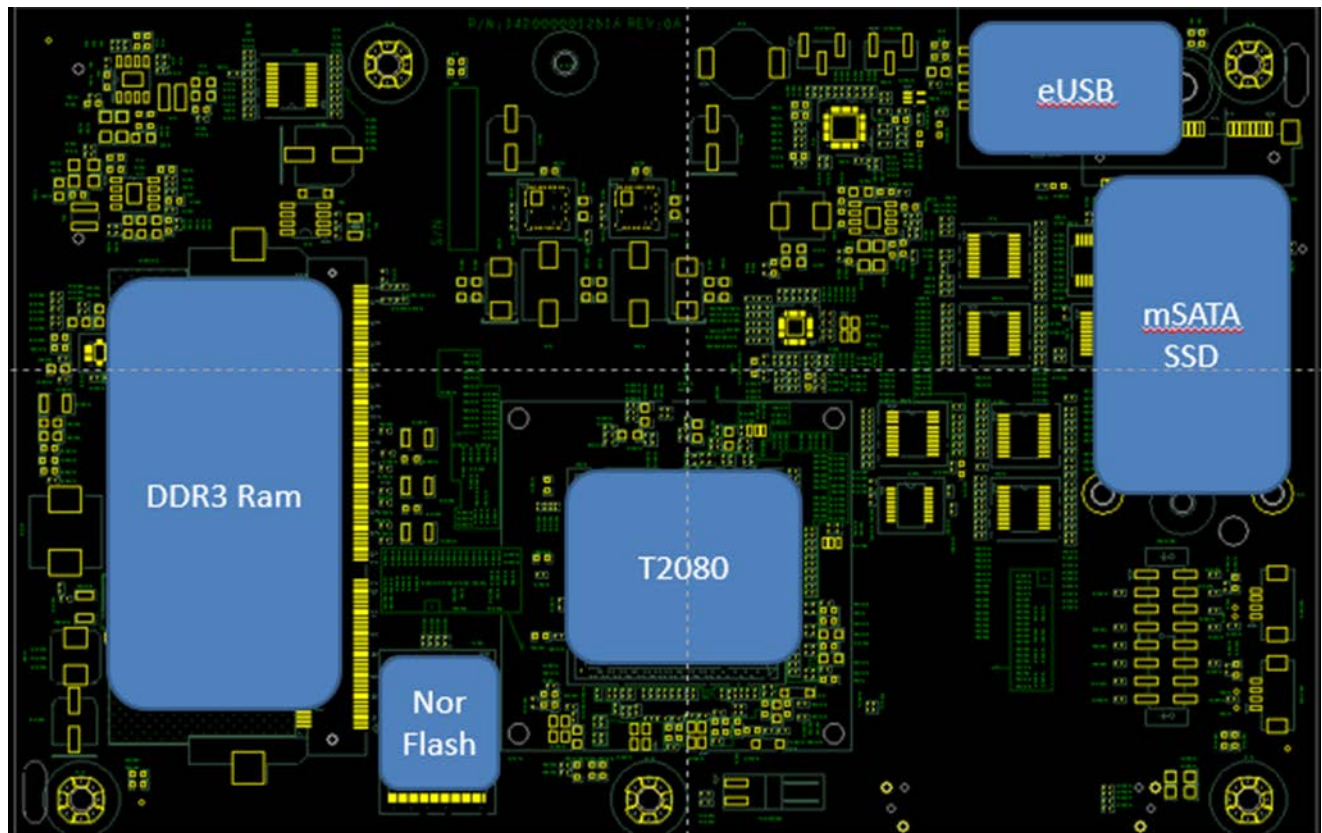

T2080 CPU PCB Bottom side

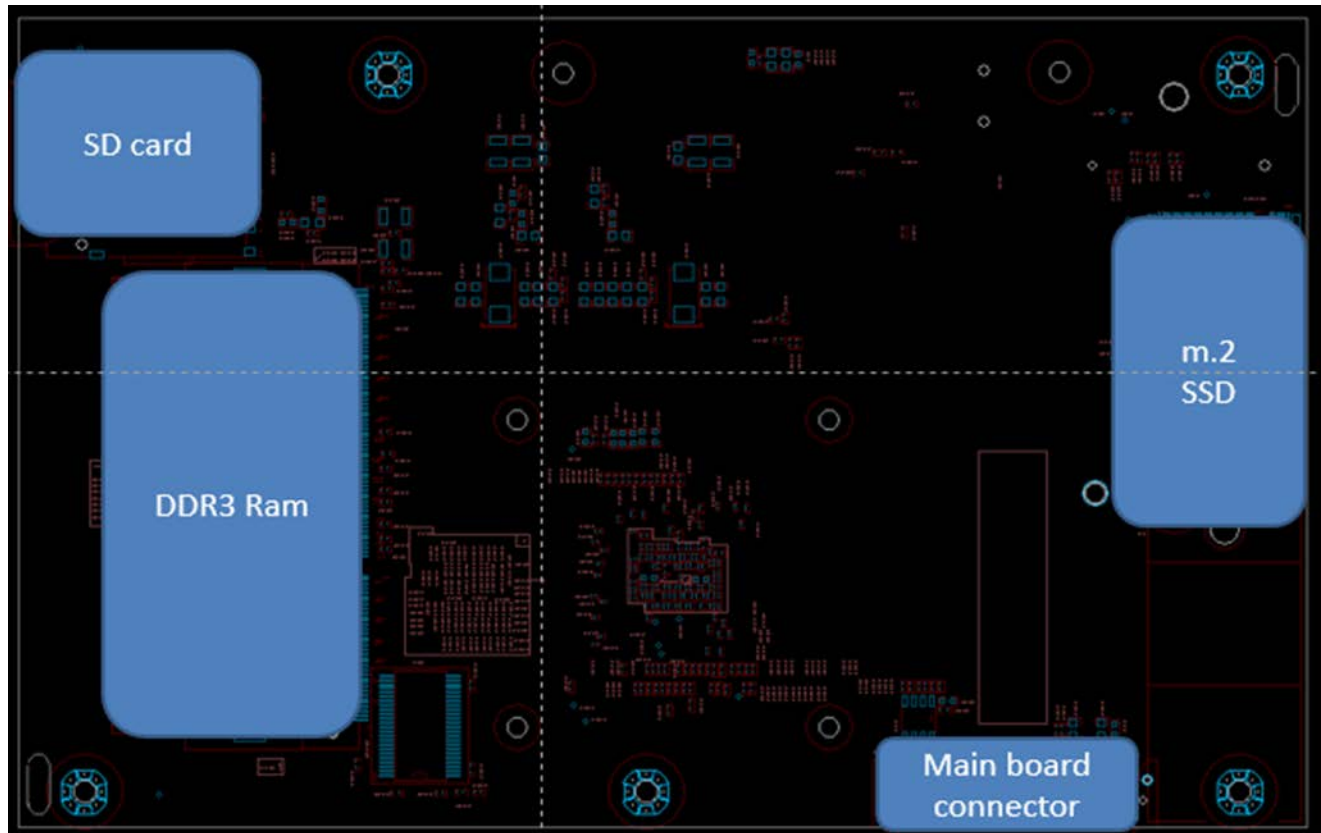

CPU PCB Dimensions

	Inches	Millimeters
Length	5.98	151.9
Width	4.83	122

CPU PCB major components

Description	Manufacturer	Part Number
CPU	Freescale	T2080NSN7PNC 1.5GHz 1.0V FCPBGA780 FREESCALE
CPU	FREESCALE	T2080NSN8TTB
SDRAM (8GB per channel)	UNIGEN	UG10U7211P8UU-BDE
USB to NAND Flash 8GB	ATP	AF8GSSGH-AC2
NOR Flash (128MB)	MICRON	JS28F00AM29EWHA
Trusted Platform Module (TPM)	ST	ST33ZP24AR28PVSK
mSATA Connector	TE	1775838-2
M.2 connector	CONCRAFT	213BAAA32FA
SD Connector	CVILUX	CSD-09A001D
B2B Connector	SAMTEC	BTH-060-01-F-D-RA-WT-K

X86 Rangeley CPU Module PCB

The x86 CPU module is a 12 layer PCB and supports the communication processor and associated components for the CPU subsystem. The communication processor utilized is an Intel Atom C2000 series communication processor. This family of Intel SoCs offers a wide range of pin compatible options scaling from two to eight cores, a thermal design power (TDP) of 7W to 20W, integrated HW acceleration, and Intel Xeon Instruction Set Architecture compatibility.

X86 Rangeley CPU PCB Top and Bottom side

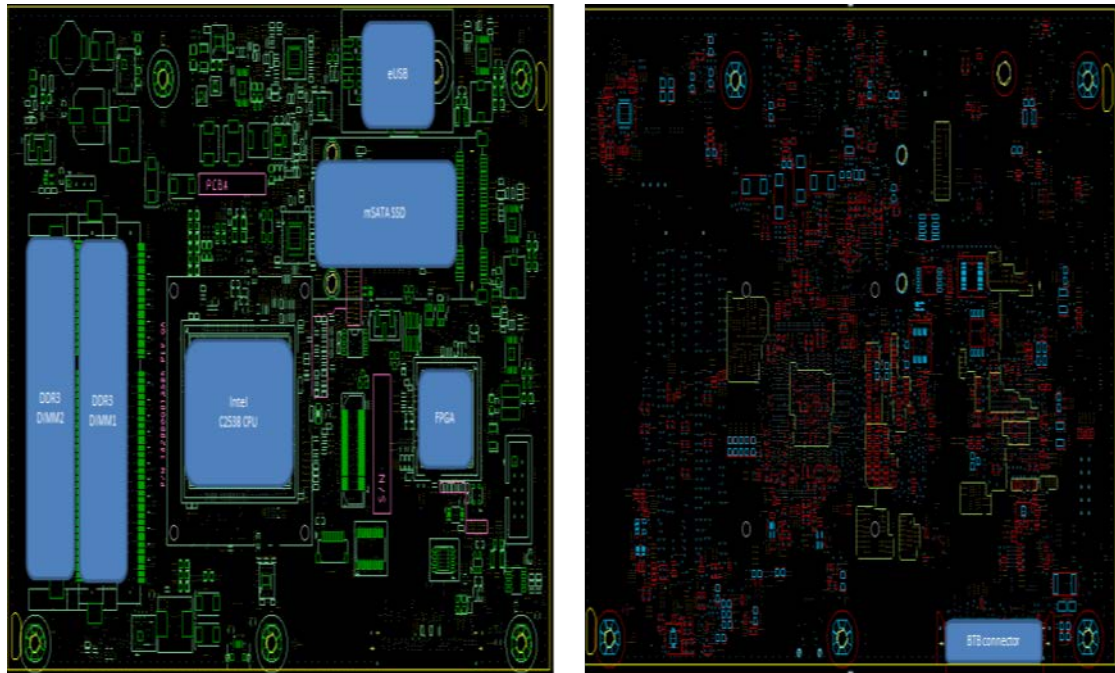

X86 Rangeley CPU PCB Dimensions

	Inches	Millimeters
Length	7.33	186
Width	4.86	123.5

X86 Rangeley CPU PCB major components

Description	Manufacturer	Part Number
CPU	Intel	C2538 – 2.4GHz 3.0V
SDRAM 4GB SO-DIMM w/ECC (x2)	Innodisk	M3D0-4GHS2LPC 4GB 1.35V
USB to NAND Flash 8GB	ATP	AF8GSSGH-AC1
SPI NOR Flash 8MB (x2)	Winbound	W25Q64FVSSIG
Trusted Platform Module (TPM)	STMicroelectronics	ST33ZP24AR28PVSP ST
FPGA	Microsemi	A2F200M3F-FGG256
mSATA Connector	TE Connectivity	1775838-2
B2B Connector	SAMTEC	BTH-060-01-F-D-RA-WT-K

120 Pin CPU PCB to Main PCB Connector

ES7632BT 120 Pin	ES7632BT 120 Pin	General Function	CONNECTOR				General Function	ES7632BT 120 Pin	ES7632BT 120 Pin
			IN/OUT	PIN #	PIN #	IN/OUT			
(D)M75BD_SCLK	IN	TEMP_ANODE	IN/OUT	119	120	OUT	I2C_2_SCL	IN	I2C_1_SCL
(O)M75BD_SDA	IN/OUT	TEMP_CATHODE	IN/OUT	117	118	IN	MGMT_RS232_DCD	IN	CPU_PROCHOT
GND		GND	-	115	116	IN/OUT	GPIO		Not Used
CPU_MPHY_SGMII_TX_0_S_P	OUT	MPHY_SGMII_TX_P	OUT	113	114	IN/OUT	I2C_2_SDA	IN/OUT	I2C_1_SDA
CPU_MPHY_SGMII_TX_0_S_N	OUT	MPHY_SGMII_TX_N	OUT	111	112	IN/OUT	GPIO		Not Used
GND		GND	-	109	110	IN	INTERRUPT		GND
MPHY_CPU_SGMII_RX_0_S_N	IN	MPHY_SGMII_RX_N	IN	107	108	IN	INTERRUPT	OUT	PCIE_OOB_TX_P
MPHY_CPU_SGMII_RX_0_S_P	IN	MPHY_SGMII_RX_P	IN	105	106	OUT	MGMT_RS232_DTR	OUT	PCIE_OOB_TX_N
GND		GND	-	103	104	IN/OUT	PROCHOT#		GND
CPU_MPHY_MDC	OUT	GPIO(MPHY_MDC)	OUT	101	102	IN/OUT	GPIO	IN	PCIE_OOB_RX_P
Not Used		INTERRUPT(MPHY)	IN	99	100	OUT	THRMTRIP#	IN	PCIE_OOB_RX_N
CPU_MPHY_MDIO	IN/OUT	GPIO(MPHY_MDIO)	IN/OUT	97	98	IN	INTERRUPT		GND
GND		GND	-	95	96	IN	MGMT_RS232_RXD	IN	UART1_RX
IP_UART0_SOUT	IN	GPIO	IN/OUT	93	94	IN	MGMT_RS232_CTS	IN	UART1_CTS
CPLD23_INT_CPU	IN		IN	91	92	IN	INTERRUPT	IN	CPU_TDI
1PPS_CPU	IN	GPIO	IN/OUT	89	90	OUT	MGMT_RS232_TXD	OUT	UART1_TX
GND		GND	-	87	88	IN	INTERRUPT	IN	MAC_INT_L
GND		GND	-	85	86	-	GND		GND
CPU_XFI_BC_TX_0P	OUT	DIFF_PAIR_TX_0_P	OUT	83	84	IN/OUT	MGMT_USB_N	IN/OUT	USB2_N
CPU_XFI_BC_TX_0N	OUT	DIFF_PAIR_TX_0_N	OUT	81	82	IN/OUT	MGMT_USB_P	IN/OUT	USB2_P
GND		GND	-	79	80	-	GND		GND
GND		GND	-	77	78	OUT	HWIO	OUT	UCD9090_ALERT_L
CPU_XFI_EC_RX_0P	IN	DIFF_PAIR_RX_0_P	IN	75	76	OUT	MGMT_RS232_RTS	OUT	UART1_RTS
CPU_XFI_EC_RX_0N	IN	DIFF_PAIR_RX_0_N	IN	73	74	OUT	HWIO	OUT	RESET_SYS_CPLD
GND		GND	-	71	72	IN/OUT	GPIO	OUT	CPU_TMS
GND		GND	-	69	70	OUT	JTAG_TRST#	OUT	CPU_JTAG_RST
CPU_XFI_EC_RX_2P	IN	DIFF_PAIR_RX_1_P	IN	67	68	OUT	HWIO	IN	PI014_RST
CPU_XFI_EC_RX_2N	IN	DIFF_PAIR_RX_1_N	IN	65	66	IN/OUT	GPIO	OUT	CPU_TDO
GND		GND	-	63	64	IN/OUT	GPIO	OUT	CPU_TCK
GND		GND	-	61	62	IN/OUT	GPIO	OUT	IP_UART0_SIN
CPU_XFI_EC_TX_2P	OUT	DIFF_PAIR_TX_1_P	OUT	59	60	IN/OUT	I2C_0_SDA		Not Used
CPU_XFI_EC_TX_2N	OUT	DIFF_PAIR_TX_1_N	OUT	57	58	OUT	I2C_0_SCL		Not Used
GND		GND	-	55	56	IN	INTERRUPT	IN	SYS_CPLD_INT_CPU
GND		GND	-	53	54	OUT	HWIO	IN	USB1_PWRFAULT
CPU_PEX_PCIEA_TX_0_P	OUT	PCIE_TX_2_P	OUT	51	52	IN	RESET_MODULE_REQ#	IN	Manu_RST
CPU_PEX_PCIEA_TX_0_N	OUT	PCIE_TX_2_N	OUT	49	50	OUT	I2C_1_SCL	OUT	I2C_0_SCL
GND		GND	-	47	48	IN/OUT	I2C_1_SDA	IN/OUT	I2C_0_SDA
GND		GND	-	45	46	OUT	RESET_SYS_REQ#	OUT	RESET_MAC
CPU_PEX_PCIEA_TX_1_N	OUT	PCIE_TX_3_P	OUT	43	44	IN	SYS_PWR_GOOD	OUT	CPU_THERMALTRIP
CPU_PEX_PCIEA_TX_1_P	OUT	PCIE_TX_3_N	OUT	41	42	OUT	HWIO	OUT	USB1_VBUS
GND		GND	-	39	40	-	GND		GND
GND		GND	-	37	38	-	GND		GND
PEX_CPU_PCIEA_RX_0_N	IN	PCIE_RX_2_P	IN	35	36	OUT	PCIE_TX_0_P	OUT	CPU_PEX_PCIEB_TX_0_P
PEX_CPU_PCIEA_RX_0_P	IN	PCIE_RX_2_N	IN	33	34	OUT	PCIE_TX_0_N	OUT	CPU_PEX_PCIEB_TX_0_N
GND		GND	-	31	32	-	GND		GND
GND		GND	-	29	30	-	GND		GND
PEX_CPU_PCIEA_RX_1_N	IN	PCIE_RX_3_P	IN	27	28	IN	PCIE_RX_0_P	IN	PEX_CPU_PCIEB_RX_0_P
PEX_CPU_PCIEA_RX_1_P	IN	PCIE_RX_3_N	IN	25	26	IN	PCIE_RX_0_N	IN	PEX_CPU_PCIEB_RX_0_N
GND		GND	-	23	24	-	GND		GND
GND		GND	-	21	22	-	GND		GND
CPU_PEX_PCIEB_TX_1_N	OUT	PCIE_TX_1_P	OUT	19	20	IN	PCIE_RX_1_P	IN	PEX_CPU_PCIEB_RX_1_P
CPU_PEX_PCIEB_TX_1_P	OUT	PCIE_TX_1_N	OUT	17	18	IN	PCIE_RX_1_N	IN	PEX_CPU_PCIEB_RX_1_N
GND		GND	-	15	16	-	GND		GND
GND		GND	-	13	14	-	GND		GND
GND		GND	-	11	12	-	GND		GND
VCC12		12VDC	-	9	10	-	12VDC		VCC12
VCC12		12VDC	-	7	8	-	12VDC		VCC12
VCC5P0		5VDC	-	5	6	-	12VDC		VCC12
VCC5P0		5VDC	-	3	4	-	12VDC		VCC12
VCC5P0		5VDC	-	1	2	-	12VDC		VCC12

Thermal Monitoring

The AS5900-54X contains 5 system fans used to cool device. The system is also designed with several temperature sensors to detect temperature at several locations within the system. The system supports three temperature sensors on the main PCB board and one temperature sensor on the CPU board.

Main PCB Thermal sensor locations

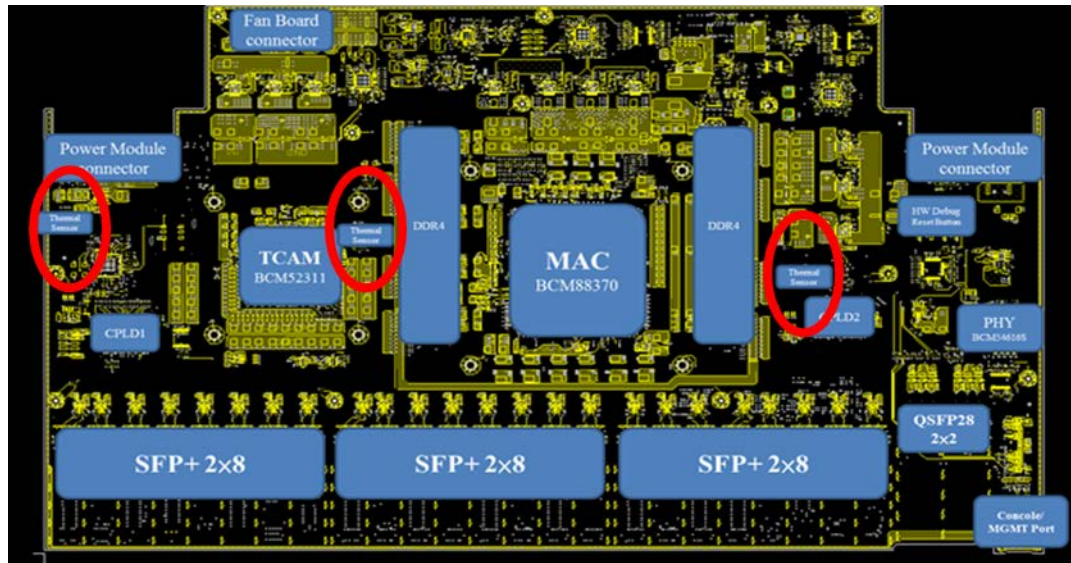

X86 Broadwell-DE CPU Module thermal sensor location

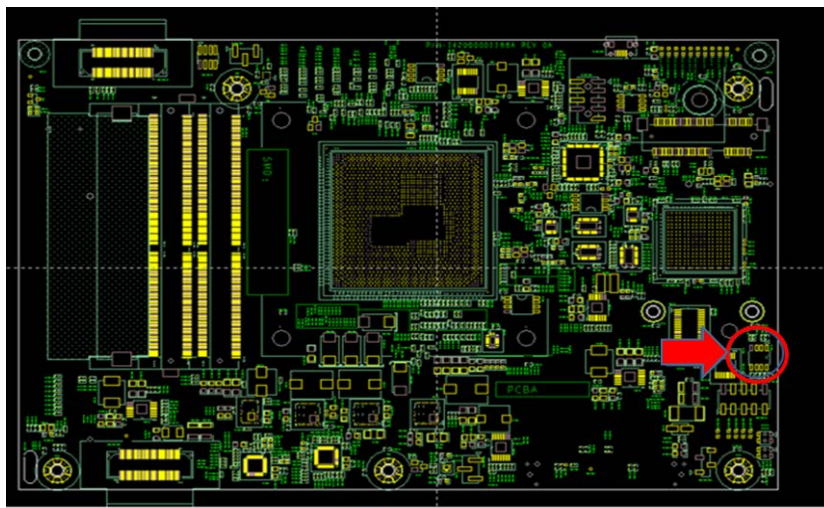

T2080 CPU Module thermal sensor location

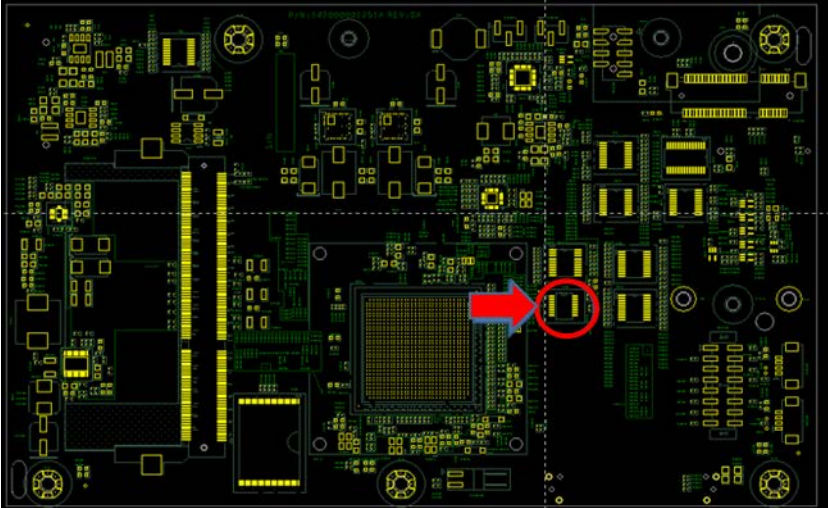

X86 Rangeley CPU Module thermal sensor

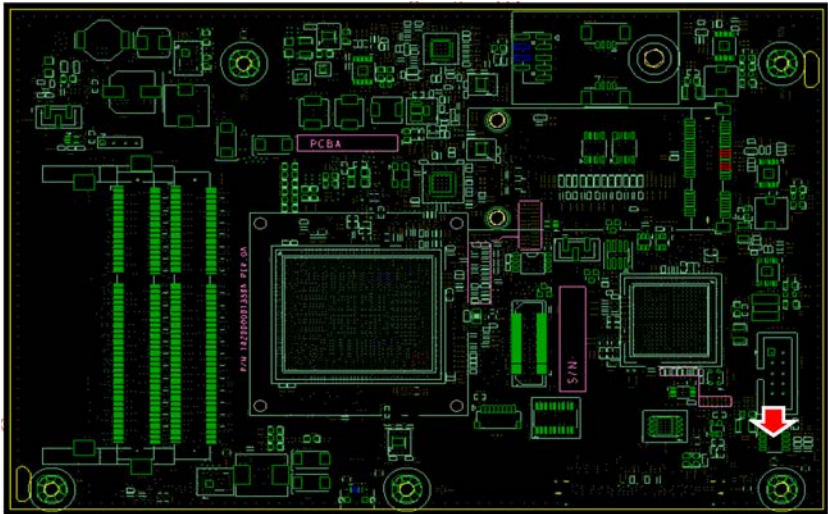

Software Support

The AS5900-54X supports a base software package composed of the following components:

BIOS support

The AS5900-54X Supports AMI AptioV BIOS version A01 or greater with the x86 CPU module

U-Boot

The AS5900-54X Supports U-Boot version 1.4.0.2 or greater with the T2080 CPU module

ONIE

See <http://onie.org/> for the latest supported version

Open Network Linux

See <http://opennetlinux.org/> for latest supported version

Specifications

Power Consumption

The total estimated system power consumption of the AS5900-54X is ~450 Watts. This is based upon worst case power assumptions for traffic, optics used (5W per port), and environmental conditions. Typical power consumption will be less.

Environmental

- Weight 19.56lbs / 8.8kg
- 0 to 40 Degrees C operating range
- -40 to 40 Degrees C storage temperate range
- Humidity 5% to 95% non-condensing (operational and storage)
- Vibration – IEC 68-2-36, IEC 68-2-6
- Shock – IEC 68-2-29
- Acoustic Noise Level – Under 60dB in 40 degree C
- Altitude - 15,000 (4572 meters) tested operational altitude

Safety

- UL/ Canada
- CB (Issued by TUV/RH)
- China CCC

Electromagnetic Compatibility

- CE
- EN55022 Class A
- EN55024
- EN61000-3-2
- EN61000-3-3
- FCC Title 47, Part 15, Subpart B Class A
- VCCI Class A
- CCC

ROHS

Restriction of Hazardous Substances (6/6)

Compliance with Environmental procedure 020499-00 primarily focused on Restriction of Hazardous Substances (ROHS Directive 2002/95/EC) and Waste and Electrical and Electronic Equipment (WEEE